

LOW PRESSURE [0-15 PSE OR 0-30 PSI]

SEQUENCE OF EVENTS

All of our electric steam generators are equipped with an ON/OFF switch. When the generator is turned on, the water inlet solenoid opens and water flows into the chamber. As the water level rises to (A) and (G) probes, the contactors close. Electrical current passes through the contactors to the heaters. At this stage, the heaters are fully immersed in water. The process of heating the water and the accumulation of steam begins. Water will continue entering the chamber until it touches the (C) probe. Steam pressure will build up until reaching a set point (12 or 25 PSI). As steam is used, the pressure will drop 3 to 4 PSI. Next, the heaters will be activated to replace the steam that has been used. During this process, the water level is maintained between the (C) and (B) probes.

Each generator is equipped with two pressure controls: one for actual control and the second for safety, in the event the main pressure controls fail. Each generator is supplied with a glass gauge as a visual aid to assist in monitoring the water level inside the chamber. A safety valve located on top of the generator releases the pressurized steam if it exceeds the safety limit.

ELECTRO-STEAM



GENERATOR CORP.

INSTALLATION - OPERATION - MAINTENANCE INSTRUCTIONS

"LITTLE GIANT" / LB-SERIES - LOW PRESSURE (0-15 PSI/0-30 PSI)

The Electro-Steam Generator design consists essentially of a water tube generator, heated by one or more submerged resistance type electric heating elements. Automatic controls are provided to maintain the pre-set operating pressure and to keep the water supply at the required level. Safety features include automatic low-water cut-off, automatic pressure control, safety valve and visible water level gauge. The entire unit is built in accordance with the A.S.M.E. Miniature Boiler Code and each unit is individually inspected and stamped by an Authorized National Board Insurance Inspector and meets OSHA requirements.

INSTALLATION - NOTE: Ambient temperature around this unit must not exceed 105° F.

Important - Set Unit perfectly level, and as close as possible (within ten feet) to the using equipment. For interpretation of numbered items, refer to Drawing attached.

- A. Water Supply - Purge water supply line before making connection. Connect water source line to the water inlet strainer (#1). Note: Water pressure must not exceed 35 PSI, and must be at least 10 PSI higher than operating pressure. City water quality is usually satisfactory. If treatment is used, purity should not exceed 20,000 ohms .
- B. Steam Outlet (#6) - Connect steam outlet valve on top of Generator to piping from the piece of equipment, vessel, room or area to be operated by the Generator. Insulate all steam lines.
- C. Safety Valve (#10) - If installation of a discharge pipe from safety valve is required, pipe should never be smaller than valve outlet and should be rigidly supported placing no weight on safety valve itself.
- D. Electrical Power: NOTE: Check TIGHTNESS of ALL connections periodically.
 1. Electrical Disconnect - The proper size three-pole disconnect panel should be located close to the Generator for line service connection from the panel to the Generator. The line service requirement is marked on the plate attached to the electric control box on the Generator.
 2. Line Service - The only connection required is from the disconnect panel to the electric panel box on the Generator. It must be the proper size and in accordance with the local electrical codes.
 3. Electric Rating - Voltage-Phase-Kilowatt capacity is stamped on the name plate located on the electric panel box of the Generator.

CAUTION: This unit may have more than one power supply: Disconnect before servicing.

50 INDEL AVENUE • PO BOX 438 • RANCOCAS, NJ 08073-0438 • PHONE: 1-800-634-8177 • FAX: 1-888-783-2624

email: sales@electrosteam.com
www.electrosteam.com

phone: 609-288-9071
fax: 609-288-9078

LOW PRESSURE INSTRUCTIONS - CONTINUED - Page 2

1. Check steam outlet and drain valves (#6 & #7) to insure they are closed.
2. OPEN gauge glass valves (#4) top and bottom.
3. Turn on water supply from the source to the Generator.
4. OPEN steam outlet valve (#6) on top of Generator - slightly - to allow air to escape.
5. Place main power panel switch in ON position.
6. Place Toggle Switch (on electric panel box of Generator) in ON position. Solenoid Valve will open and water in boiler will rise to normal working level.
7. Close steam outlet valve (#6) when pump has stopped.
8. When Generator has reached set working pressure (normally 12 PSI - Low Pressure Models). SLOWLY OPEN the steam outlet valve (#6) taking about 60-90 SECONDS to do so. WHEN FULLY OPEN, leave the valve in that position while in operation. The electric Generator is now in full operation and will perform automatically until you shut it off.

TO SHUT OFF:

Place Toggle Switch (on electric panel box of Generator) in OFF position. Leave steam outlet valve open, allowing pressure to drop normally and Generator to cool down slowly.

CLEANING AND MAINTENANCE

Due to the ABSENCE of an impinging flame on the tubes, scaling in the All Electric Generators is reduced to a minimum. However, the following cleaning procedures are highly recommended in order to keep the Generator in the best operating condition at all times.

1. Normal Water Areas - Blow down at least ONCE A WEEK.
2. Bad Water Areas - Blow down ONCE A DAY.

A. MANUAL "BLOWING DOWN"

1. Place main power panel switch in OFF position.
2. Open drain valve slowly (#7) allowing steam to blow itself into the drain line and clean the chamber. (If the Generator is equipped with an Automatic Flush and Drain System, see the special instructions below).

B. INSTRUCTIONS FOR GENERATORS HAVING AUTOMATIC FLUSH AND DRAIN SYSTEM

Generators equipped with the Automatic Flush and Drain System will be set automatically when the Generator is turned off. When the Toggle Switch (on top of the Unit) is turned ON, the Automatic Flush and Drain Timer goes into operation: - opening the Solenoid Valve on the chamber drain line for approximately 3 minutes: - the pump is automatically on during this period and provides pressure for flushing and cleaning the chamber throughout the 3-minute period. At the end of 3 minutes, a timer closes the Solenoid Valve and activates the heater circuit to start the Generator heating to its working pressure. The Automatic Flush and Drain System eliminates normal blow down or cleaning but an alternative manual drain valve has been provided to permit drainage or a manual blow down if desired.

AUTOMATIC FLUSH AND DRAIN SYSTEMS CONTINUED

IMPORTANT – The Generator must be turned OFF at the Toggle Switch mounted on the Generator not at the main electric panel box in the building. If this is not done, the Automatic Flush and Drain System WILL NOT WORK. If it is necessary to also turn the building power off from the main panel box to the Generator, be sure that the toggle switch on the Generator has been turned off AT LEAST 3 MINUTES before the main panel is turned off. If this is not done, the timer in the Automatic Flush and Drain System will not reset itself for the next cycle.

FOR COMPLETE CLEANING OF CHAMBER, FOLLOW THE SPECIAL INSTRUCTIONS ON THE SEPARATE SHEET ATTACHED TO THESE INSTRUCTIONS.

C. GAUGE GLASSES:

1. **CLEANING** – The gauge glass should be clean periodically. This can be done by closing the top and bottom gauge valves and loosening the hexagonal plug in the bottom of the valve allowing water to run out until the gauge glass is clear. This can be done while the boiler is in operation.
2. **CHANGING** – To change a gauge glass, close the valve and open the hexagonal plug. When the gauge is clear of water, loosen the gland nuts at the top and bottom of the gauge glass and remove the old glass. Place the gland nuts, brass washers and rubber glands on the gauge glass in that order on each end of the new glass and replace in the gauge glass valves. Tighten the gland nuts carefully and evenly until snug. Do not over-tighten.

D. SERVICE HINTS:

1. **IF BOILER DOES NOT FILL WITH WATER**
 - a. Check that the valve from the water source to the Generator is ON.
 - b. Check strainer located in the back of the solenoid valve for possible clogging.
 - c. If pressure reducer is installed -- check the setting to insure the unit is adjusted properly.
2. **IF BOILER OVER FILLS**
 - a. The solenoid valve seat could be obstructed and should be cleaned. Clean with a toothpick or wooden match. Do not score surfaces. Use care in applying wrenches so as not to damage the metal parts.
 - b. The water level control rod in the water level control unit could be loose or completely out of the unit or the relay in the water level box could be stuck or damaged.



THE ELECTRO-STEAM GENERATOR CORP.

1000 BERNARD STREET • ALEXANDRIA, VIRGINIA 22314-1299

PHONE:(703)549-0664 • FAX:(703)836-2581 • 1-800-634-8177

ELECTRO-STEAM SPACE-SAVER MODEL

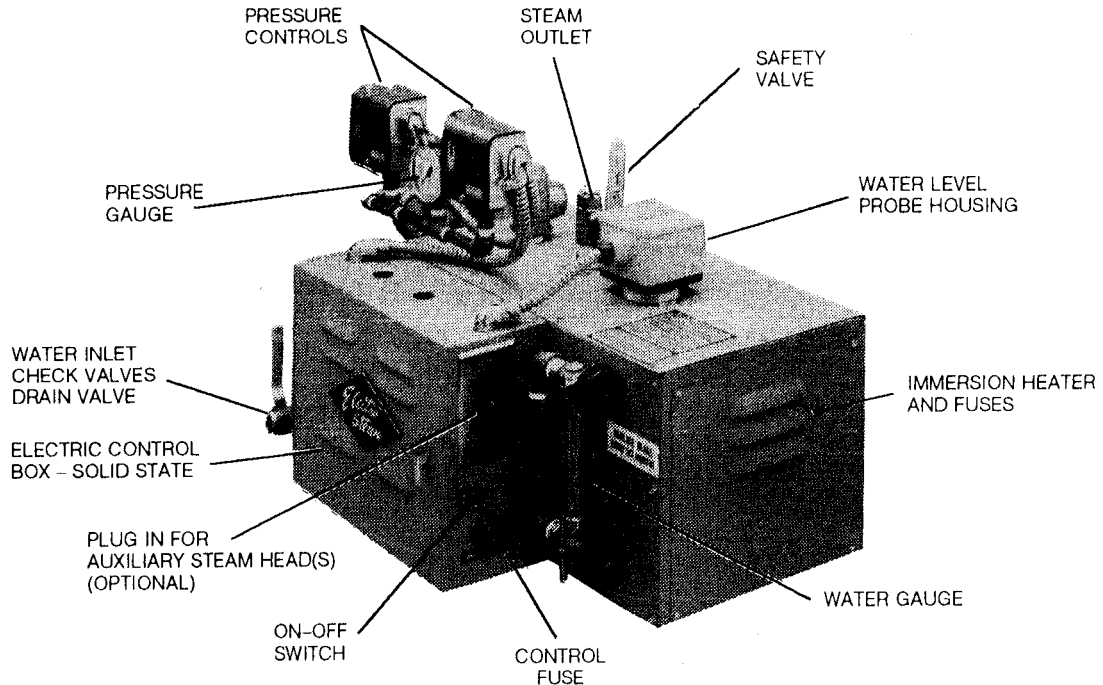

SPACE SAVER MODEL LG10

GENERAL DESCRIPTION—The Electro-Steam generator is a factory assembled and wired unit complete with all necessary automatic controls. Each unit is constructed under the A.S.M.E. Boiler and Pressure Vessel Code-Section 1-Part PMB (Miniature Boilers). Each generator is inspected by an authorized insurance company boiler inspector-holding a National Board commission-and is stamped with a National Board number. Every unit is ETL, CSA and UL approved and meets OSHA requirements. Each generator is composed of one section with a steam space in the upper part. Heat source is all electric removable incoloy immersion heaters inserted horizontally. All generators are completely jacketed in aluminium-backed fiberglass blanket insulation and encased in a 20 gauge sheet metal cabinet finished in baked enamel. Due to the absence of an impinging flame on the tube and expansion and contraction of the electric heater rod-sheath (due to frequent on-off operation) scaling action normally encountered in combustion type boilers is minimized.

HEATING ELEMENT CONSTRUCTION—Nicrome 80-20% wire rod with compacted magnesium oxide, sheathed in an incoloy (stainless) tube. Entire element is silver brazed into a removable 2" flange fitting.

EQUIPMENT—Standard equipment consists of steam pressure gauge, A.S.M.E. approved safety valve, steam outlet valve, blow down valve, two (2) water feed line check valves, water gauge with glass and guard rods, complete controls (see below) and all interconnecting pipe and fittings fully mounted and connected at the factory.

CONTROLS

Low Pressure Package (0-15 and 0-30 lbs PSI)— Included are dual pressure controls, water level control and low water cut off. The steam pressure control is adjustable for desired working pressures and a magnetic stop valve with a strainer is installed on the water feed line.

High Pressure Package (0-100 lbs PSI)— Included are dual high pressure pump controls, water level control and low water cut off. The steam pressure control is adjustable for desired working pressure. A direct motor driven pump is equipped with thermal overload protection and a magnetic stop valve with a strainer is installed on the water feed line.

Electric Controls—All above controls are wired at the factory to an integral control box, operated by a single ON-OFF pilot switch, complete and ready for electrical line service at point of installation.

SPECIFICATIONS

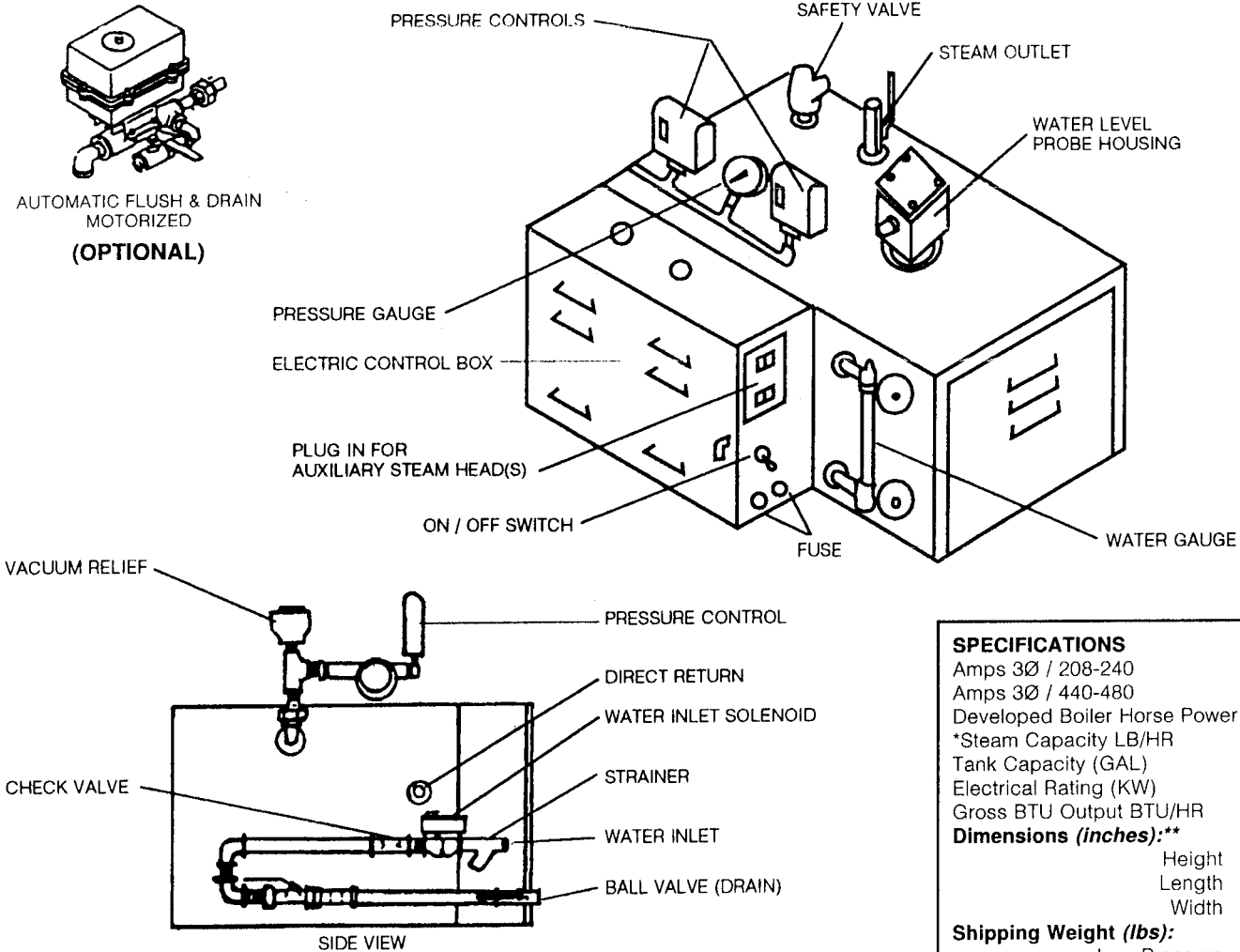

SPECIFICATIONS	
Amps 3Ø / 208-240	28
Amps 3Ø / 440-480	14
Developed Boiler Horse Power	1
*Steam Capacity LB/HR	34.5
Tank Capacity (GAL)	2
Electrical Rating (KW)	10
Gross BTU Output BTU/HR	33,500
Dimensions (inches):**	
Height	23
Length	16
Width	16
Shipping Weight (lbs):	
Low Pressure	125
High Pressure	200

We reserve right to make changes without prior notification

OPTIONAL STEAM HEAD & FOOT CONTROL

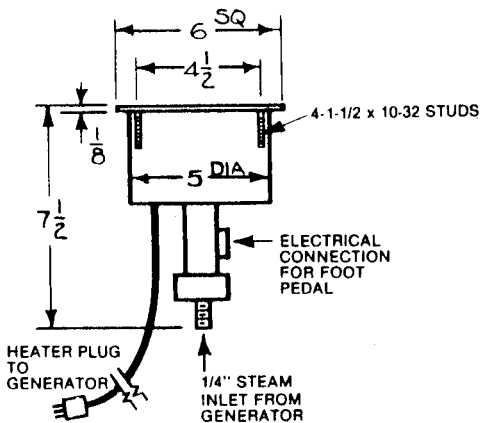

STEAM HEAD

COUNTER TOP PLATE: 6"x 6" x 1/8" STAINLESS STEEL, 2 B FINISH
 BASE DIAMETER: 5 1/4" DIA. OPENING IN COUNTER TOP
 STEAM PORTS: 9 - .093" DIA. STANDARD LAYOUT
 COUNTER TOP FASTENING: 4 STUDS, 1 1/2" x 10 - 22

STEAM LINE CONNECTION:

5° FALL RECOMMENDED. AVOID 90° ELBOWS. USE 1/4" COPPER TUBE, INSULATED, WITH COMPRESSION FITTINGS.

ACTIVATOR FOR STEAM HEAD

FOOT PEDAL & SWITCH FURNISHED AS STANDARD EQUIPMENT. KNEE CONTROL OR AUTOMATIC TIMER ARE OPTIONAL.

*From and at 212°F denotes steam output with 212°F feedwater. Lower temperatures reduce steam output accordingly. We do not recommend feedwater temperature above 140°F unless special hot water pump is provided. Contact our office with any questions.

**Note No. 1 - Unit requires an additional 12" of floor space (width) for ideal plumbing connections and service.

**Note No. 2 - Unit requires an additional 12" clearance at each end for opening of electric panel boxes and servicing of electric heater.



ELECTRO-STEAM GENERATOR CORPORATION



1. WATER INLET STRAINER
2. ON-OFF SWITCH
3. WATER LEVEL CONTROL
4. WATER GAGE GLASS
5. 3/8" WATER INLET SOLENOID
6. STEAM OUTLET 1/2"
7. DRAIN VALVE 3/4"
8. PRESSURE CONTROLS
9. 1/2" VACUUM RELIEF
10. SAFETY VALVE 3/4"
11. STEAM GAGE
12. 11 AMP FUSE
13. PRESSURE CONTROL SAFETY AND 5 P.S.I. PRESSURE CONTROL
14. AUTOMATIC FLUSH & DRAIN (OPTIONAL)
15. CHECK VALVES
16. HEATER COVER
17. ACCESSORY POWER W/ 8 AMP FUSE
18. MOTOR (HIGH PRESSURE UNIT ONLY)

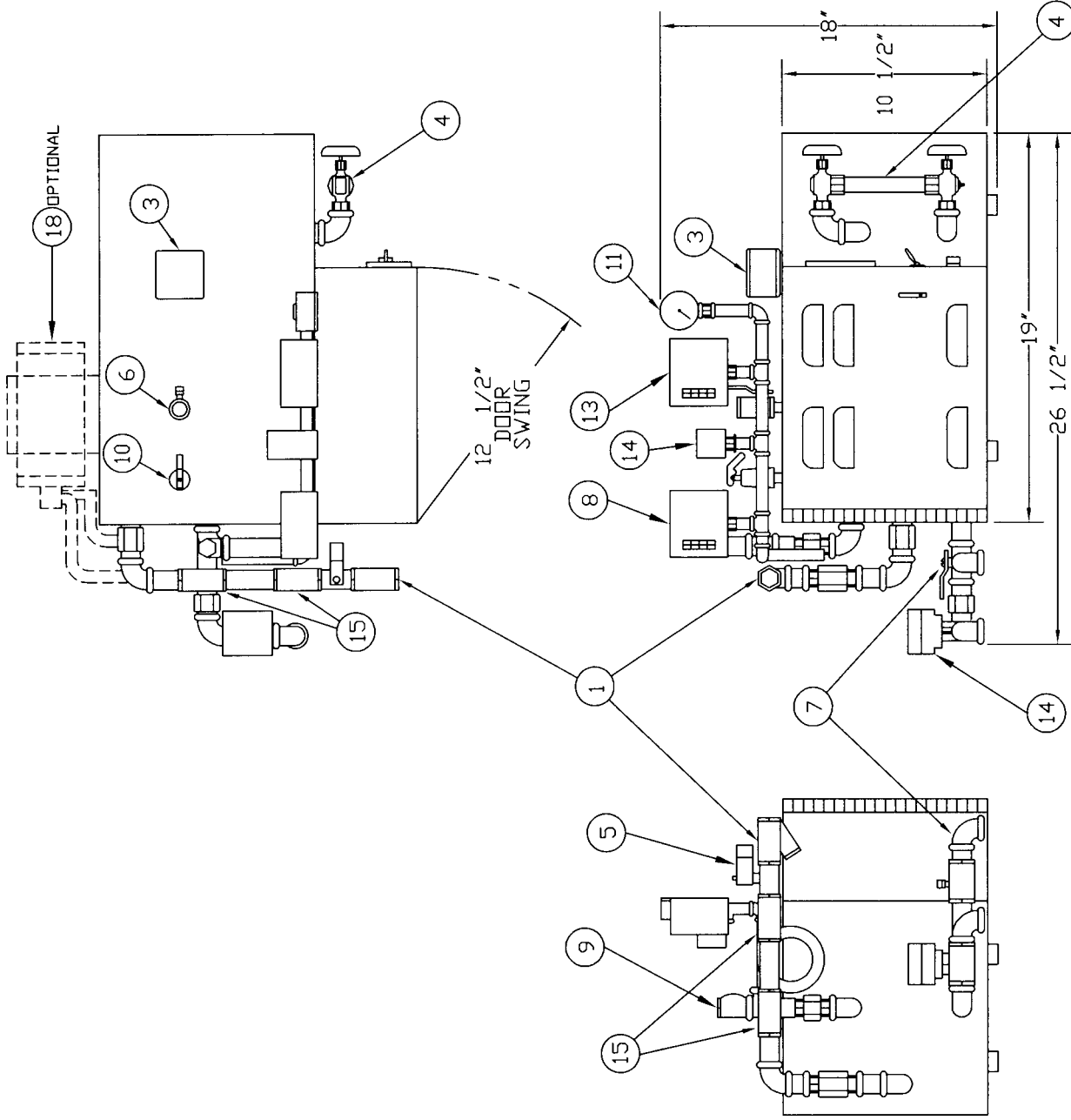

DATE	REVISIONS	DRAWN BY	DATE
	DESCRIPTION	STEPHEN J	
	CHECKED		
	ENGINEER		
	APPROVED	RALPH ASPLING	

ELECTRO-STEAM GENERATOR CORP.	
1000 Bernard Street, Alexandria, Virginia 22314-1299	
DRAWING TITLE	
INSTALLATION DATA	
LB-5-10 SPACE SAVER	
SIZE	AUTOCAD R14 FILE DWG. NO.
50065	PRI-6510-A
REV.	

SERVICE PROCEDURE --- FUSE FAILURE

When a fuse blows, one of the following conditions would be the cause:

A SHORT CIRCUIT HAS OCCURRED: If a short circuit blew the fuse, make sure the line has been cleared, the cause of short circuit removed, then install new fuse.

POOR CONTACT EXISTS: Poor contact on the fuse, near the fuse or in the fuse causes useless blowing of fuses and very often causes destruction of the contact points.

Very often, if poor contact exists, the fuse will indicate it. For example –if the surface that makes contact in the fuse clips is discolored, the fuse has been making poor contact in the clips. If the contact has been tight, very little, if any, air can get to the portions that are making contact, and the contact surfaces will remain bright and clean. If only one end of the fuse has the contact surface badly oxidized, you have a positive indication that poor contact exists at the end where the discoloration has occurred. Installing a larger fuse will not help a particle. The poor contact must be eliminated.

A fuse holder is a contact making device. Damaged clips may hold a fuse but holding the fuse is not enough. It must have a good contact. The clips should make tight contact and they should make contact over a large area. If spring clips are out of shape, they will not make sufficient contact.

WHEN REPLACING FUSE:

1. Do not insert the fuse on live circuits. You would cause an arc that would throw up a burr on the fuse cap which would prevent good contact in the clips.
2. If the insides of clips are not bright and clean, brighten them with emery cloth.
3. If the fuse caps are not bright and clean, brighten them with emery cloth.
4. If the fuse can be easily inserted into spring clips or can be easily rotated after it is inserted, you do not have sufficient contact pressure. Take the fuse out and draw the clips together.
5. If spring clips have lost their spring, they should be replaced or clip clamps should be used.
No. 1 for 0-30 Amps – 250 Volt clips. No. 2 for 35-60 amps – 250 Volt Clips.

Even if clamps are used, be sure that insides of clips are bright and clean.

MOTORIZED AUTOMATIC FLUSH & DRAIN SYSTEM (MAFD)

COMPONENTS:

Components are:

- (1) Flush Valve
- (2) Time Capsule
- (3) Relay with Base
- (4) Pressure Control

OPERATIONS:

At the end of the normal work day when the ON/OFF Switch is placed in the OFF position, the Flush Timer resets itself to prepare for the next flush cycle. (Note: This will happen whenever the power to the control circuits is turned off without regard to the method used-i.e. On/Off Switch, Timer, etc.)

1. Control power turned off – time capsule reset.
2. Control power turned on.
 - a. Time capsule has 3 minutes delay.
 - b. MAFD powered through normally closed side of relay.
 - c. Heater contactor powered through normally open side of relay so contactor is locked out.
3. Time capsule times out after 3 minutes.
 - a. Relay is energized.
 - b. MAFD solenoid is de-energized.
 - c. Heater contactor is enabled.
 - d. Machine proceeds to normal operation.
4. Water level control is independent of MAFD circuits and will attempt to maintain proper water level. Water goes below water cut-off probe "A", push low water reset button. If water input pressure is high enough to maintain a high water level, you will not have to reset at this time.

IMPORTANT:

While the MAFD System eliminates normal blow-down, there is a manual valve provided to permit drainage or a manual blow-down if desired.

This automatic system will extend time between cleanings to approximately or in extremely hard water areas to 3 or 4 times a year.

*Safety Feature: The pressure control is designed to prevent the generator from flushing until the pressure reaches 5 lbs or less.

TO WHOM IT MAY CONCERN

CHAMBER CLEANING SHOULD BE ACCOMPLISHED EVERY 1-3 MONTHS DEPENDING ON WATER QUALITY, EVEN WITH THE MOTORIZED AUTOMATIC FLUSH AND DRAIN. A REGULAR MAINTENANCE PLAN SHOULD BE ESTABLISHED FOR PERIODIC CLEANING. (SEE ATTACHED "CHAMBER CLEANING")

THE MOTORIZED AUTOMATIC FLUSH AND DRAIN IS A DEVICE SET-UP TO "HELP" KEEP THE GENERATOR FLUSHED OUT. IT IS NOT A "CURE ALL." THE GENERATOR WILL EVENTUALLY CLOG UP DOING DAMAGE TO INTERNAL PARTS, IF NOT CLEANED OUT ON A PERIODIC BASIS.

FACTORY SERVICE BULLETIN

Model LG or LB – Chamber Cleaning

IMPORTANT – All Electric Steam Units should be “cleaned” in the following manner twice a year and in “bad water areas” 3-4 times.

1. During periodic cleaning, heater should be removed, cleaned with a wire brush and reinstalled using a new gasket.
2. Water level probes should be removed and cleaned with a scraper or sandpaper and reinstalled assuring that proper wiring is accomplished.
3. Remove and replace sight glass and washers.

WHEN INSTALLING NEW HEATER – You must completely clean both chamber water level sensing probes of the water control before installing new heater or you may have “another heater failure” within 48 hours.

1. “Blow Down” Steam Generator with 10 lbs. steam pressure on gauge.
2. Start Generator – and when gauge glass shows ½ full, shut off Generator.
3. Remove Safety Valve.
4. Insert Funnel in safety valve outlet (or outlets).
- 5.* Pour hydrochloric acid (inhibited) solution (NON-FOOD APPLICATIONS) into funnel very slowly – being careful of fumes and venting while pouring. (Solution can be obtained from any industrial chemical dealer.)

*NOTE: For Food Steaming applications use FDA approved chemicals.

*NOTE: For Stainless Steel Chambers use Sulfamic Acid.

6. Amount of Solution – Use ½ gallon on single heater models. Use 1 gallon on 2 heater models up.
7. Reinstall Safety Valve.
8. Close steam outlet valve and let solution set in Generator for 1 hour. Turn Generator on until 5 lbs. steam pressure shows on pressure gauge. Then shut off Generator. When steam pressure drops to zero, open steam outlet valve and fill Generator with water and let stand for ½ hour.
9. Open blow down (drain) valve and drain Generator.
10. Close blow down (or drain) valve and open steam outlet valve. Fill Generator again with clean water. Then open blow down (or drain) valve again and drain Generator.
11. Repeat operation in #9 and #10 to flush out Generator completely.
12. Start Generator – and when 10 lbs. pressure shows on steam gauge, shut off Generator and open blow down (or drain) valve for approximately 5-10 minutes. Then close blow down (or drain) valve.
13. Electric Steam Unit is now ready for normal use and operation.

(SEE OVER)

IMPORTANT

SPECIAL CLEANOUT PROCEDURE FOR UNITS WITH AUTOMATIC FLUSH ACCESSORY

1. Start Generator in normal manner in order to flush out loose sediment.
2. After flushing - when water in sight glass begins to rise – turn off switch.
3. Make sure unit is cooled. Remove Steam Pressure Relief Valve.
4. Pour in a half gallon of the F.D.A. approved cleaning solution.
5. Replace the Steam Pressure Safety Valve.
6. Remove the IDEC Relay from its base (located in the top of the Electrical Control Box).
7. Turn on unit for 30 minutes.
8. Turn off power and replace IDEC Relay.
9. Turn unit on and off to initiate Flush and Drain Cycle two (2) more times.
10. Generator is now prepared for normal operation.

Electro-Steam Generator Corporation Terms and Conditions of Sale

These terms and conditions apply to all goods or services Seller provides. Seller recognizes no other terms and conditions unless approved in writing by Seller's authorized representative. Seller rejects any additional terms and conditions that may be contained in any document provided previously or subsequently by your company.

CHANGES: Changes made after fabrication has begun shall be submitted in writing, signed by the purchaser. Purchaser agrees to pay the cost of any changes. The specifications and prices are subject to change without notice.

CLAIMS: Title passes to the buyer upon delivery to the carrier, unless otherwise indicated. Safe delivery is the responsibility of the carrier. Damaged merchandise, if accepted, should be noted on the delivery receipt and on the freight bill before acceptance of shipment. Make claim promptly.

CONTINGENCY: All contracts are contingent upon fire, strikes, accidents, delays in transit, acts of God or other causes beyond our control.

LOCAL CODES: ELECTRO-STEAM GENERATOR CORPORATION DOES NOT ASSUME RESPONSIBILITY OR COST OF FIELD CHANGES TO ITS PRODUCTS TO MEET LOCAL OR STATE CODES. WE WILL BE GLAD TO QUOTE ANY REQUESTED REQUIREMENTS.

FREIGHT TERMS: F.O.B. FACTORY, NO FREIGHT ALLOWED. All charges for unloading and transportation to job site are at the buyer's expense.

INSTALLATION: No installation or job supervision charges are included.

ORDERS: All orders resulting from this quotation are subject to acceptance by the factory. No production will begin until receipt of purchaser's signed order and credit approval.

PAYMENT TERMS: Within Continental U.S.A., net 30 days, with approved credit from the date of invoice (not date of arrival of goods). Payment in full without retainer and/or any unauthorized sums deducted is expected.

RETURNS OF MATERIAL: No goods will be accepted for return without a return authorization number from the factory. A 25% restocking fee is charged on returns, freight prepaid.

TAXES: No taxes of any kind are included. All prices herein and/or contracts shall be subject to increase without notice by the amount of present or future sales or excise tax levied or charged, either by Federal, State or any other assessing agency.

PATENT INDEMNITY:

In the event of a claim against the purchaser which charges that the equipment from Electro-Steam Generator Corporation infringes a U.S. patent subsisting when the equipment was shipped, Electro-Steam Generator Corporation shall, at its sole option, procure for the purchaser the right to use the equipment; or replace the equipment with non-infringing equipment; or modify the equipment to be non-infringing; or remove the equipment and refund the purchase price, less depreciation at the rate of fifteen percent (15%) per year or defend, at its own expense, all suits instituted against the Purchaser insofar as same are based upon any claim that the purchaser's operation of the equipment, or any part thereof, is an infringement of a U.S. patent under the proviso that: (a) Electro-Steam Generator Corporation be notified, in writing, by purchaser promptly upon assertion of claim; (b) Electro-Steam Generator Corporation be given authority by Purchaser to assume full and exclusive control of the defense and settlement of the claim or suit; and (c) purchaser provides all information and assistance to Electro-Steam Corporation, at purchaser's expense, as is reasonably necessary for the defense of the claim or suit. Electro-Steam Generator Corporation may, at its option, intervene in any suit or action brought against the purchaser on such claim.

THE FOREGOING STATES ELECTRO-STEAM GENERATOR CORPORATION ENTIRE LIABILITY FOR CLAIMS OR PATENT INFRINGEMENT. Electro-Steam Generator Corporation shall have no liability whatsoever if the claim of infringement arises out of Electro-Steam Generator Corporation's compliance with purchaser's specifications. Electro-Steam Generator Corporation shall have no liability whatsoever if a claim of infringement is based upon the purchaser's use of the equipment as part of a patented combination where other elements of the combination are not supplied by Electro-Steam Generator Corporation, or in the practice of a patented process.

ELECTRO-STEAM GENERATOR CORPORATION LIMITED WARRANTY:

Electro-Steam Generator Corporation fully warrants that all equipment and service supplied shall conform to the description in the quotation and agrees to repair or replace F.O.B. shipping points any parts, excepting expendable items, that fail due to defects in material or workmanship. The pressure vessel; (steam chamber) are warranted to the original Purchaser for a period of five years from the date of shipment from our factory. Mechanical and electrical components, along with accessories and hoses, are warranted for a period of one (1) year from date of shipment from our factory. IN NO EVENT SHALL ELECTRO-STEAM GENERATOR CORPORATION'S WARRANTY BE EXTENDED BEYOND THE WARRANTY LIABILITY PROVIDED BY THE SUPPLIER OR MANUFACTURER OF COMPONENT PARTS INCORPORATED IN THIS EQUIPMENT. THERE ARE NO OTHER WARRANTIES OF ANY KIND, EXPRESSED OR IMPLIED, AND SPECIFICALLY EXCLUDED BUT NO BY WAY OF LIMITATION ARE THE IMPLIED WARRANTIES OF FITNESS FOR PARTICULAR PURPOSE AND MERCHANTABILITY.

All claims for incorrect products or replacement must be made and settled prior to installation. Electro-Steam Generator Corporation assumes no liability for the expense of repairs made outside its factory. Any claims for labor and/or parts will be denied unless written authorization is given by Electro-Steam Generator Corporation prior to work being done.

IT IS UNDERSTOOD AND AGREED THAT ELECTRO-STEAM GENERATOR CORPORATION'S LIABILITY, WHETHER IN CONTRACT, IN TORT, UNDER ANY WARRANTY, IN NEGLIGENCE OR OTHERWISE, SHALL NOT EXCEED THE COST OF REPAIR OR REPLACEMENT, F.O.B. SHIPPING POINTS OF DEFECTIVE PARTS. UNDER NO CIRCUMSTANCES SHALL ELECTRO-STEAM GENERATOR CORPORATION BE LIABLE FOR SPECIAL, INDIRECT, INCIDENTAL, OR CONSEQUENTIAL DAMAGES. THE PRICE STATED FOR THE EQUIPMENT IS A CONSIDERATION IN LIMITING ELECTRO-STEAM GENERATOR CORPORATION'S LIABILITY. NO ACTION, REGARDLESS OF FORM, ARISING OUT OF THE TRANSACTIONS OF THIS AGREEMENT MAY BE BROUGHT BY PURCHASER MORE THAN ONE YEAR AFTER THE CAUSE OF ACTION HAS ACCRUED. THE WARRANTY FOR THIS EQUIPMENT OR SERVICE PROPOSED IN THIS QUOTATION IS AS STATED IN THE AFOREMENTIONED PARAGRAPHS. IT IS NOT RESTATED NOR DOES IT APPEAR IN ANY OTHER FORM.

This warranty supersedes all prior verbal or written warranties.

INSURANCE: Buyer represents that they have a program of Insurance which adequately protects their interest, and that of their employees and agents, including damage to plant, property and equipment, personal injury of any kind, directly or indirectly related in any way to the equipment, service, repair or parts supplied by Seller. Accordingly, Buyer waives any claim against Seller for the foregoing, and on behalf of its Insurance Company, any right of subrogation in connection therewith.

LAW: This Agreement shall be governed by the internal laws of the State of New Jersey, USA, and any disputes arising under these Terms & Conditions shall be resolved in the state or federal courts in Camden, New Jersey for the U.S. District Court or Burlington County for the state courts in the State of New Jersey.

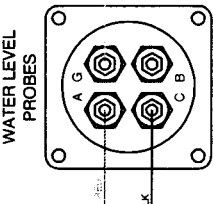
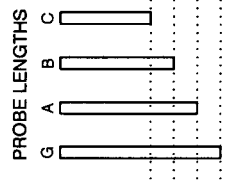
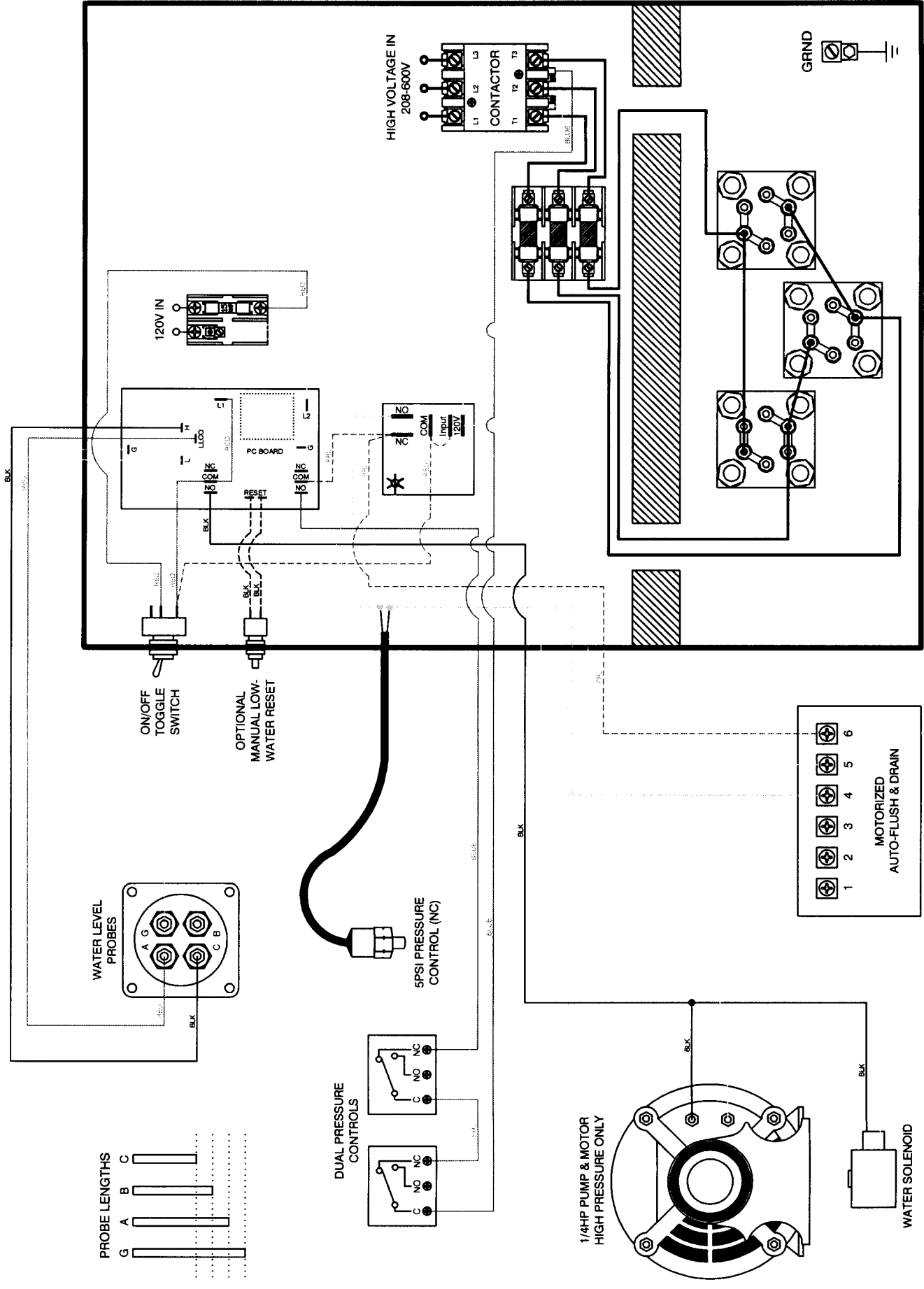

ON/OFF TOGGLE SWITCH

OPTIONAL MANUAL LOW-WATER RESET

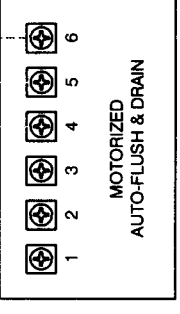
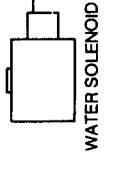
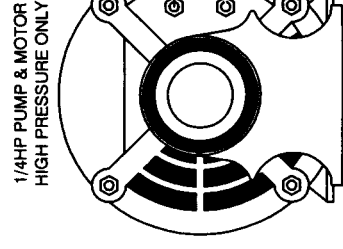
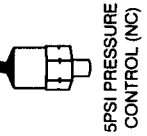
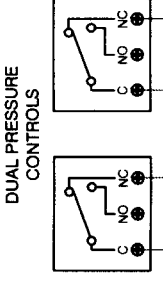

DRAWING TITLE: LG (H) (MAFD)		MODEL UNIT: LG 10-30
DESCRIPTIONS:	DRAWN BY: CHRISTOPHER FERRARA	03-26-07
HIGH PRESSURE	CHECKED: SAL NEGRO	03-26-07
MOTORIZED AUTO-FLUSH & DRAIN	ENGINEER: CHRISTOPHER FERRARA	03-26-07
APPROVED:		DWG NO.: 2121110-010-030
ELECTRO-STEAM GENERATOR CORP.		SCALE: N/A
50 Indel Ave. P.O. Rancocas, NJ 08073-0436		SHEET: 1 OF 1

This drawing and all information therein are the property of Electro-Steam Generator Corp. and shall not be disclosed, in whole or in part, to any third party without prior permission of Electro-Steam Generator Corp.

(3PH) 8.3KW - (208-240V)

- (1) CONTACTOR: 40AMP-FLA, 50AMP-RES.
- (1) FUSE BLOCK: 30AMP, 250V, CLS-R.
- (3) FUSES: 30AMP, 250V, CLS-RK5.
- (1) HEATER: 8.33KW, 214 or 240V.

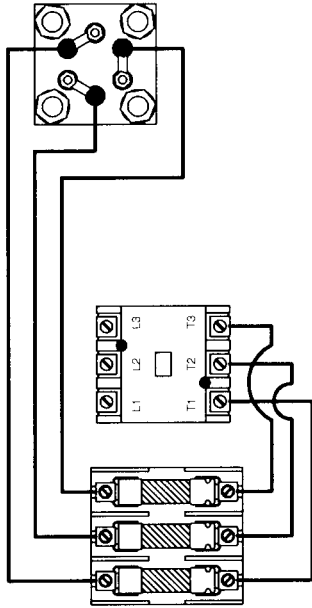

(3PH) 10-13.3KW - (208-240V)

- (1) CONTACTOR: 60AMP-FLA, 75AMP-RES.
- (1) FUSE BLOCK: 60AMP, 600V, CLS-CC
- (3PH) 10KW - (208-240V)
- (3) FUSES: 35AMP, 600V, CLS-CC.
- (1) HEATER: 9.75KW, 208 or 240V

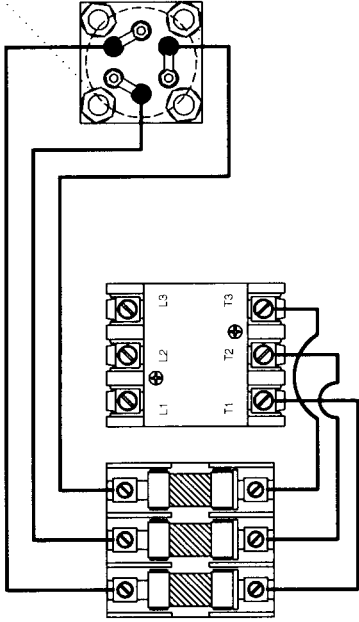

HEATER COILS MUST BE IN THIS POSITION.

- (3PH) 13.3KW - (208-240V)
- (3) FUSES: 50AMP, 600V, CLS-CC.
- (1) HEATER: 13.33KW, 214V

(3PH) 8.3-13.3KW - (380-425V)

- (1) CONTACTOR: 40AMP-FLA, 50AMP-RES.
- (1) FUSE BLOCK: 30AMP, 600V, CLS-CC

- (3PH) 8.3KW - (380-400V)
- (3) FUSES: 17.5AMP, 600V, CLS-CC.
- (1) HEATER: 8.33KW, 214V
- *restamped 380 or 400V*

- (3PH) 10KW - (415-425V)
- (3) FUSES: 17.5AMP, 600V, CLS-CC.
- (1) HEATER: 9.75KW, 240V
- *restamped 415 or 425V*

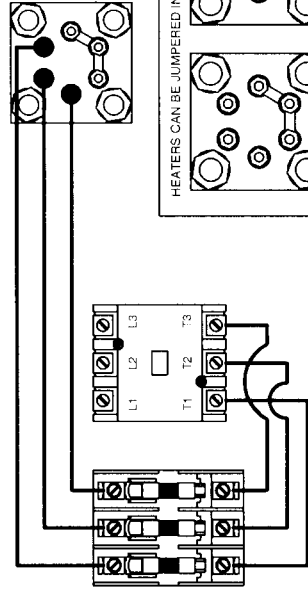

HEATERS CAN BE JUMPERED IN EITHER POSITION

(3PH) 8.3-13.3KW - (550-600V)

- (1) CONTACTOR: 40AMP-FLA, 50AMP-RES.
- (1) FUSE BLOCK: 30AMP, 600V, CLS-CC

- (3PH) 8.3KW - (440-480V)
- (3) FUSES: 12AMP, 600V, CLS-CC.
- (1) HEATER: 8.33KW, 480V

- (3PH) 10KW - (550-600V)
- (3) FUSES: 10AMP, 600V, CLS-CC.
- (1) HEATER: 8.33KW, 600V

- (3PH) 13.3KW - (440-480V)
- (3) FUSES: 20AMP, 600V, CLS-CC.
- (1) HEATER: 13.33KW, 480V

- (3PH) 13.3KW - (550-600V)
- (3) FUSES: 15AMP, 600V, CLS-CC.
- (1) HEATER: 13.33KW, 600V

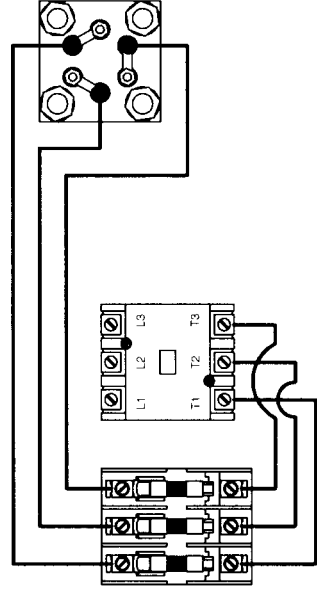

HEATERS CAN BE JUMPERED IN EITHER POSITION

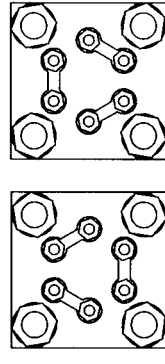

DRAWING TITLE:		MODEL UNIT	SV 8.3-13.3
(HEATERS) SV (3PH)(208-600V)		DESIGNER	CHRISTOPHER FERRARA
THREE PHASE HEATER WIRING		CHECKED	SAL NEGRO
208-600V		ENGINEER	CHRISTOPHER FERRARA
APPROVED		DATE	04-25-07

ELECTRO-STEAM GENERATOR CORP.
 50 Hadel Ave. P. O. Box 6000, N.J. 08073-0439
 SCALE: N.A.
 SHEET 1 OF 1

This drawing and all information therein are the property of Electro-Steam Generator Corp. and shall not be disclosed, in whole or in part, to any third party without prior permission of Electro-Steam Generator Corp.

AMPERAGE REQUIREMENTS FOR HEATER ELEMENTS

<u>3 Phase Voltage</u>	<u>208</u>	<u>220</u>	<u>230</u>	<u>240</u>	<u>277</u>	<u>380</u>	<u>415</u>	<u>440</u>	<u>460</u>	<u>480</u>	<u>550</u>	<u>575</u>	<u>600</u>
LG-10	28	26	25	24	21	15	14	13	13	12	11	10	10
LG-15	42	40	38	36	31	23	21	20	19	18	16	15	15
LG-20	56	53	50	48	42	31	28	26	25	24	21	20	19
LG-25	70	66	63	60	52	38	35	33	31	30	27	25	24
LG-30	84	79	76	72	63	46	42	40	38	36	32	30	29
LB-40	112	105	100	96	84	61	56	53	50	48	42	40	39
LB-50	139	132	126	120	104	76	70	66	63	60	53	50	48
LB-60	167	157	151	145	125	92	84	79	76	72	63	60	58
LB-80	209	197	189	181	157	114	105	99	94	91	79	75	73
LB-100	278	263	251	241	209	152	139	132	126	121	105	100	96
LB-120	334	315	302	289	250	183	167	158	151	145	126	121	116
LB-150	417	394	378	361	313	228	209	197	189	181	158	151	145
LB-180	500	473	453	434	376	274	251	237	227	217	189	181	173
LB-240	668	630	604	578	501	365	334	316	302	290	252	241	231
<u>Single Phase</u>	<u>208</u>	<u>220</u>	<u>230</u>	<u>240</u>	<u>277</u>	<u>380</u>	<u>415</u>	<u>440</u>	<u>460</u>	<u>480</u>	<u>550</u>	<u>575</u>	<u>600</u>
LG-5	24	23	22	21	20	13	12	12	11	11	9	8	8
LG-10	48	46	44	42	40	27	24	23	22	21	18	17	17
LG-15	72	69	65	63	60	40	36	35	33	31	28	26	25
LG-20	96	91	87	84	80	53	48	46	44	42	37	35	34
LG-25	120	114	109	104	100	66	60	57	55	52	46	44	42
LG-30	144	137	131	125	120	79	72	69	66	63	55	53	50