

# REIMERS ELECTRA STEAM, INC.

4407 MARTINSBURG PIKE  
CLEAR BROOK, VA 22624

PHONE:540-662-3811 FAX:540-665-8101 EMAIL: [Sales@reimersinc.com](mailto:Sales@reimersinc.com)

## INSTRUCTION MANUAL JG & JJ MODELS

Serial No.: 56781--60816

### READ THIS FIRST



#### CAUTION:

READ ALL INSTRUCTIONS BEFORE INSTALLATION & OPERATION.  
ENSURE BLOWDOWN PROPERLY AND SAFELY PIPED.  
DO NOT POSITION FACE OR BODY OVER FILL FUNNEL.  
STAND CLEAR OF SAFETY VALVE & SCALDING STEAM.  
NEVER OPEN FILL VALVE WHEN UNIT IS UNDER PRESSURE.

VALVES AND PIPES ARE HOT WHEN UNDER PRESSURE OR HEATING UP. DO NOT TOUCH.

### IF A LEAK IS EVIDENT

STEAM FITTINGS CAN BECOME LOOSE DURING SHIPMENT & SUBSEQUENTLY LEAK. IT IS EASY TO RESOLVE THESE LEAKS IF YOU ARE CAREFUL.

1. ENSURE BOILER IS COLD, DRAINED & HAS NO PRESSURE NOR ELECTRICITY.
2. TIGHTEN LEAKING PACKING NUT GENTLY 1/4TH OF A TURN. **CAUTION:** DO NOT OVERTIGHTEN, AS THIS WILL RESULT IN GAUGE GLASS BREAKAGE OR IN VALVE STEM FREEZING & VALVE FAILURE
3. FILL BOILER & OPERATE NORMALLY.
4. OBSERVE FOR MORE LEAKS & REPEAT STEPS 1 & 2 AS REQUIRED.



#### PACKING NUT LOCATIONS

1. ON EACH VALVE STEM UNDER HANDLE
2. TOP & BOTTOM OF GAUGE GLASS



#### NOTE:

The safeguards and instructions appearing on these pages are not meant to cover all possible situations that may occur. Understand that common sense, caution, and care are factors, which cannot be built into any product. The person operating the unit must supply these factors.

D:\instr\jjinst 10/02/00

# REIMERS ELECTRA STEAM, INC.

4407 MARTINSBURG PIKE  
CLEAR BROOK, VA 22624  
PHONE: 540-662-3811 FAX: 540-665-8101

10/02/00

## OPERATING INSTRUCTIONS FOR JR. STEAM GENERATORS

The REIMERS JR. is a portable, hand-filled steam generator with a total 2-gallon Capacity, for operation at pressures from 5 to 85 PSI. Designed to the ASME/CSD-1` Boiler Code & registered with the National Board of Boiler Inspectors, it is safe when installed, maintained, and used properly.

**STANDARD EQUIPMENT INCLUDES:** Steam pressure gauge, steam valve, blowdown valve, water-fill funnel/valve, check valve, safety valve, water level gauge, low water cut off & electric cord/plug. **OPTIONAL:** Steam jet with electric solenoid valve.

**ADJUSTMENTS:** All controls have been set at the factory and should require no adjustments.

**MODIFICATION/MISUSE:** Any modification or misuse of this unit could result in a dangerous situation. Reimers Electra Steam, Inc. is not liable for any product that has been modified or improperly used.

**REGISTRATION:** Most states & cities require boiler registration/inspection. Check with local government authorities.

**REPAIR:** Only experienced personnel must attempt Repair of this unit. For repair instructions see the enclosed information.

**CAUTION: READ ALL INSTRUCTIONS BEFORE INSTALLATION/OPERATION.  
VALVES/PIPES ARE HOT WHEN UNDER PRESSURE OR HEATING UP. DO NOT TOUCH.**

## INSTALLATION

**PIPE INSTALLATION:** Steam piping must be of black pipe, not galvanized. An experienced steamfitter must do work. All state/local codes must be met.

**ELECTRICAL:** All wiring must be in accordance with the National Electric Code and any local codes that may apply. Wiring must be done by a competent, certified electrician. Use only copper wire.

**WATER (TAP WATER)** Ensure that all electrical components (Electric Foot Switches, etc.) are in a dry location not subject to steam or water.

**BLOWDOWN VALVE:** When the blowdown valve is utilized a large volume of hot water and steam is discharged. Ensure that this valve is properly piped for this discharge. State and local codes must be met as applicable.

**SAFETY VALVE:** Safety valve is designed to discharge hot steam when the set Pressure is exceeded. Ensure that the discharge port is pointing toward the back of the unit away from the operator and any aisles.

## OPERATION

**CAUTION: DO NOT POSITION FACE OR BODY OVER FILL FUNNEL. NEVER OPEN FILL VALVE WHEN UNIT IS UNDER PRESSURE.**

1. Close blowdown valve (#03346 rear of unit).
2. Open fill valve under funnel (#02490) & release air from unit by opening steam valve (02319). (Jewelry models: Release air by depressing foot switch with power switch #04213 on.)
3. Pour water into funnel (#MBJ-1) until it reaches the "Fill Level" mark beside the gauge glass. Do not overfill. Close fill valve (#02490).

**NOTE:** Overfilling will cause dirt and rust to be carried into the steam lines and onto goods. It will also cause the steam release valve to leak.

4. Connect electric cord to grounded 120-volt outlet (unit draws 12.5 amps).
5. Push Manual Reset (#20592). The light (#04215) will stay on until the preset working pressure is reached.
6. When the water level gets low, the unit will shut off. To refill, turn off power switch (#04213) & allow steam pressure to drop to zero. Fill with water as in 2 & 3.
7. Push Manual Reset (#20592) after refilling.

## MAINTENANCE & SAFETY NOTICE

The two brass nuts at the top & bottom of gauge glass (#04201) should be tightened until no leakage. **CAUTION:** Make no adjustments to the gauge glass unless the steam cleaner is unplugged, drained, all pressure is off the unit, and the unit is "cold to the touch".

### MAINTENANCE

**CAUTION:** REPAIR MUST BE BY EXPERIENCED PERSONNEL. ENSURE BOILER IS COLD, DRAINED AND HAS NO PRESSURE NOR ELECTRIC. ALL ELECTRICAL/STEAM SAFETY PRECAUTIONS MUST BE TAKEN.

**TO BLOWDOWN:** (FREQUENCY-MINIMUM ONCE PER WEEK) **CAUTION:** STAND CLEAR OF SCALDING WATER AND STEAM. ENSURE BLOWDOWN AND SAFETY VALVES ARE PROPERLY PIPED.

1. Turn power off, allow pressure to drop to 5 psig, & open blowdown valve.

**TO ADJUST STEAM PRESSURE:** (FREQUENCY-FACTORY PRESET/SELDOM REQ'D) **CAUTION:** STAND CLEAR OF SAFETY VALVE & SCALDING STEAM.

1. Be sure that electric power is off.
2. Remove cabinet top to gain access to operating pressure control. **CAUTION:** DO NOT ADJUST HI-LIMIT PRESSURE CONTROL MARKED: "DO NOT ADJUST. SAFETY DEVICE." THIS IS FACTORY PRESET FOR SAFETY.
3. Adjust black adjustment knob in direction indicated.

**TO TEST SAFETY VALVE:** (FREQUENCY-MINIMUM ONCE PER MONTH) **CAUTION:** STAND CLEAR OF SAFETY VALVE & SCALDING STEAM.

**NOTE:** Safety valve should be tested at minimum operating pressure. If discharge pipe is required, it should not be smaller than valve outlet & must be rigidly supported.

1. Hold trip lever open for five seconds in order to flush off valve seat.
2. Permit valve to "slap" shut. (If leakage evident, repeat test or replace valve).

**TO TEST ELEMENT:** Condition: Unit will not operate (Heat light on/unit not hot) when filled with water & reset pushed.

1. VOLTAGE TEST: Read 120 volts across element. If no voltage reading, check voltage at operating pressure control & low water cutoff. If voltage reads 120V, (Go to #2).
2. AMPERAGE TEST: Read 12.5 amps on each element wire. If no amp reading, replace heating element (PART # 02283).

**TO TEST LOW WATER CUTOFF:** (Condition) Boiler will not operate (Heat light not on/unit not hot) when filled with water & manual reset is pushed. **CAUTION:** USE ONLY INSULATED ELECTRICAL WIRE FOR JUMPER. DISCONNECT ELECTRICAL POWER WHEN ATTACHING JUMPER.

1. BYPASS CIRCUIT BOARD (STEP 1) *Jump circuit board terminals COM & NO.* This suspends low water protection. If light comes on, go to STEP #2, If not on, contact factory.
2. BYPASS PROBE ONLY (STEP 2) *Jump G-LLCO.* This will bypass probe. If light comes on, go to step #2A, if light not on, replace circuit board (PART #03465)
- 2A. Check probe for mineral deposits (see below).

**TO CLEAN PROBE CAUTION:** ENSURE BOILER IS COLD AND DRAINED & HAS NO PRESSURE NOR ELECTRIC.

1. Remove top cover/remove probe from top of unit
2. Clean probe rod with emery clothe
3. Reinstall probe & check wires for loose connections.

**TO REPLACE GAUGE GLASS:** (FREQUENCY = MINIMUM ONCE PER YEAR) **CAUTION:** ENSURE BOILER IS COLD, DRAINED & HAS NO PRESSURE NOR ELECTRIC. BE CAREFUL NOT TO BREAK GLASS

1. Close gauge glass valves (top and bottom).
2. Open petcock on bottom fixture of drain glass.
3. Loosen nuts at top and bottom of glass.
4. Slide glass up, pull out on bottom of glass and remove.
5. Install glass by reversing above procedure.

**NOTE:** Always install new rubber washers.

**TO REPLACE HEATING ELEMENT:** **CAUTION:** ENSURE BOILER IS COLD, DRAINED & HAS NO PRESSURE NOR ELECTRIC

1. Remove front right panel of cabinet.
2. Disconnect and label terminal wires.
3. Remove 4 nuts from element flange and pull out heating element.
4. Clean flange surface before installing new element & gasket.

**NO STEAM FLOW:**

1. Ensure boiler has water & pressure.
2. Close steam discharge valve & bleed/remove steam attachment (i.e. pressing iron, steam gun, etc.)
3. Slowly open steam discharge valve, if no flow, disconnect boiler from electricity, bleed off all steam pressure, drain water safely & let cool. Then remove steam discharge valve & examine.

NOTE: If your boiler is equipped with optional steam solenoid valve, check small brass strainer at the inlet side of steam solenoid valve. This small strainer is designed to prevent rust & dirt particles from entering the valve & ruining the seat. Clean strainer & replace. **CAUTION: ENSURE BOILER IS COLD, DRAINED & HAS NO PRESSURE NOR ELECTRIC**

**NOTE:**

ASME DATA PLATE IS LOCATED ON FRONT RIGHT SIDE OF PRESSURE VESSEL BEHIND LABEL STAMPED WITH NATIONAL BOARD NUMBER OF UNIT.

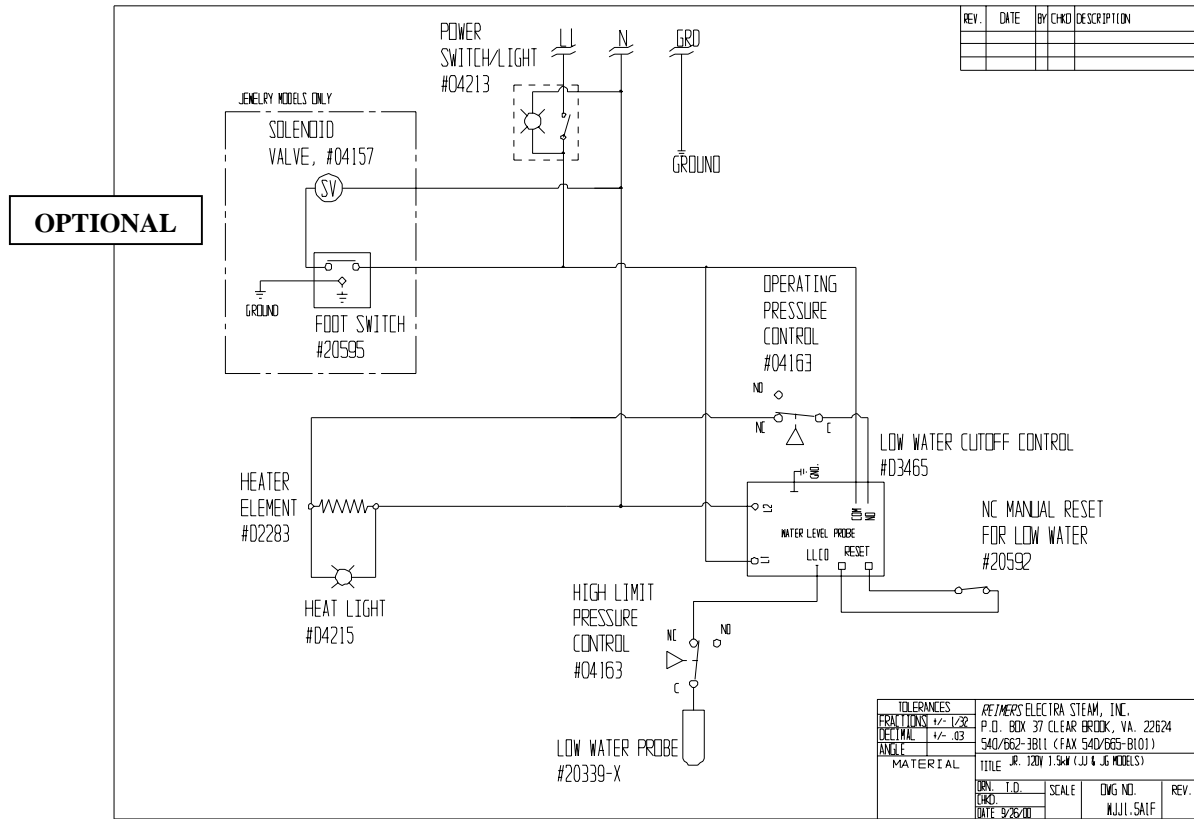

**PARTS LIST FOR MODEL JR. STEAM GENERATOR**

**EXTERIOR PARTS**

- 01314 NUTS FOR STUDS FOR ELEMENT FLANGE
  - 02006 GAUGE GLASS WASHER (RUBBER)
  - 02281 GASKET FOR ELEMENT/THERMOSTAT ASSY.
  - 02283 HEATING ELEMENT, 1500W/120-V
  - 02299 PRESSURE GAUGE 0-160 PSIG
  - 02319 VALVE, GLOBE 1/4" N.P.T.
  - 02396 GAUGE GLASS FIXTURE SET
  - 02448 GAUGE GLASS WASHER (BRASS)
  - 02462 VALVE 1/2" SWING CHECK
  - 02472 J VALVE, BALL 1/4" N.P.T.**
  - 02490 VALVE, BALL 1/2"
  - 02637 SAFETY VALVE 1/2" 100 PSI
  - 03346 VALVE, BALL 1/2" W/LATCH
  - 03465 LOW WATER CUT OFF (CIRCUIT BD) 120V
  - 04157 J SOLENOID 1/4" N.P.T. 120-V**
  - 04163 PRESSURE CONTROL
  - 04201 GAUGE GLASS 4.75"
  - 04213 SWITCH RED W/WHITE FRAME 125V
  - 04215 RED LIGHT W/WHITE FRAME 125V
  - 20058 J JET, BRASS #53**
  - MBJ187 LOW WATER CUT OFF (ELECTRODE)
  - 20592 RESET SWITCH
  - 20595 J FOOT SWITCH (ELECTRICAL)**
  - 20599 CORD 3-WIRE W/SLEEVES, PLUG CAP 120V
  - MBJ-1 FUNNEL (ALUMINUM)
- NOTE: J = Jewelry Model**

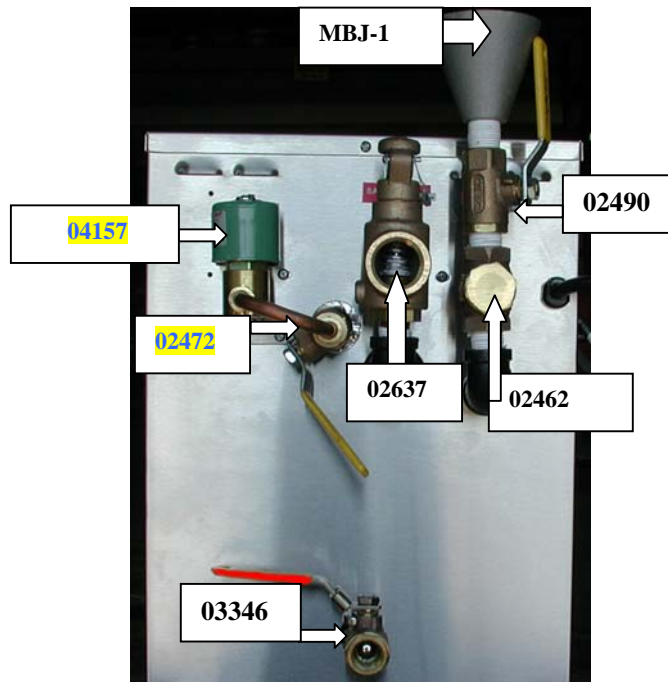

**VALVE OPERATION**

02472 STEAM OUTLET VALVE TO SHUT OFF STEAM TO SOLENOID VALVE 04157. THIS IS NORMALLY LEFT OPEN  
 02396 GAUGE GLASS FIXTURE SET TO SHUT OFF STEAM TO THE GAUGE GLASS NORMALLY BOTH TOP AND BOTTOM LEFT OPEN  
 02490 .5" BALL VALVE (YELLOW HANDLE) OPEN TO FILL, CLOSE TO OPERATE  
 03346 .5" BALL VALVE W/LATCH BOILER BLOWDOWN (RED HANDLE) (SEE CAUTIONS FOR BLOWDOWN) KEEP VALVE CLOSED EXCEPT FOR BLOWDOWN

**INTERIOR PARTS**

(REMOVE TOP PANEL)

