

**VAPOR POWER** INTERNATIONAL

**Instruction Manual**

**HWR MODEL**

**‘RESISTO-FLO’**

**ELECTRIC BOILER**

## **FOREWORD**

The HWR “Resisto-Flo” Electric Hot Water Boiler is designed to provide a compact packaged unit requiring a minimum of electrical and plumbing connections at the jobsite.

When installed according to these instructions, the boiler will provide years of reliable, low maintenance service.

Review both the installation and electrical drawings thoroughly before installing this boiler. A description of this boiler can be found in Bulletin 300, which is included at the end of this text.

## 1.0 INSTALLATION CLEARANCES

### 1.1 GENERAL

Locate boiler on a level surface. Be sure the location you select permits access to the control cabinet and allows for element removal as dimensioned on the installation drawing, and also that it is in accordance with the minimum spacing specified on the UL label, if provided.

**CAUTION**  
**ALL BOILERS EXCEPT MODELS HWR 1638 THRU 1654 ARE TO BE MOUNTED**  
**ON NONCOMBUSTIBLE FLOORING.**

### 1.2 MECHANICAL CLEARANCES

The clearances shown below are required for perimeter servicing of the boiler. Note: Front clearance to be 42" if opposing wall is conductive.

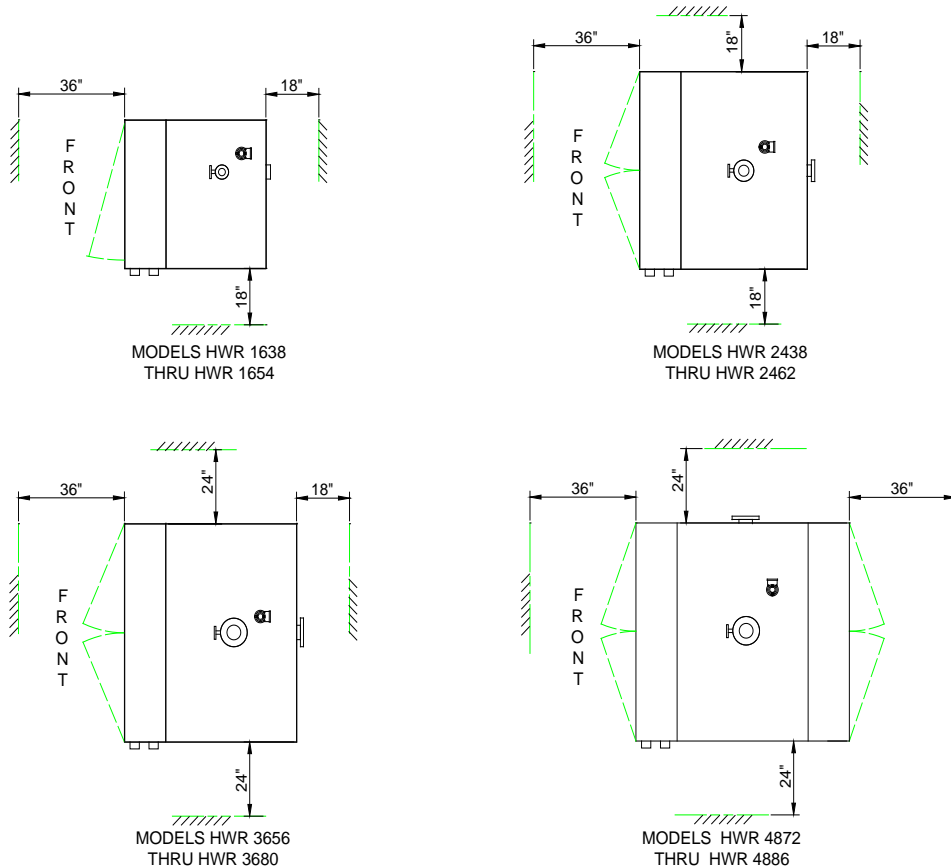

### 1.3 THERMAL CLEARANCES

Minimum thermal clearances should be maintained. If the boiler is UL listed, minimum clearances will be indicated on the UL Label. Otherwise, consult local codes and use good engineering judgment.

**CAUTION**

**THE BOILER ROOM TEMPERATURE SHOULD NOT EXCEED 30° C (86°F),  
WHICH SHOULD LIMIT THE TEMPERATURE WITHIN THE CONTROL  
CABINET TO A MAXIMUM OF 40°C (104°F).**

## **2.0 PLUMBING INSTALLATION**

### **2.1 SUPPLY AND RETURN LINES**

Connect supply piping to the water outlet at top of the boiler. The placement of a temperature sensor in this line close to the boiler is recommended to later monitor proper system operation.

Make the return connection to the water inlet at the rear of the boiler.

**NOTE: IT IS RECOMMENDED THAT ALL PIPING BE CHECKED FOR LEAKS BEFORE INSULATING.**

**NOTE: SYSTEM MAKE-UP WATER IS NORMALLY INTRODUCED AT OR NEAR THE EXPANSION TANK.**

### **2.2 SAFETY RELIEF VALVE(S)**

An ASME-approved safety relief valve (required by the ASME code to prevent system overpressure) is supplied with the boiler. This valve should be factory set at or below maximum working pressure of the boiler as stated on the boiler nameplate.

**NOTE: THE SYSTEM OPERATING PRESSURE MAY BE LIMITED BY THE SYSTEM COMPONENTS OTHER THAN THE BOILER, IT IS, THEREFORE ADVISABLE TO CHECK THE SAFE WORKING PRESSURE OF ALL COMPONENTS IN THE SYSTEM AND, IF NECESSARY, REPLACE THE SAFETY VALVE WITH A VALVE SET AT A LOWER PRESSURE, BUT SUFFICIENT CAPACITY ( $3500 \times \text{KW} = \text{BTU's/HR REQ'D}$ ) TO ASSURE COMPLETE SYSTEM PROTECTION.**

The discharge outlet of the relief valve should be piped to within 6" of the floor or to a safe point of discharge where no injury to persons could result from an unexpected discharge of hot water from the valve.

### **2.3 EXPANSION TANK**

An expansion tank must be provided to accommodate the increase in volume of the water in the heating system when the water is heated. The expansion

tank capacity should allow for increase in water volume of the heating system, including the boiler, radiators or coils, and all piping.

## **2.4 LOW WATER CUTOFF**

The boiler is as standard with a probe-type low water cutoff. If boiler is supplied with a ball/float type low water cutoff, a blowdown valve should be installed off the lower plugged cross to facilitate routine checking for proper function of the cutoff control.

## **2.5 HYDRO TEST**

Good practice, as well as, most local codes, dictates that a hydrostatic test, at a pressure equal to the safety valve setting, of the entire boiler system be performed prior to boiler start up. All leaks, both boiler and piping, should be “stopped” at this time.

**NOTE: SMALL LEAKS (LESS THAN 2 DROPS PER MINUTE) BETWEEN THE BODIES OF THE ELEMNT COMPRESSION FITTING AND THE ELEMENT FLANGES USUALLY STOP DURING THE FIRST FEW DAYS OF BOILER OPERATION. LARGER LEAKS, HOWEVER MAY NECESSITATE TIGHTENING OF THE COMPRESSION FITTING BODY. THIS IS ACCOMPLISHED BY FIRST REMOVING THE ASSOCIATED WIRES/JUMPERS, AND THEN TIGHTENING THE COMPRESSION BODY.**

**CAUTION:**

**DO NOT TORQUE BRASS COMPRESSION BODY OVER 70 FT LBS**

**NOTE: ALL PIPING, VALVES, AND FITTINGS MUST MEET THE REQUIREMENTS OF LOCAL REGULATING CODES. THE RESPONSIBILITY FOR THE INSTALLATION OF THIS BOILER RESTS WITH EITHER THE OWNER OR THE INSTALLING CONTRACTOR.**

### **3.0 ELECTRICAL INSTALLATION**

#### **3.1 ELECTRIC POWER SUPPLY**

Check the boiler nameplate for the KW rating, voltage, phase and ampacity. Check for the electrical supply to be certain it conforms with the boiler requirements.

Make electrical connections to main terminals housed within the top portion of the boiler control cabinet. Minimum wire size is given both on the electrical schematic and near the boiler terminals. On boilers, which require multiple conductors per phase, be certain that phasing is correct and that circuits are not “mixed” before energizing the boiler.

#### **3.2 GROUNDING**

Connect an equipment ground (minimum copper wire size is indicated on both the wiring schematic and the panel near the grounding lug) to the grounding lug located within the control cabinet.

**NOTE: ELECTRICAL INSTALLATION MUST BE MADE IN STRICT ACCORD WITH (1) THE BOILER’S ELECTRICAL SCHEMATIC, (2) THE NATIONAL ELECTRICAL CODE, AND (3) LOCAL ELECTRICAL CODES.**

#### **3.3 CONTROL CIRCUIT POWER SUPPLY**

On boilers, which are not supplied with 480/120V control transformer, a fused 120-volt power supply must be connected to the 2-pole terminal block housed within the top of the control cabinet. Refer to the boiler’s electrical schematic for required ampacity.

## **4.0 OPERATING INSTRUCTIONS**

**NOTE: PRIOR TO START UP, ANY HEATER OR CONTROL CABINET WHICH HAS BEEN EXPOSED TO DUSTY, WET, AND/OR HUMID CONDITIONS MUST BE THOROUGHLY CLEANED AND DRIED OUT. THE BUILD UP OF DUST AND RUST MAY RESULT IN EXCESSIVE DAMAGE UNLESS THE FOLLOWING PRECAUTIONS ARE UNDERTAKEN:**

- A. All electrical components should thoroughly cleaned and dried, and checked for loose connections.
- B. All electrical terminals should be thoroughly cleaned and dried, then hi-potted or meggered to assure there are no shorts to ground.
- C. Boiler should be inspected for stray objects, metal scraps, etc., which may have accumulated during installation. All such materials must be removed from the boiler prior to start up.
- D. All power wiring connections should be checked to assure tight connections.

**NOTE: HYDRO STEAM INDUSTRIES, AS MANUFACTURER OF THIS BOILER, WILL NOT BE RESPONSIBLE FOR DAMAGES INCURRED AT THE TIME BOILERS ARE STARTED UP UNLESS THE ABOVE STEPS HAVE BEEN TAKEN TO ASSURE THE BOILERS ARE PROPERLY PREPARED FOR STARTUP.**

**NOTE: MAXIMUM OPERATING CONDITIONS AS STATED ON THE BOILER NAMEPLATE ARE NOT TO BE EXCEEDED**

### **4.1 GENERAL**

The following section of this manual should be read in its entirety prior to operating the boiler.

### **4.2 PRELIMINARY CHECKS AND ADJUSTMENTS**

#### **4.2.1 TEMPERATURE CONTROL**

(Boilers supplied with proportioning step controls)

- A. Temperature Setting – Most Model HWR Boilers are provided with a proportioning type temperature control system which regulates the boiler output to match the system demand. This control should be set at the



required operating temperature but shall not exceed 250°F. Proper system operation can be checked via either the temperature gauge mounted on the boiler's supply piping or via the digital indication on the temperature control..

- B. Response/Range Adjustment - For boilers supplied with solid state step controls. A “span” adjustment on the temperature control adjusts the response/ differential of the control.
- C. Interstage Time Delay – Most solid state step controls now include adjustable interstage time delays. Some even include different delays for steps-on and steps-off which can be adjusted to minimize contactor cycles while still maintaining the required responsiveness of the control. Check the vendor-supplied literature provided at the rear of this manual.

#### 4.2.3 TEMPERATURE CONTROL

(Boilers supplied with one or more control thermostats)

Smaller HWR boilers are provided with one or more independent control thermostats, which switch on or off heating elements in accordance with their temperature setting. The differential between the thermostats should be set in accordance with system requirements.

#### 4.2.3 TEMPERATURE LIMIT THERMOSTATS

Check that that the auto and manual reset limits are set approximately 10% and 15%, respectively, greater than the temperature control but not to exceed 250°F.

#### 4.2.4 Auxiliary Controls

Other controls supplied with the boiler (eg, KW limit controls, cycle or delay timers, etc) should be set per the Engineer's specifications.

**NOTE: REFER TO DESCRIPTIVE LITERATURE IN THE REAR OF THIS MANUAL ON THE RESPECTIVE AUXILIARY CONTROLS.**

### 4.3 BOILER START UP

- A. Close drain valves.
- B. Open all system flow valves (inlet and outlet).
- C. Fill system with water. If a sight glass is provided, assure that it indicates full.

#### **WARNING**

**ENERGIZING THE HEATING ELEMENTS BEFORE COMPLETELY FILLING THE BOILER WILL DAMAGE THE HEATING ELEMENTS, THUS VOIDING THE WARRANTY. EVEN THOUGH A LOW WATER CUTOFF IS PROVIDED WITH THE BOILER, THE BOILER SHOULD NEVER BE SWITCHED ON WITHOUT FIRST ASSURING THAT THE BOILER IS COMPLETELY FILLED.**

#### 4.3.1 Control Circuit Checkout

If a separate branch circuit is provided for the 120V control, close the customer's 120V branch circuit power switch; if a control circuit transformer is provided, remove both the primary and secondary fuses and jump a 120V power supply to the secondary of the control transformer.

- A. Switch the control circuit power on, the switch should light to indicate that the control circuit power is energized.
- B. Circuits of heating elements will now be switched on by the step controller or pressure controllers, and pilot lights will light indicating that this function is taking place and, thus, that the controls are operating correctly.

**NOTE: IF A CONTACTOR "CHATTERS", BLOW IT OUT WITH AIR AND THEN CYCLE IT SEVERAL TIMES BY USING THE APPROPRIATE MANUAL ENABLE TOGGLE SWITCH.**

For boilers supplied with step controls, check the recycle feature by briefly interrupting the control power – the step control should recycle and start in a no- load condition. Perform maintenance checks of the control circuit per paragraph 5.2

Upon completion of the control circuit checkout, de-energize the control circuit, remove the jumpers and replace fuses, if applicable, and switch all of the circuit enable switches to the off position.

Energize the main power supply by closing the customer's branch circuit power switch.

Repeat steps A and B above to "start" the boiler.

Using the enable switches, gradually switch on the circuits.

Individually check each element circuit to assure that each leg is drawing its rated current.

**NOTE: SOME POWER FUSES MAY BLOW AT STARTING DUE TO WATER OR OTHER CONTAMINATION ON THE ELEMENT TERMINALS, SINCE THIS CONTAMINATION USUALLY "BURNS" FREE, MERELY CHECK THE CIRCUIT FOR A SHORT AND THEN REPLACE THE FUSE. IF A SHORT EXISTS, HOWEVER, REPLACE THE DEFECTIVE ELEMENT PER PARAGRAPH 5.3.3**

#### **4.4 BOILER SHUTDOWN**

Switch the control circuit power off. For boilers supplied with step controls, this will automatically recycle the step controller to no load so that when the boiler is again switched on, no contactors will be initially energized.

## **5.0 MAINTENANCE**

### **5.1 BOILER**

#### **5.1.1 Pressure Vessel**

Assure annual inspection by qualified ASME Boiler and Pressure Vessel Inspector. This inspection will cover the vessel and relief valve only.

#### **5.1.2 Heating Elements**

Make periodic checks for loose terminal and wiring connections. If all elements have been operating normally and all circuits draw rated current, no element tests are required. If element failure is suspected, the elements should be checked individually with an ohmmeter. Grounded elements may require a “Megger” for detection.

### **5.2 CONTROL CIRCUITS**

#### **5.2.1 Temperature Limit Thermostats**

Check cutout action of the limit thermostats by individually rotating the dials to below the boiler water temperature. The step control should reset to no load after each trip.

#### **5.2.2 Low Water Cutoff**

The LWCO level probe should be periodically checked. If there is any seepage between the conductor and its insulator or between the insulator and the compression fitting, replace the probe.

If the boiler is supplied with a float-type water cutoff, check the cutoff action by periodically blowing down the water column as quickly as possible. The step control should always reset to no load.

#### **5.2.3 Temperature Control**

A check of the proportioning temperature control system can be made by moving the set point of the controller up or down scale and noting the corresponding action of the step control. If the step control fails to follow in either direction, refer to the appropriate descriptive literature at the rear of this manual.

## **5.2 MAJOR COMPONENTS**

### **5.3.1 Contactors**

Periodic inspection and cleaning of contact should be made. Spot check for pitted, burned or welded contacts and inoperative coils. Discoloration of the contacts and/or Bakelite is usually indicative of a failed or failing contactor.

### **5.3.2 Fuses**

Check for loose fuse clips and wires. Inspect for discoloration of clips due to overheating.

### **5.3.3 Elements**

The resistance type immersion elements are field replaceable with standard tools. To replace defective elements, use the following procedure:

1. Turn off power to the boiler
2. Drain boiler below level of flange containing defective element.
3. Number and tag element wires and terminals to assure proper reassembly
4. Disconnect element wires to the flange
5. Remove flange from boiler nozzle
6. Remove buss bars, #10-32 nuts, insulators and washers from the defective element
7. Remove compression nut which holds the element in the flange
8. Slide element through flange (toward terminal side) far enough to cut element off behind compression ferrule
9. Pull defective element back through flange
10. Clean the ferrule seat in the flange
11. Make certain replacement element is correct size. Check both the voltage and KW rating stamped on the element itself
12. Slide new element through flange (from element bundle side), making sure orientation is correct.
13. Install new compression fitting (ferrule) on element. Shorter end of

element should extend at least 1/8" beyond compression nut after tightening (refer to element assembly sketch)

**NOTE: TIGHTEN COMPRESSION FITTING TO 70 FT LBS Brass, 110 FT LBS SS MAX.**

14. Reverse the procedure outlines in steps 4, 5 and 6 above using a new gasket.
15. Refill boiler and purge air from system.
16. Check for leaks both before and after system is pressurized.

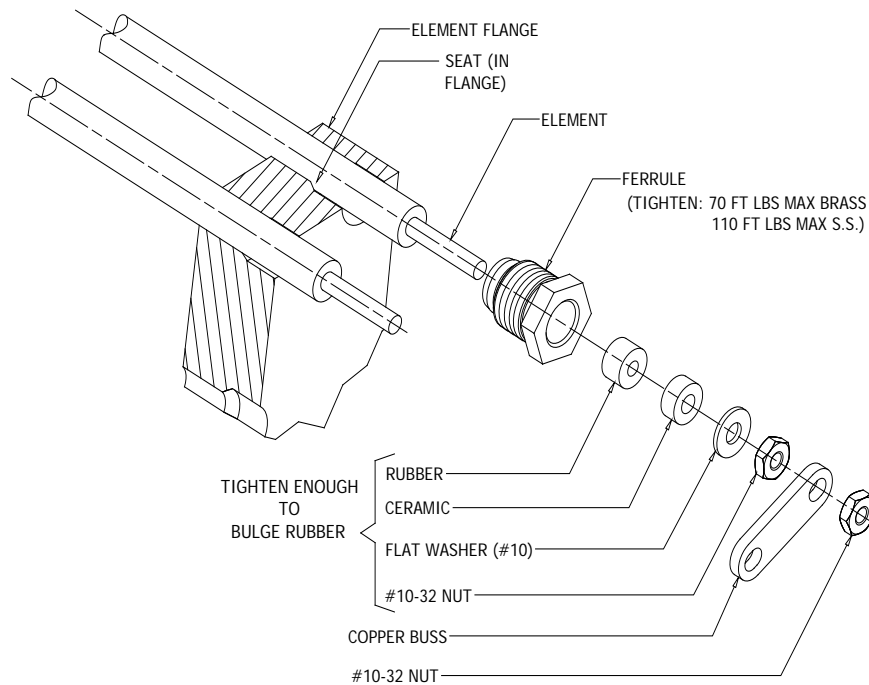

DETAIL - ELEMENT INSTALLATION

#### 5.4 CLEANING THE BOILER

Boiler should be drained and cleaned periodically to remove any accumulated scale or sludge. This can normally be done at the time of annual inspection unless experience indicated that more frequent cleaning is required.

# FLANGE WIRING DIAGRAM

WIRE JUMPER (TYP)

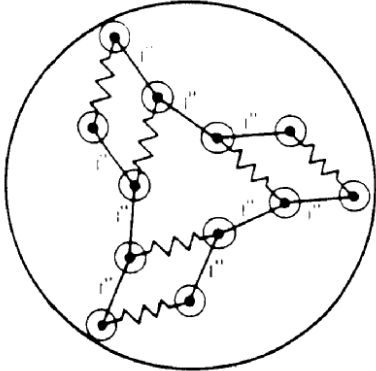

5" SINGLE DELTA

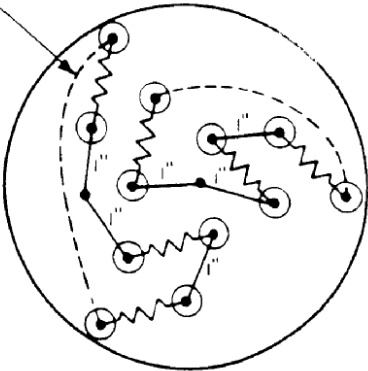

5" DOUBLE DELTA

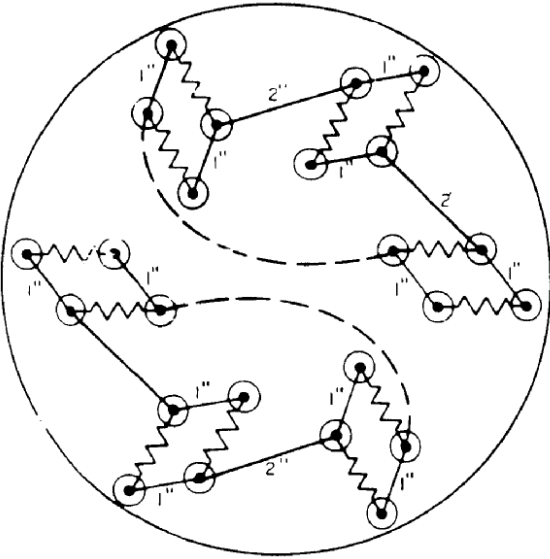

8" DOUBLE DELTA

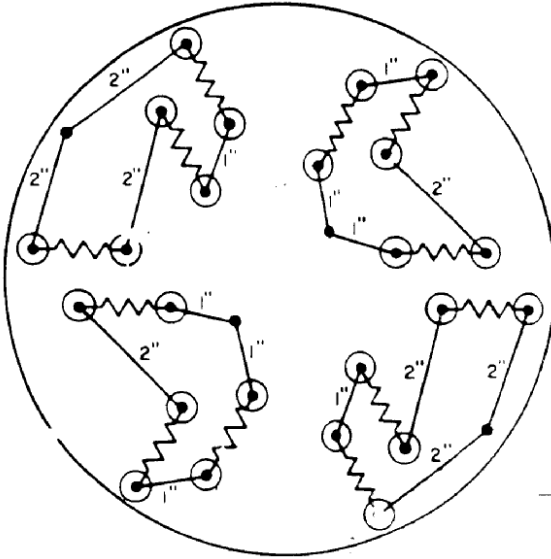

8" QUAD DELTA

# FLANGE WIRING DIAGRAM

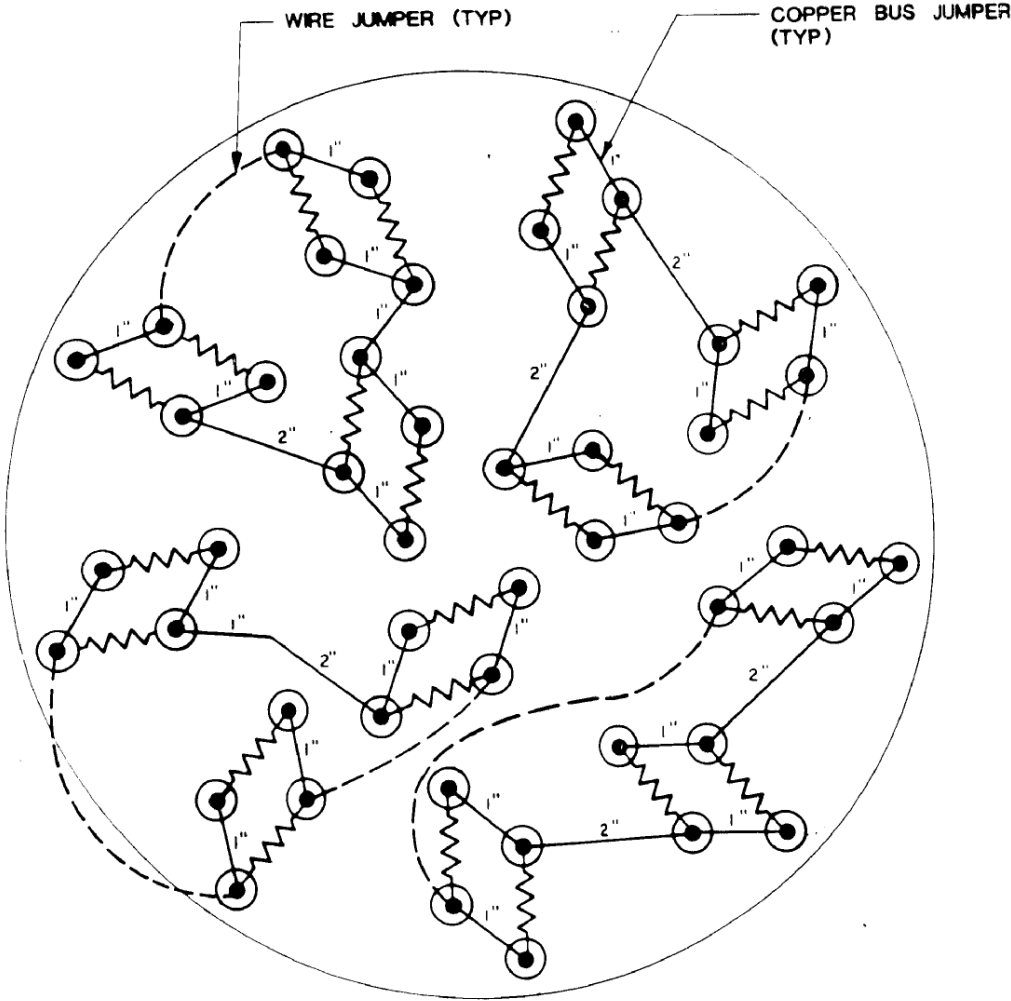

## 10" QUAD DELTA