

Cleaver-Brooks

DIVISION OF AQUA-CHEM, INC.

MILWAUKEE WISCONSIN 53201

PARTS REFERENCE

ITEM	REQ	PART NO.	DESCRIPTION
1	1	317-20	BURNER BACK PLATE (FABRICATED)
2	1	108-31	MANIFOLD BLOCK
3	1	SEE TABLE	TUBE & SLEEVE ASSY. (AIR)
4	1	SEE TABLE	TUBE & SLEEVE ASSY. (OIL)
5	1	458-28	SPIDER
6	2	873-7	IGNITION ELECTRODE
7	2	924-49	EXTENSION SPRING (SPECIFY LENGTH)
8	1	SEE TABLE	NOZZLE TIP & SWIRLER
9	1	277-37	NOZZLE BODY - SINGLE (SEE NOTE 2)
10	1	82-33	SWIRLER SPRING

ITEM	REQ	PART NO.	DESCRIPTION
11	1	853-218	O-RING
12	1	277-23	NOZZLE BODY-PILOT
13	1	940-528	BALL CHECK VALVE
14	1	108-10	OIL ORIFICE BLOCK
15	1	899-14	STRAINER-PILOT
16	1	SEE TABLE	NOZZLE-PILOT
17	1	82-34	SWIRLER SPRING-PILOT
18	1	251-7	NOZZLE TIP & SWIRLER-PILOT
19	1	SEE TABLE	DIFFUSER - NOT SHOWN
20	2	94-20	FEED THRU INSULATOR
*	1	SEE TABLE	BURNER DRAWER ASSEMBLY

ITEM	TABLE		
	100 SERIES	500-800 SERIES	
	CB50-100	CB50-80	CB70-100
3	90-84	90-84	90-111
4	90-88	90-85	90-112
8	251-3	251-5	251-5
16	899-29	899-23	899-23
*	429-175	429-185	429-183

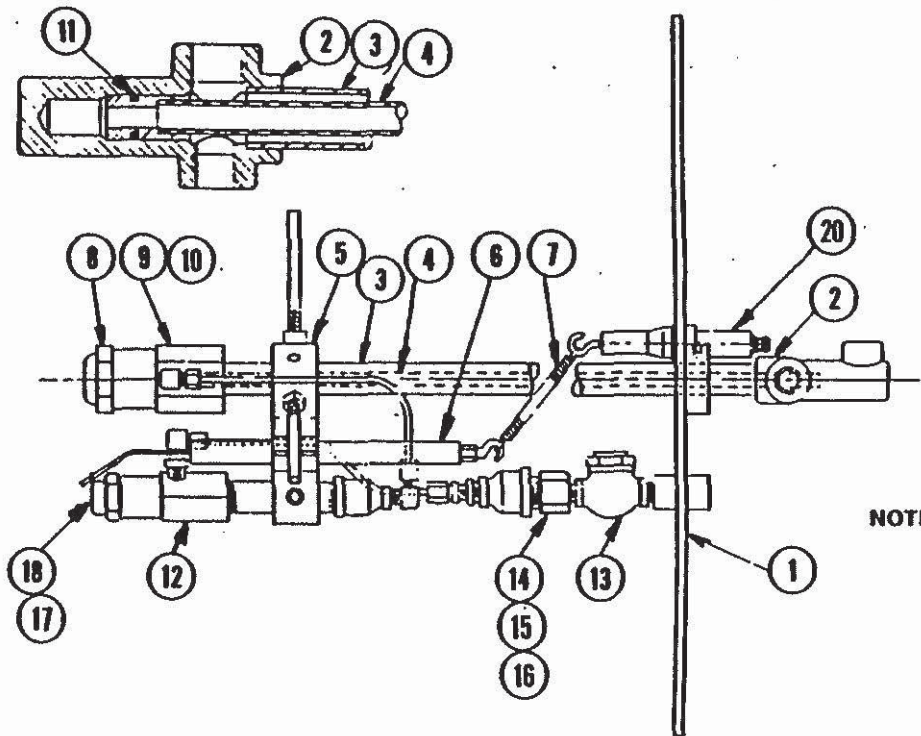

ITEM 19 - TABLE	
CB-50	275-65
CB-80	275-66
CB-70	275-67
CB-80	275-68
CB-100	275-69

NOTES: 1.) THIS IS THE ORIGINAL DESIGN WITH THE FABRICATED BURNER BACK PLATE IN MAY 1955. IT SHORTLY THEREAFTER WAS SUPERCEDED BY THE CASTED BURNER BACK PLATE.

2.) MULTIPLE NOZZLE BODIES ARE NOT AVAILABLE. TO CONVERT A MULTIPLE NOZZLE BODY TO A SINGLE NOZZLE, USE KIT #880-44.

DATE
4/1/86

BURNER DRAWER WITH LIGHT
OIL PILOT
CB50-100 HORSEPOWER
OLD STYLE

REVISION NO. 0
SHEET NO. 1 OF 16
REFERENCE NO. FTS.1.4

THIS INFORMATION IS CONFIDENTIAL AND IS NOT TO BE USED IN ANY WAY DETRIMENTAL TO THE COMPANY'S INTERESTS.

Cleaver-Brooks

DIVISION OF AQUACHEM, INC.

MILWAUKEE WISCONSIN 53201

PARTS REFERENCE

ITEM	REQ	PART NO.	DESCRIPTION
1	1	69-169	BURNER BACK PLATE (CASTED)
2	1	106-16	MANIFOLD BLOCK
3	1	SEE TABLE	TUBE & SLEEVE ASSY. (AIR)
4	1	SEE TABLE	TUBE & SLEEVE ASSY. (OIL)
5	1	458-26	SPIDER
6	2	873-7	IGNITION ELECTRODE
7	2	924-49	EXTENSION SPRING (SPECIFY LENGTH)
8	2	94-20	FEED THRU INSULATOR
9	1	277-37	NOZZLE BODY - SINGLE (SEE NOTE 2)
10	1	82-33	SWIRLER SPRING
11	1	SEE TABLE	NOZZLE TIP & SWIRLER
12	1	853-218	O-RING
13	1	277-23	NOZZLE BODY - PILOT
14	2	847-415	REDUCER BUSHING
15	3	845-308	ELBOW 1/8"

ITEM	REQ	PART NO.	DESCRIPTION
16	1	847-718	REDUCER BUSHING
17	1	857-141	NIPPLE
18	2	857-116	NIPPLE
19	1	940-526	BALL CHECK VALVE
20	1	106-10	OIL ORFICE BLOCK-PILOT
21	1	899-14	STRAINER-PILOT
22	1	SEE TABLE	NOZZLE-PILOT
23	1	847-527	REDUCER COUPLING
24	1	845-329	ADAPTER - STRAIGHT
25	2	936-60	TUBING 9" L.G. - PILOT
26	1	82-34	SWIRLER SPRING - PILOT
27	1	251-7	NOZZLE TIP & SWIRLER - PILOT
28	1	851-77	MICA SIGHT HOLE
28	1	85-11	SIGHT HOLE RETAINER
30	1	SEE TABLE	DIFFUSER - NOT SHOWN
*	1	SEE TABLE	BURNER DRAWER ASSEMBLY

ITEM 30 - TABLE	
CB-60	275-65
CB-80	275-68
CB-70	275-67
CB-80	275-68
CB-100	275-69 L.O.
CB-100	275-74 H.O.

ITEM	100 SERIES L.O.		500 & 600 SERIES H.O.	
	CB50-80	CB70-100	CB50-60	CB70-100
3	90-84	90-84	90-84	90-111
4	90-88	90-85	90-85	90-112
11	251-3	251-5	251-5	251-5
22	899-29	899-29	899-23	899-23
*	429-216	429-200	429-200	429-201

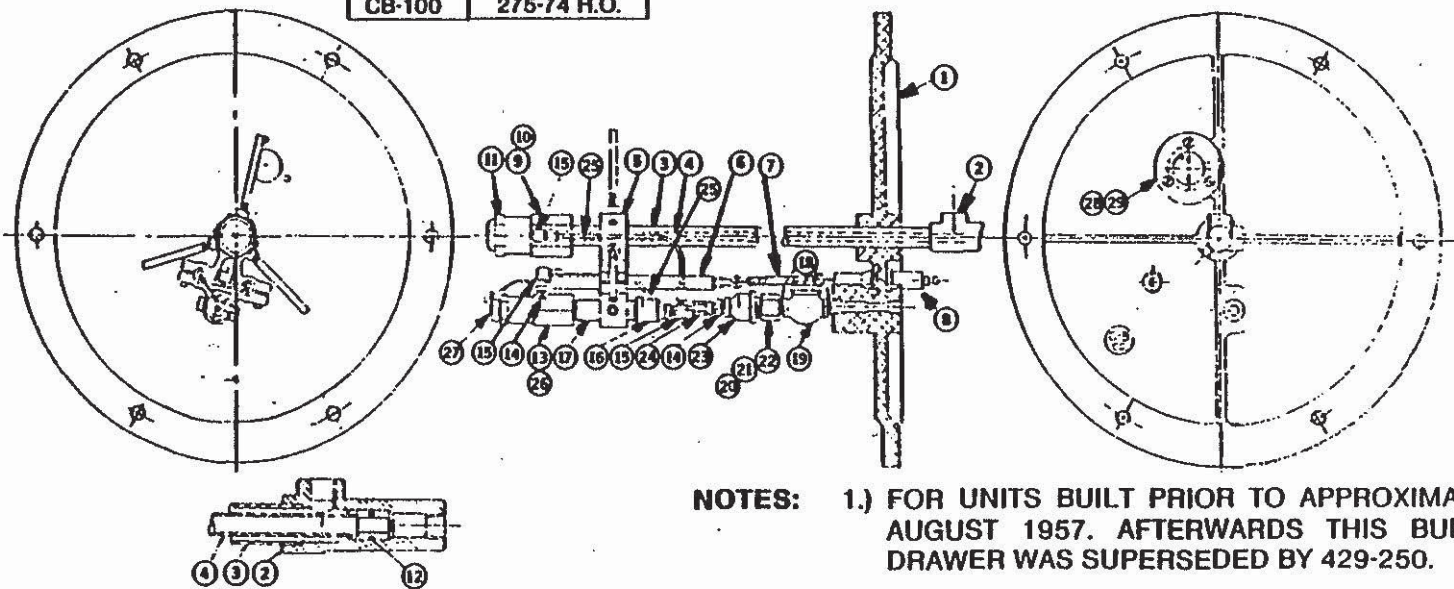

- NOTES:**
- 1.) FOR UNITS BUILT PRIOR TO APPROXIMATELY AUGUST 1957. AFTERWARDS THIS BURNER DRAWER WAS SUPERSEDED BY 429-250.
 - 2.) MULTIPLE NOZZLE BODIES ARE NOT AVAILABLE. TO CONVERT A MULTIPLE NOZZLE BODY TO A SINGLE NOZZLE, USE KIT #880-44.

DATE
4/1/86

BURNER DRAWER WITH LIGHT
OIL PILOT

CB50-100 HORSEPOWER
OLD STYLE

REVISION NO.

0

SHEET

NO. 2 OF 16

REFERENCE NO.

FT5.1.4

THIS INFORMATION IS CONFIDENTIAL AND IS NOT TO BE USED IN ANY WAY DETRIMENTAL TO THE COMPANY'S INTERESTS.

PARTS REFERENCE

MILWAUKEE WISCONSIN 53201

DIVISION OF AQUACHEM INC



DATE
4/1/86

BURNER DRAWER WITH LIGHT OIL PILOT

CB50-125A HORSEPOWER OLD STYLE

REVISION NO. 0 SHEET NO. 3 OF 16 REFERENCE NO. FT5.1.4

ITEM	REQ	PART NO.	DESCRIPTION
1	1	69-856	BURNER BACK PLATE (CASTED)
2	1	851-77	MICA SIGHT HOLE - 1-1/2"
3	1	85-11	SIGHT HOLE RETAINER
4	1	857-151	NIPPLE
5	1	90-141	TUBE & SLEEVE ASSY. (OIL)
6	1	853-55	O-RING
7	1	106-37	MANIFOLD BLOCK
8	1	90-140	TUBE & SLEEVE ASS'Y. (AIR)
9	1	90-139	BURNER DRAWER TUBE
10	1	8-577	ELECTRODE BRACKET
11	1	134-48	SPIDER
12	1	SEE TABLE	DIFFUSER
13	1	277-47	NOZZLE BODY
14	1	82-33	SWIRLER SPRING
15	1	SEE TABLE	NOZZLE TIP & SWIRLER
18	1	850-3	AIR PRESSURE GAUGE
17	2	845-42	ELBOW - FLARED
18	3	845-329	ADAPTER STRAIGHT

ITEM	REQ	PART NO.	DESCRIPTION
19	2	936-80	TUBING 7" LG. - PILOT
20	1	847-718	REDUCER COUPLING
21	1	857-141	NIPPLE
22	1	277-23	NOZZLE BODY - PILOT
23	1	82-34	SWIRLER SPRING - PILOT
24	1	251-7	NOZZLE TIP & SWIRLER - PILOT
25	2	847-415	REDUCER BUSHING
26	1	845-308	ELBOW 1/8"
27	2	857-116	NIPPLE
28	1	940-526	BALL CHECK VALVE
29	1	108-10	OIL ORIFICE BLOCK
30	1	SEE TABLE	NOZZLE WITH STRAINER
31	1	847-627	REDUCER COUPLING
32	2	94-179	FEED THRU INSULATOR
33	2	435-66	IGNITION ELECTRODE
34	2	924-49	EXTENSION SPRING (SPECIFY LENGTH)
35	2	845-46	ADAPTER - STRAIGHT
*	1	SEE TABLE	BURNER DRAWER ASSEMBLY

NOTES:

- FOR UNITS BUILT AFTER APPROXIMATELY AUGUST 1957 UNTIL THE REDESIGN TO THE ROTARY DAMPER (NEW STYLE).
- A CHANGE WAS MADE TO THE 500-600 SERIES BY ADDING A RETRACTABLE BURNER GUN JUST PRIOR TO THE REDESIGN. THE BURNER DRAWER ASSEMBLY PART NUMBER WAS CHANGED TO 429-323 AND A MICRO SWITCH 836-89 WAS ADDED. OTHERWISE REPLACEMENT PARTS ARE THE SAME.

ITEM 12 - TABLE	
CB-50	275-65
CB-80	275-68
CB-70	275-67
CB-80	275-68
CB-100	275-69
CB-125A	275-132

ITEM	TABLE	
	100 SERIES	500-600 SERIES
15	251-14 (50-100 HP)	
	251-19 (125A)	
30	899-29	899-23
*	429-250	

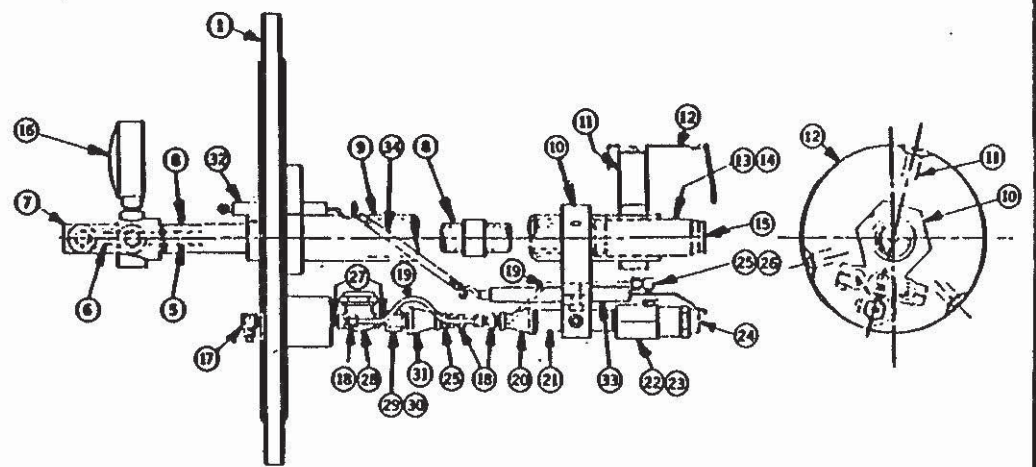
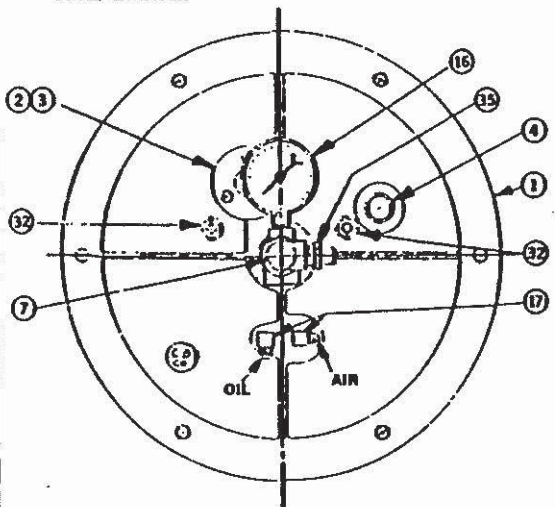

THIS INFORMATION IS CONFIDENTIAL AND IS NOT TO BE USED IN ANY WAY DETRIMENTAL TO THE COMPANY'S INTERESTS.

PARTS REFERENCE

MILWAUKEE WISCONSIN 53201
DIVISION OF AQUACHEM INC

Cleaver-Brooks

DATE
4/1/86

**BURNER DRAWER GAS AND OIL
COMBINATION WITH SIDE PILOT
CB50-100 HORSEPOWER
OLD STYLE**

REVISION NO. 0 SHEET 4 OF 16 REFERENCE NO. FT5.1.4

ITEM	REQ	PART NO.	DESCRIPTION
1	1	317-8	BURNER BACK PLATE (FABRICATED)
2	1	108-31	MANIFOLD BLOCK
3	1	90-84	TUBE AND SLEEVE ASSY.(AIR)
4	1	90-86	TUBE AND SLEEVE ASSY.(OIL)
5	1	277-26	NOZZLE BODY - SINGLE (SEE NOTE 2)
6	1	82-33	SWIRLER SPRING
7	1	458-23	SPIDER
8	1	824-14	COLLAR
9	1	56-17	LOCKING PIN
10	1	48-9	LOCKING PLATE
11	1	868-8	FASTENER LATCH
12	1	8-58	LIMIT SWITCH BRACKET
13	1	838-89	LIMIT SWITCH
14	1	853-218	O-RING
15	1	SEE TABLE	NOZZLE TIP & SWIRLER
16	1	SEE TABLE	DIFFUSER - NOT SHOWN
*	1	SEE TABLE	BURNER DRAWER ASSEMBLY

- NOTES:**
- 1.) THIS IS THE ORIGINAL DESIGN WITH THE FABRICATED BURNER BACK PLATE IN MARCH 1955. IT SHORTLY THEREAFTER WAS SUPERCEDED BY THE CASTED BURNER BACK PLATE.
 - 2.) MULTIPLE NOZZLE BODIES ARE NOT AVAILABLE. TO CONVERT A MULTIPLE NOZZLE BODY TO A SINGLE NOZZLE, USE KIT #880-44.

ITEM	TABLE			
	SERIES 200 L.O.		SERIES 300 & 400 H.O.	
	CB50-80	CB-100	CB50-60	CB70-100
15	251-3	251-4	251-5	251-5
*	429-162	429-163	429-161	429-160

ITEM 16 - TABLE	
CB-50	275-36
CB-60	275-37
CB-70	275-38
CB-80	275-39
CB-100	275-52 L.O.
CB-100	275-50 H.O.

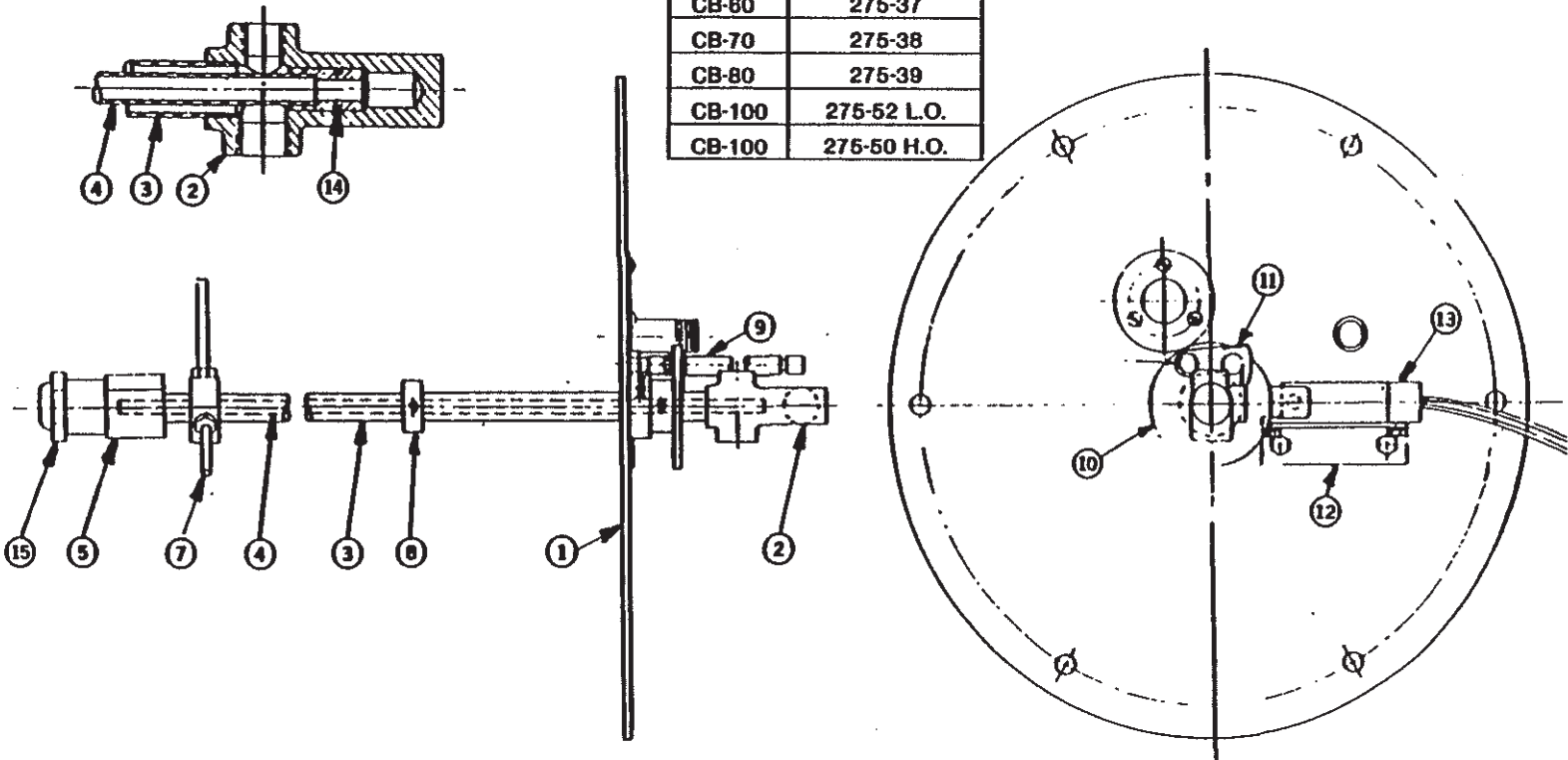

THIS INFORMATION IS CONFIDENTIAL AND IS NOT TO BE USED IN ANY WAY DETRIMENTAL TO THE COMPANY'S INTERESTS.

Cleaver-Brooks

DIVISION OF AQUA-CHEM, INC.

MILWAUKEE WISCONSIN 53201

PARTS REFERENCE

ITEM	REQ	PART NO.	DESCRIPTION
1	1	59-188	BURNER BACK PLATE (CASTED)
2	1	851-77	MICA SIGHT HOLE 1 1/2"
3	1	65-11	SIGHT HOLE RETAINER
4	1	SEE TABLE	TUBE & SLEEVE ASS'Y. (OIL)
5	1	SEE TABLE	TUBE & SLEEVE ASS'Y. (AIR)
6	1	458-23	SPIDER
7	1	277-28	NOZZLE BODY - SINGLE (SEE NOTE 2)
8	1	82-33	SWIRLER SPRING
9	1	SEE TABLE	NOZZLE TIP & SWIRLER
10	1	57-21	GAS PILOT PIPE
11	1	108-18	MANIFOLD BLOCK
12	1	850-55	AIR PRESSURE GAUGE
13	1	857-151	NIPPLE
14	1	857-175	NIPPLE
15	1	284-8	TEE

ITEM	REQ	PART NO.	DESCRIPTION
18	1	845-312	ADAPTOR
17	1	435-11	IGNITION ELECTRODE
18	1	853-218	O-RING
19	1	48-11	LOCKING PLATE
20	1	8-171	LIMIT SWITCH BRACKET
21	1	836-89	LIMIT SWITCH
22	1	824-14	COLLAR
23	1	886-8	FASTNER LATCH
24	1	58-17	LOCKING PIN
25	1	SEE TABLE	DIFFUSER - NOT SHOWN
*	1	SEE TABLE	BURNER DRAWER ASSEMBLY

ITEM 25 - TABLE	
CB-50	275-85
CB-60	275-86
CB-70	275-87
CB-80	275-88
CB-100	275-89
CB-100	275-74

ITEM	TABLE		
	CB50-60 SERIES 200	CB70-100 SERIES 200 CB50-60 SERIES 300 & 400	CB70-100 SERIES 300 & 400
4	90-88	90-86	90-112
6	90-84	90-84	90-111
9	251-3	251-5	251-5
*	429-213	429-198	429-197

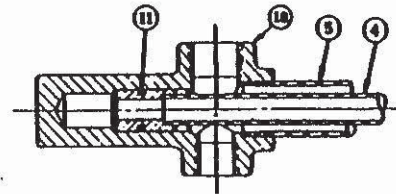

NOTES:

- 1.) FOR UNITS BUILT PRIOR TO APPROXIMATELY AUGUST 1957, THIS CASTED BACK PLATE REPLACED THE ORIGINAL FABRICATED BACK PLATE DESIGN.
- 2.) MULTIPLE NOZZLE BODIES ARE NOT AVAILABLE. TO CONVERT A MULTIPLE NOZZLE BODY TO A SINGLE NOZZLE, USE KIT #880-44.

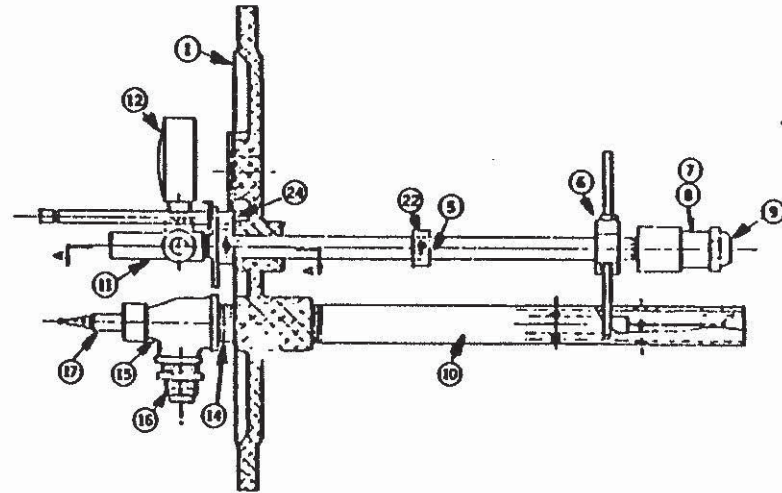
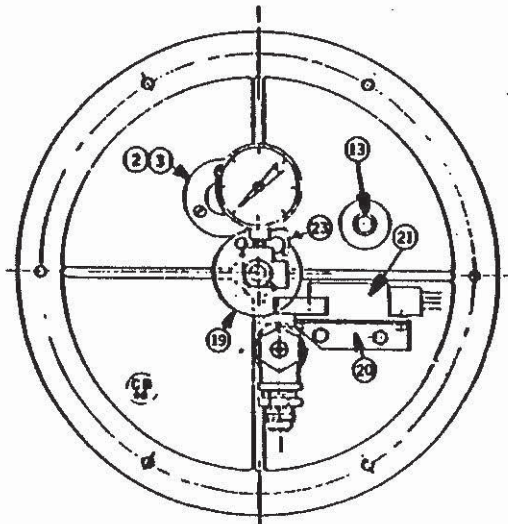

THIS INFORMATION IS CONFIDENTIAL AND IS NOT TO BE USED IN ANY WAY DETRIMENTAL TO THE COMPANY'S INTERESTS.

DATE
4/1/86

REVISION NO. 0
SHEET 5 OF 16
REFERENCE NO. FT5.1.4

BURNER DRAWER GAS AND OIL
COMBINATION WITH GAS PILOT
OLD STYLE

Cleaver-Brooks

DIVISION OF AQUA-CHEM, INC.

MILWAUKEE WISCONSIN 53201

PARTS REFERENCE

ITEM	REQ	PART NO.	DESCRIPTION
1	1	SEE TABLE	BURNER BACK PLATE (CASTED)
2	1	851-77	MICA SIGHT HOLE - 1-1/2"
3	1	85-11	SIGHT HOLE RETAINER
4	1	857-151	NIPPLE
5	1	90-141	TUBE & SLEEVE ASS'Y. (OIL)
6	1	853-55	O-RING
7	1	108-37	MANIFOLD BLOCK
8	1	90-140	TUBE & SLEEVE ASS'Y. (AIR)
9	1	90-139	BURNER DRAWER TUBE
10	1	134-48	SPIDER
11	1	SEE TABLE	DIFFUSER
12	1	277-47	NOZZLE BODY ASS'Y.
13	1	82-33	SWIRLER SPRING
14	1	SEE TABLE	NOZZLE TIP & SWIRLER
15	1	850-3	AIR PRESSURE GAUGE
16	1	57-21	GAS PILOT PIPE
17	1	857-175	NIPPLE
18	1	435-11	IGNITION ELECTRODE

ITEM	REQ	PART NO.	DESCRIPTION
19	1	157-47	TEE
20	1	845-312	ADAPTER - STRAIGHT
21	1	8-171	LIMIT SWITCH BRACKET
22	1	836-89	LIMIT SWITCH
23	1	46-14	LOCKING PLATE
24	1	56-18	LOCKING PIN
25	1	866-8	FASTENER LATCH
26	1	847-417	REDUCER BUSHING
27	1	859-104	STREET ELBOW
28	1	857-142	NIPPLE
29	1	847-543	REDUCER ELBOW
30	1	904-38	RUBBER GROMMET
31	1	34-7	IGNITION ELECTRODE GLAND
32	1	857-33	NIPPLE
33	1	848-18	CONNECTOR
34	1	827-6	CABLE 10 - 1/4" LG. (SPECIFY LENGTH)
35	1	848-3	CONNECTOR
*	1	SEE TABLE	BURNER DRAWER ASSEMBLY

ITEM	TABLE						
	LIGHT OIL				HEAVY OIL	LIGHT OR HEAVY OIL	
	CB50	CB60	CB70	CB80	CB50-80	CB100	CB125A
1	59-860	59-860	59-860	59-860	59-1270	59-860	59-1270
11	275-65	275-68	275-87	275-68	275-138	275-89	275-132
14	251-14	251-14	251-14	251-14	251-23	251-14	251-10
*	429-1081	429-1082	429-1083	429-1084	429-389	429-1085	429-378

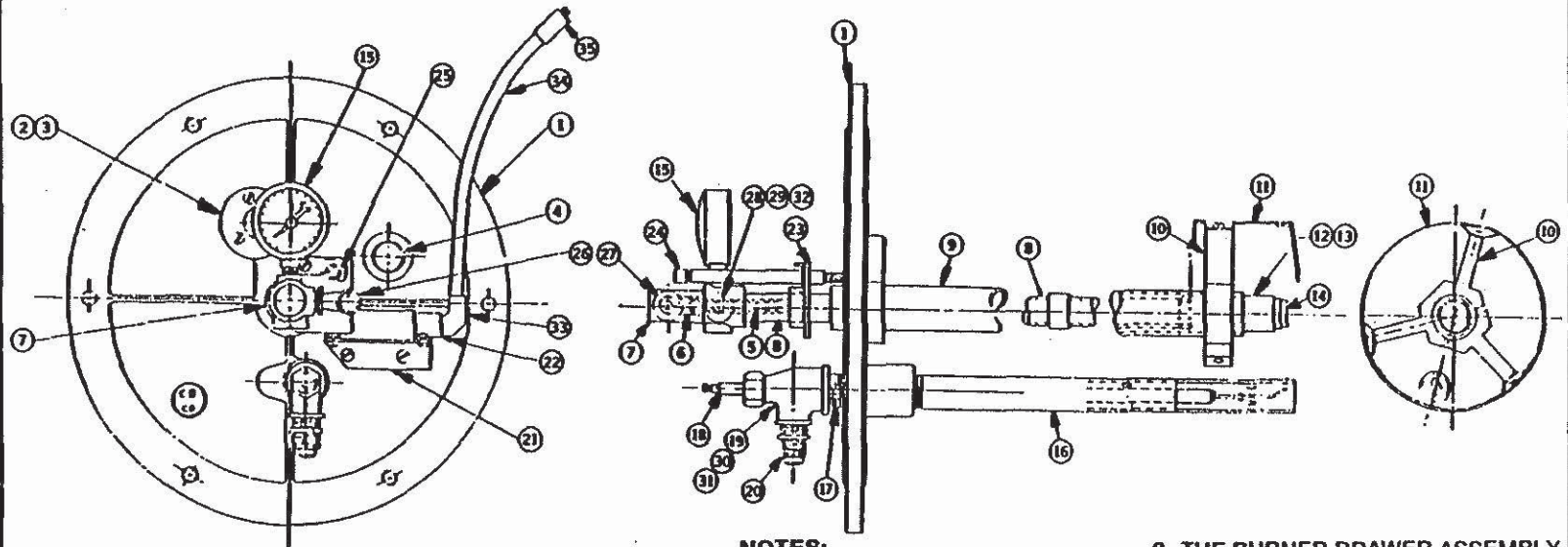

NOTES:
 1. FOR UNITS BUILT AFTER APPROXIMATELY AUGUST, 1957 UNTIL THE REDESIGN TO THE ROTARY DAMPER (NEW STYLE).

2. THE BURNER DRAWER ASSEMBLY PART NUMBER 429-251 WHICH COVERED ALL BOILER SIZES WAS OBSOLETE AND NEW NUMBERS TAKEN OUT FOR EACH SIZE.

DATE

4/1/86

BURNER DRAWER GAS AND OIL COMBINATION WITH GAS PILOT CB50-100 HORSEPOWER OLD STYLE

REVISION NO. 0 SHEET NO. 6 OF 16 REFERENCE NO. FT5.1.4

THIS INFORMATION IS CONFIDENTIAL AND IS NOT TO BE USED IN ANY WAY DETRIMENTAL TO THE COMPANY'S INTERESTS.

TABLE			
ITEM	100 SERIES	500 & 600 SERIES	
	CB50-80	CB50-60	CB70-100
6	90-86	90-85	90-85
9	251-3	251-5	251-5
*	429-117	429-93	429-94

ITEM	REQ	PART NO.	DESCRIPTION
1	1	317-38	BURNER BACK PLATE (FABRICATED)
2	1	106-31	MANIFOLD BLOCK
3	1	90-84	TUBE & SLEEVE ASS'Y. (AIR)
4	1	82-33	SWIRLER SPRING
5	1	860-39	SETSCREW
6	1	SEE TABLE	TUBE & SLEEVE ASS'Y. (OIL)
7	1	456-23	SPIDER
8	1	853-218	O-RING
9	1	SEE TABLE	NOZZLE TIP & SWIRLER
10	1	SEE TABLE	DIFFUSER - NOT SHOWN
*	1	SEE TABLE	BURNER DRAWER ASSEMBLY

ITEM 10 - TABLE	
CB-50	275-36
CB-60	275-37
CB-70	275-38
CB-80	275-39
CB-100	275-50

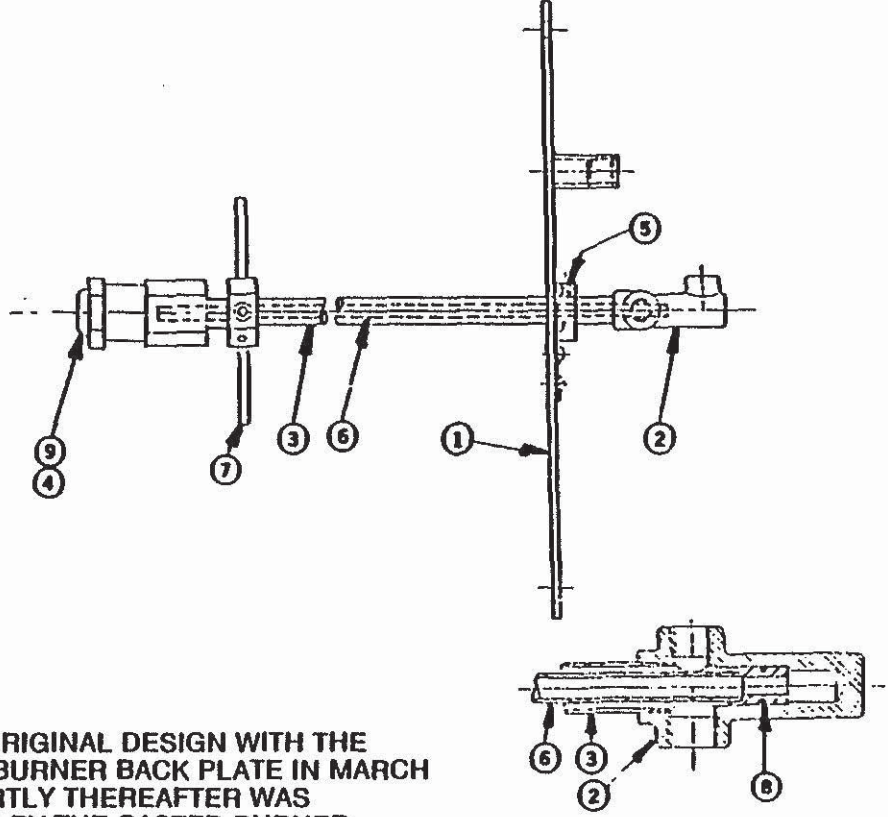

- NOTES:**
- 1.) THIS IS THE ORIGINAL DESIGN WITH THE FABRICATED BURNER BACK PLATE IN MARCH 1954. IT SHORTLY THEREAFTER WAS SUPERCEDED BY THE CASTED BURNER BACK PLATE.
 - 2.) MULTIPLE NOZZLE BODIES ARE NOT AVAILABLE. TO CONVERT A MULTIPLE NOZZLE BODY TO A SINGLE, USE KIT #880-44.

Cleaver
Brooks
 DIVISION OF AQUA-CHEM INC
 MILWAUKEE WISCONSIN 53201
PARTS REFERENCE

DATE
 4/1/86

OIL BURNER DRAWER WITH SIDE PILOT
 CB50-100 HORSEPOWER
 OLD STYLE

REVISION NO. 0 SHEET NO. 7 OF 16 REFERENCE NO. FT5.1.4

THIS INFORMATION IS CONFIDENTIAL AND IS NOT TO BE USED IN ANY WAY DETRIMENTAL TO THE COMPANY'S INTERESTS.

DIVISION OF AQUA-CHEM, INC.

Cleaver-Brooks

MILWAUKEE WISCONSIN 53201

PARTS REFERENCE

ITEM	REQ	PART NO.	DESCRIPTION
1	1	69-175	BURNER BACK PLATE (CASTED)
2	1	851-77	MICA SIGHT HOLE - 1 1/2"
3	1	65-11	SIGHT HOLE RETAINER
4	1	SEE TABLE	TUBE & SLEEVE ASS'Y. (OIL)
5	1	SEE TABLE	TUBE & SLEEVE ASS'Y. (AIR)
6	1	456-23	SPIDER
7		N.A.	NOZZLE BODY (SEE NOTE 2)
8	1	82-33	SWIRLER SPRING
9		251-5	NOZZLE TIP & SWIRLER
10	1	67-81	GAS PILOT PIPE
11	1	106-16	MANIFOLD BLOCK
12	1	850-55	AIR PRESSURE GAUGE
13	1	284-8	TEE
14	1	845-312	ADAPTER
15	1	435-11	IGNITION ELECTRODE
16	1	853-218	O-RING
17	1	SEE TABLE	DIFFUSER - NOT SHOWN
18	1	904-36	RUBBER GROMMET
*	1	SEE TABLE	BURNER DRAWER ASSEMBLY

TABLE		
ITEM	500-800 SERIES	
	CB50-60	CB70-100
4	90-85	90-112
5	90-84	90-111
*	429-198	429-195

ITEM 17 TABLE	
CB-50	275-65
CB-60	275-66
CB-70	275-87
CB-80	275-68
CB-100	275-74

DATE
4/1/86

OIL BURNER DRAWER WITH GAS PILOT
CB50-100 HORSEPOWER
OLD STYLE

REVISION NO. 0 SHEET 8 OF 16 REFERENCE NO. FTS.1.4

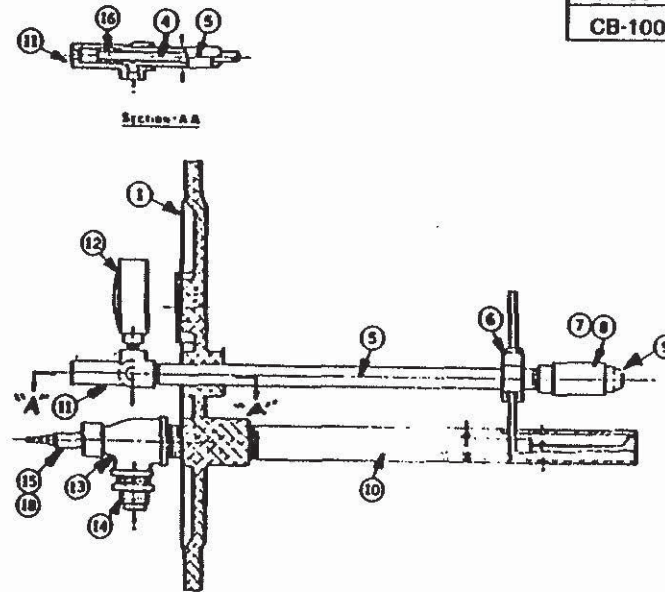
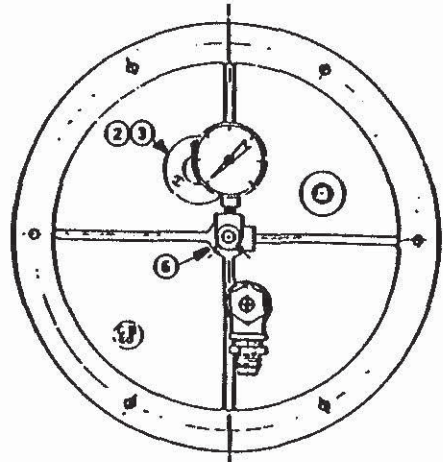

- NOTES:**
- 1.) FOR UNITS BUILT PRIOR TO APPROXIMATELY AUGUST 1957. AFTERWARDS THIS BURNER DRAWER WAS SUPERCEDED BY 429-252.
 - 2.) MULTIPLE NOZZLE BODIES ARE NOT AVAILABLE. TO CONVERT A MULTIPLE NOZZLE BODY TO A SINGLE NOZZLE, USE KIT #880-44.

ITEM	REQ	PART NO.	DESCRIPTION
16	1	57-21	GAS PILOT PIPE
17	1	857-175	NIPPLE
18	1	435-11	IGNITION ELECTRODE
19	1	284-8	TEE
20	1	845-312	ADAPTER - STRAIGHT
21	1	845-46	ADAPTER - STRAIGHT
22	1	904-38	RUBBER GROMMET
*	1	429-252	BURNER DRAWER ASSEMBLY

ITEM	REQ	PART NO.	DESCRIPTION
1	1	59-877	BURNER BACK PLATE (CASTED)
2	1	851-77	MICA SIGHT HOLE - 1-1/2"
3	1	65-11	SIGHT HOLE RETAINER
4	1	857-151	NIPPLE
5	1	90-141	TUBE & SLEEVE ASS'Y. (OIL)
6	1	853-65	O-RING
7	1	108-37	MANIFOLD BLOCK
8	1	90-140	TUBE & SLEEVE ASS'Y. (AIR)
9	1	90-139	BURNER DRAWER TUBE
10	1	134-48	SPIDER
11	1	SEE TABLE	DIFFUSER
12	1	277-47	NOZZLE BODY
13	1	82-33	SWIRLER SPRING
14	1	251-14	NOZZLE TIP & SWIRLER
15	1	850-3	AIR PRESSURE GAUGE

NOTES:

- 1.) FOR UNITS BUILT AFTER APPROXIMATELY AUGUST 1957 UNTIL THE RETRACTABLE GUN WAS ADDED. THIS BURNER DRAWER WAS SUPERCEDED BY 429-251.

TABLE	
CB-50	275-65
CB-60	275-68
CB-70	275-67
CB-80	275-68
CB-100	275-69

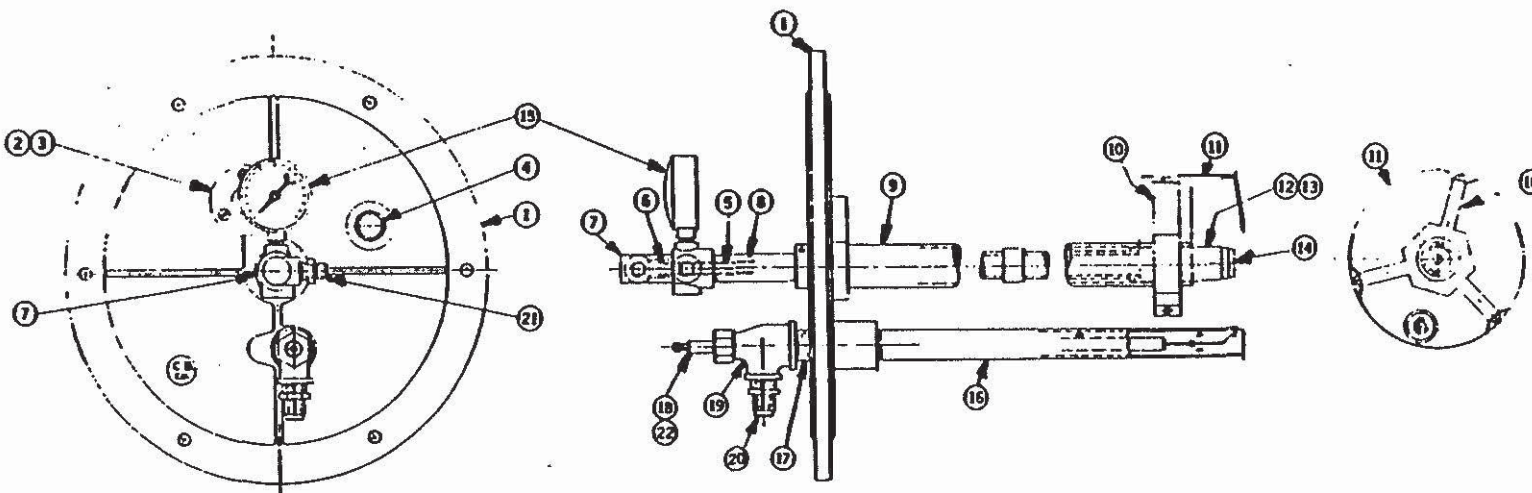

Cleaver
Brooks

DIVISION OF AQUA-CHEM, INC.

MILWAUKEE, WISCONSIN 53201

PARTS REFERENCE

DATE

4/1/86

OIL BURNER DRAWER WITH GAS PILOT

CB50-100 HORSEPOWER

OLD STYLE

REVISION NO.

0

SHEET

NO. 9 OF 16

REFERENCE NO.

FT6.1.4

THIS INFORMATION IS CONFIDENTIAL AND IS NOT TO BE USED IN ANY WAY DETRIMENTAL TO THE COMPANY'S INTERESTS.

Cleaver-Brooks

DIVISION OF AQUA-CHEM, INC.

MILWAUKEE, WISCONSIN 53201

PARTS REFERENCE

ITEM	REQ	PART NO.	DESCRIPTION
1	1	SEE TABLE	BURNER BACK PLATE (CASTED)
2	1	851-77	MICA SIGHT HOLE - 1 1/2"
3	1	65-11	SIGHT HOLE RETAINER
4	1	857-151	NIPPLE
5	1	90-141	TUBE & SLEEVE ASS'Y. (OIL)
6	1	853-55	O-RING
7	1	106-37	MANIFOLD BLOCK
8	1	90-140	TUBE & SLEEVE ASS'Y. (AIR)
9	1	90-139	BURNER DRAWER TUBE
10	1	134-46	SPIDER
11	1	SEE TABLE	DIFFUSER
12	1	277-47	NOZZLE BODY ASS'Y.
13	1	82-33	SWIRLER SPRING
14	1	SEE TABLE	NOZZLE TIP & SWIRLER
15	1	850-3	AIR PRESSURE GAUGE
16	1	57-21	GAS PILOT PIPE
17	1	857-175	NIPPLE
18	1	436-11	IGNITION ELECTRODE

ITEM	REQ	PART NO.	DESCRIPTION
19	1	157-47	TEE
20	1	845-312	ADAPTER - STRAIGHT
21	1	8-171	LIMIT SWITCH BRACKET
22	1	836-89	LIMIT SWITCH
23	1	48-14	LOCKING PLATE
24	1	58-18	LOCKING PIN
25	1	866-8	FASTENER LATCH
26	1	847-417	REDUCER BUSHING
27	1	859-104	STREET ELBOW
28	1	857-142	NIPPLE
29	1	847-543	REDUCER ELBOW
30	1	904-36	RUBBER GROMMET
31	1	34-7	IGNITION ELECTRODE GLAND
32	1	857-33	NIPPLE
33	1	848-16	CONNECTOR
34	1	827-6	CABLE 10 - 1/4" LG. (SPECIFY LENGTH)
35	1	848-3	CONNECTOR
*	1	SEE TABLE	BURNER DRAWER ASSEMBLY

ITEM	TABLE							
	LIGHT OIL				HEAVY OIL		LIGHT OR HEAVY OIL	
	CB50	CB60	CB70	CB80	CB50-80	CB100	CB125A	
1	59-860	59-860	59-860	59-860	59-1270	59-860	59-1270	
11	275-65	275-66	275-67	275-68	275-138	275-69	275-132	
14	251-14	251-14	251-14	251-14	251-23	251-14	251-10	
*	429-1081	429-1082	429-1083	429-1084	429-389	429-1085	429-378	

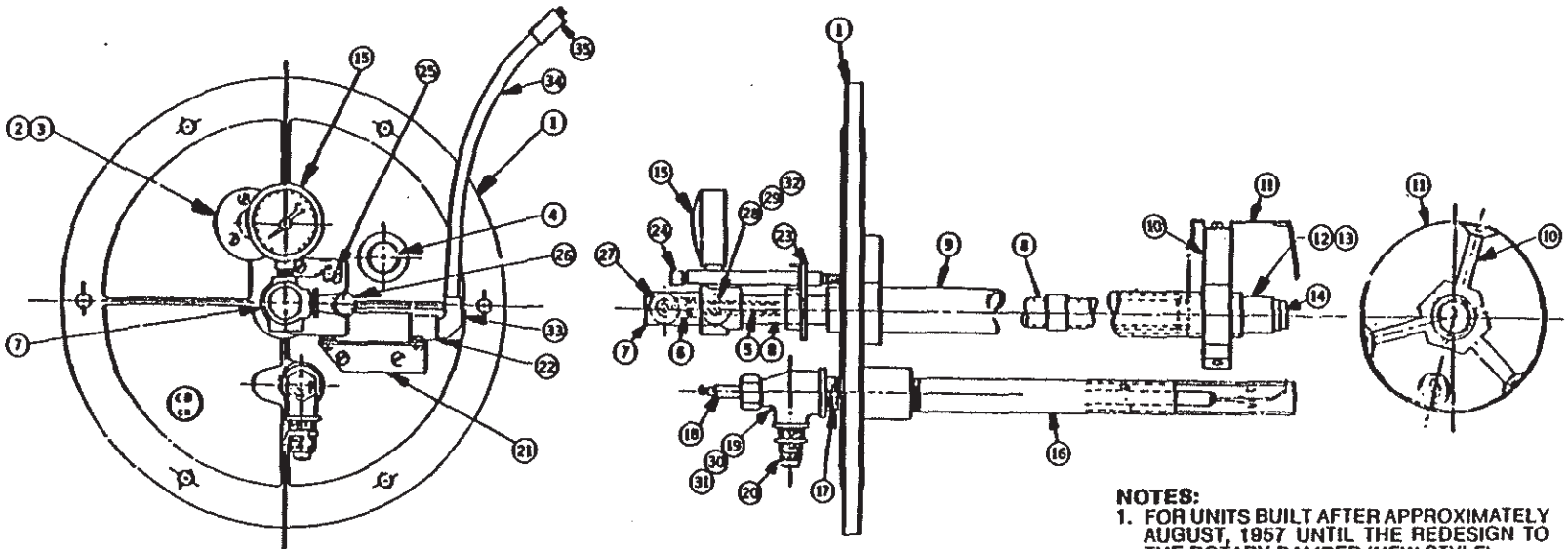

- NOTES:**
1. FOR UNITS BUILT AFTER APPROXIMATELY AUGUST, 1957 UNTIL THE REDESIGN TO THE ROTARY DAMPER (NEW STYLE).
 2. THE BURNER DRAWER ASSEMBLY PART NUMBER 429-251 WHICH COVERED ALL BOILER SIZES WAS OBSOLETE AND NEW NUMBERS TAKEN OUT FOR EACH SIZE.

DATE
4/1/86

OIL BURNER DRAWER WITH GAS PILOT
CB50-100 HORSEPOWER
OLD STYLE

REVISION NO. 0 SHEET 16 REFERENCE NO. FT5.1.4

THIS INFORMATION IS CONFIDENTIAL AND IS NOT TO BE USED IN ANY WAY DETRIMENTAL TO THE COMPANY'S INTERESTS.

ITEM	REQ	PART NO.	DESCRIPTION
1	1	59-168	BURNER BACK PLATE (CASTED)
2	1	851-77	MICA SIGHT HOLE - 1 1/2"
3	1	85-11	SIGHT HOLE RETAINER
4	1	SEE TABLE	DIFFUSER - NOT SHOWN
5	1	857-151	NIPPLE
6	1	57-21	GAS PILOT PIPE
7	1	857-175	NIPPLE
8	1	284-8	TEE
9	1	845-312	ADAPTER
10	1	435-11	IGNITION ELECTRODE
11	1	904-38	RUBBER GROMMET
*	1	429-202	BURNER DRAWER ASSEMBLY

ITEM 4 - TABLE	
CB-50	275-65
CB-60	275-66
CB-70	275-67
CB-80	275-68
CB-100	275-74

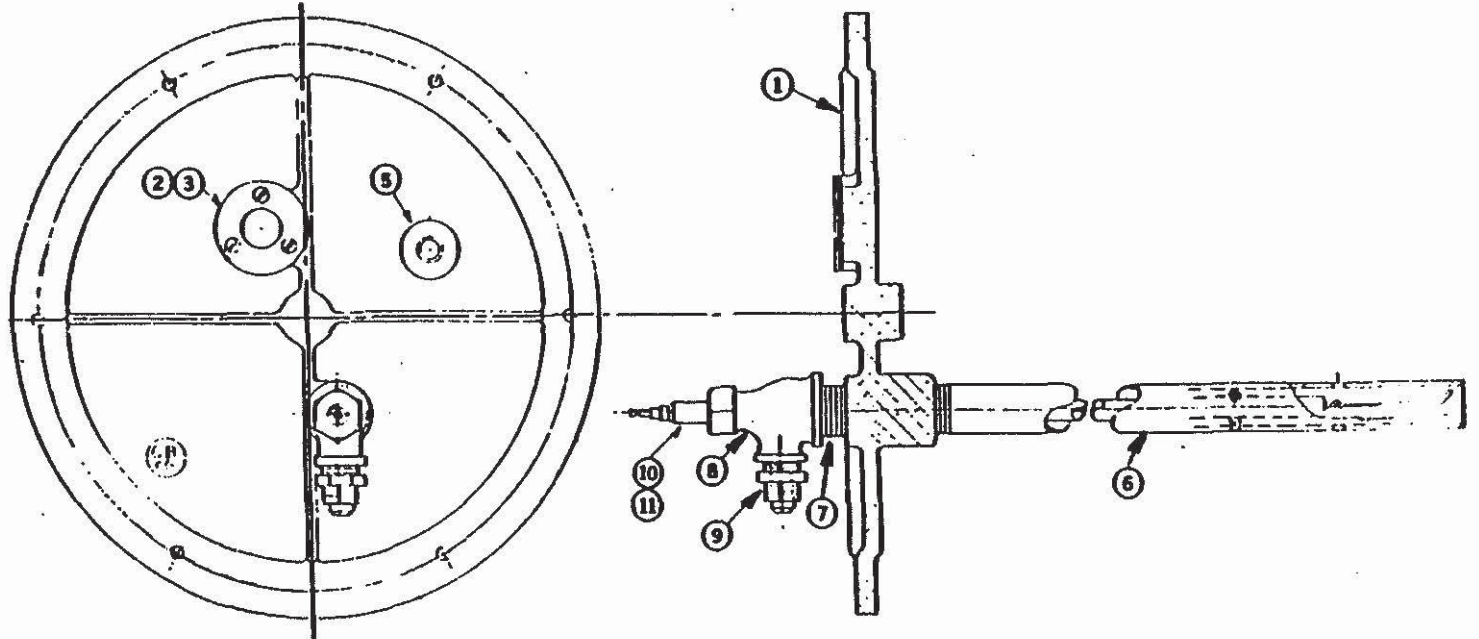

NOTE:
 FOR UNITS BUILT PRIOR TO APPROXIMATELY AUGUST 1957.
 AFTERWARDS 429-202 WAS SUPERSEDED BY 429-253.

CleaverBrooks
 DIVISION OF AQUA-CHEM, INC.
 MILWAUKEE WISCONSIN 53201
PARTS REFERENCE

DATE
 4/1/86

**GAS BURNER DRAWER
 CB50-100 HORSEPOWER
 OLD STYLE**

REVISION NO. 0 SHEET NO. 11 OF 16 REFERENCE NO. FTS.1.4

THIS INFORMATION IS CONFIDENTIAL AND IS NOT TO BE USED IN ANY WAY UNFAVORABLE TO THE COMPANY'S INTERESTS.

ITEM	REQ	PART NO.	DESCRIPTION
1	1	SEE TABLE	BURNER BACK PLATE (CASTED)
2	1	851-77	MICA SIGHT HOLE - 1 1/2"
3	1	65-11	SIGHT HOLE RETAINER
4	1	857-151	NIPPLE
5	1	158-42	GUN PLUG
6	1	90-139	BURNER DRAWER TUBE
7	1	134-48	SPIDER
8	1	SEE TABLE	GAS PILOT PIPE
9	1	857-175	NIPPLE
10	1	435-11	IGNITION ELECTRODE
11	1	284-8	TEE
12	1	845-312	ADAPTER - STRAIGHT
13	1	SEE TABLE	DIFFUSER
14	1	904-38	RUBBER GROMMET
*	1	SEE TABLE	BURNER DRAWER ASSEMBLY

TABLE						
ITEM	CB50	CB60	CB70	CB80	CB100	CB125A
1	59-877					59-1270
8	57-21					57-143
13	275-65	275-66	275-67	275-68	275-69	275-132
*	429-253					429-373

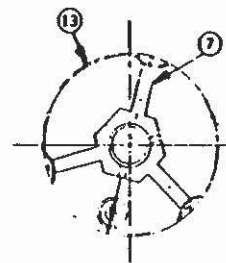
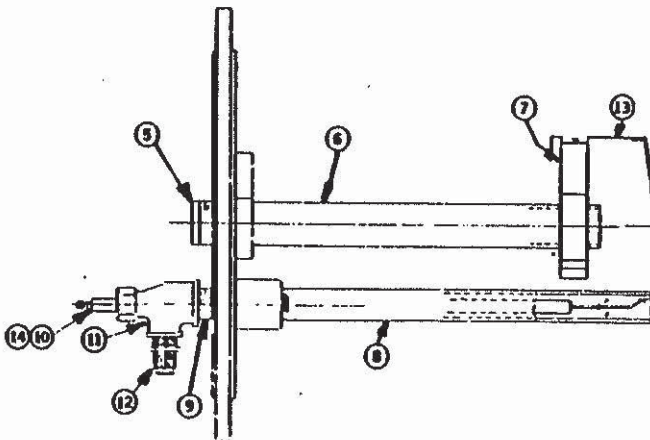
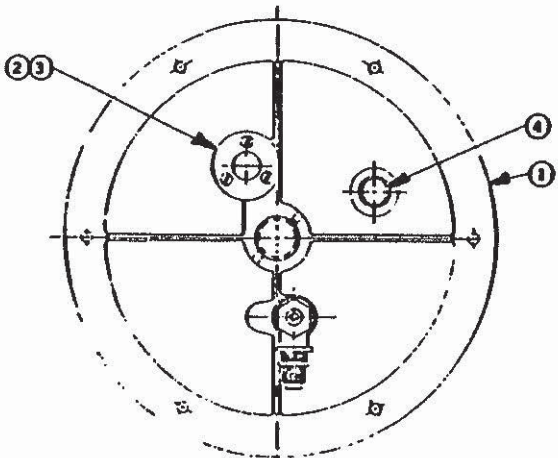

NOTE:
 FOR UNITS BUILT AFTER APPROXIMATELY AUGUST 1957
 UNTIL THE REDESIGN TO THE ROTARY DAMPER (NEW STYLE).

Cleaver

Brooks

DIVISION OF AQUA-CHEM INC

MILWAUKEE, WISCONSIN 53201

PARTS REFERENCE

DATE

4/1/86

**GAS BURNER DRAWER
 CB50-100 HORSEPOWER
 OLD STYLE**

REVISION NO.

0

SHEET

NO. 12 OF 16

REFERENCE NO.

FTS.1.4

THIS INFORMATION IS CONFIDENTIAL AND IS NOT TO BE USED IN ANY WAY DETRIMENTAL TO THE COMPANY'S INTERESTS.

Cleaver-Brooks

DIVISION OF AQUA-CHEM, INC.

MILWAUKEE, WISCONSIN 53201

PARTS REFERENCE

ITEM	REQ	PART NO.	DESCRIPTION	ITEM	REQ	PART NO.	DESCRIPTION
1	1	SEE TABLE	BURNER BACK PLATE WITH BEARING	22	2	435-38	IGNITION ELECTRODE
2	1	108-47	ROTARY DAMPER	23	2	924-49	EXTENSION SPRING (SPECIFY LENGTH)
3	1	851-77	MICA SIGHT HOLE - 1-1/2"	24	1	827-6	CONDUIT - 12" LG. (SPECIFY LENGTH)
4	1	66-11	SIGHT HOLE RETAINER	25	1	836-89	LIMIT SWITCH
5	1	6-4	BEARING	26	1	8-710	LIMIT SWITCH BRACKET
6	1	32-497	SCANNER TUBE GASKET	27	1	251-7	NOZZLE TIP AND SWIRLER - PILOT
7	1	90-795	SCANNER TUBE ASSEMBLY	28	1	82-34	SWIRLER SPRING - PILOT
8	3	SEE TABLE	SCREEN SPACER	29	1	2-31	DAMPER ARM
9	1	SEE TABLE	DIFFUSER	30	1	848-3	CONNECTOR
10	1	90-787	BURNER DRAWER TUBE	31	1	277-23	NOZZLE BODY - PILOT
11	1	SEE TABLE	SPIDER	32	1	SEE TABLE	ELECTRODE BRACKET
12	1	SEE TABLE	DIFFUSER SCREEN	33	1	940-526	BALL CHECK VALVE
13	2	848-100	FIBER BUSHING	34	1	108-10	OIL ORIFICE BLOCK
14	1	73-28	SEAL RING	35	1	848-16	CONNECTOR
15	1	845-308	ELBOW - 1/8"	36	1	899-23	NOZZLE WITH STRAINER
16	2	845-42	ELBOW - FLARED	37	1	847-718	REDUCER COUPLING
17	3	845-329	CONNECTOR	38	1	847-416	REDUCER BUSHING
18	2	939-60	TUBING - 12" LG. (SPECIFY LENGTH)	*	1	SEE TABLE	BURNER DRAWER ASSEMBLY
19	2	84-179	FEED THRU INSULATOR				
20	1	58-21	LOCKING PIN				
21	1	869-38	NUT				

NOTES: 1.) FOR BURNER GUN AND PARTS SEE SECTION FT5.2.1

ITEM	TABLE		
	CB50-60	CB70-80	CB100 & 125A
1	59-2654	59-2654	59-2653
8	77-383	77-384	—
9	275-186	275-187	275-185
11	134-73	134-73	134-47
12	72-33	72-33	—
32	8-577	8-577	8-333
*	429-363	429-364	429-365

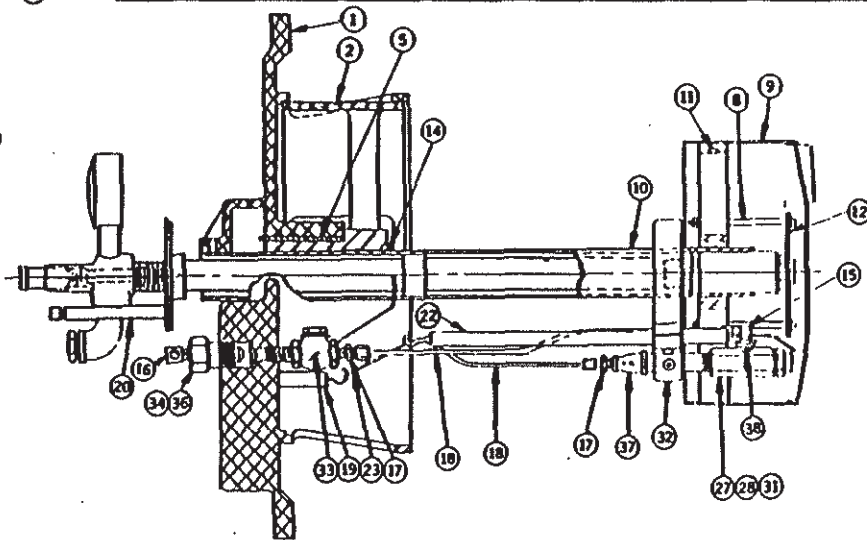
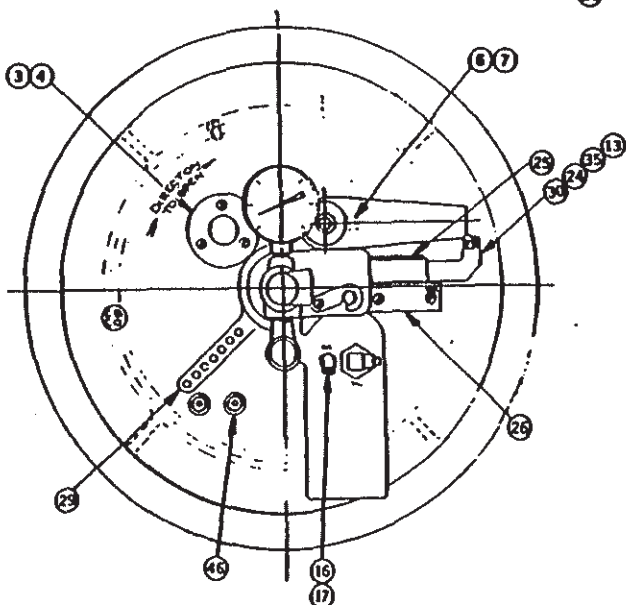

BURNER DRAWER WITH OIL PILOT
CB50-100 HORSEPOWER
NEW STYLE

DATE
4/1/86

REVISION NO. 0
 SHEET No. 13 of 16
 REFERENCE NO. FT5.1.4

THIS INFORMATION IS CONFIDENTIAL AND IS NOT TO BE USED IN ANY WAY DETRIMENTAL TO THE COMPANY'S INTERESTS.

Cleaver-Brooks

DIVISION OF AQUA-CHEM, INC.

MILWAUKEE, WISCONSIN 53201

PARTS REFERENCE

DATE
4/1/86

BURNER DRAWER WITH GAS PILOT
CB50-100 HORSEPOWER
NEW STYLE

REVISION NO. 0
SHEET No. 14 of 16
REFERENCE NO. FT5.1.4

ITEM	REQ	PART NO.	DESCRIPTION	ITEM	REQ	PART NO.	DESCRIPTION
1	1	SEE TABLE	BURNER BACKPLATE WITH BEARING	19	1	853-1	O-RING
2	1	108-47	ROTARY DAMPER	20	1	58-21	LOCKING PIN
3	1	851-77	MICA SIGHT HOLE - 1-1/2"	21	1	869-36	NUT
4	1	65-11	SIGHT HOLE RETAINER	22	1	34-7	IGNITION ELECTRODE GLAND
5	1	6-4	BEARING	23	1	SEE TABLE	GAS PILOT ADAPTER
6	3	SEE TABLE	SCREEN SPACER	24	1	827-6	CONDUIT 12" LG. (SPECIFY LENGTH)
7	1	SEE TABLE	DIFFUSER SCREEN	25	1	845-194	ELBOW
8	1	32-497	SCANNER TUBE GASKET	26	1	90-919	GAS PILOT PIPE
9	1	SEE TABLE	DIFFUSER	27	1	825-30	GAS COCK
10	1	90-787	BURNER DRAWER TUBE	28	1	90-795	SCANNER TUBE ASSEMBLY
11	1	SEE TABLE	SPIDER	29	1	435-38	IGNITION ELECTRODE
12	1	SEE TABLE	STABILIZER	30	1	836-89	LIMIT SWITCH
13	1	134-53	ELECTRODE HOLDER	31	1	8-710	LIMIT SWITCH BRACKET
14	1	848-3	CONNECTOR	32	1	73-28	SEAL RING
15	2	848-100	FIBER BUSHING	33	1	SEE TABLE	SEAL RING FOR P/N 1-197 (NOT SHOWN)
16	1	286-5	ADAPTER GAS PILOT PIPE	34	1	2-31	DAMPER ARM
17	1	858-310	ACCESS PLUG	35	1	848-18	CONNECTOR
18	1	48-98	VENTURI - ASPIRATOR	*	1	SEE TABLE	BURNER DRAWER ASSEMBLY

- NOTES: 1.) FOR BURNER GUN AND PARTS SEE SECTION FT5.2.1
 2.) FOR BURNER DRAWER ASSEMBLY PART NO. 429-722 USE PART NO. 429-698.
 3.) FOR BURNER DRAWER ASSEMBLY PART NO. 429-724 USE PART NO. 429-723.
 4.) FOR BURNER DRAWER ASSEMBLY PART NO. 429-725 USE PART NO. 429.699.

ITEM	TABLE		
	CB50 & 60	CB70 & 80	CB100, 100A & 125A
1	59-2534	59-2534	59-2523
6	77-363	77-364	—
7	72-33	72-33	—
9	275-186	275-187	275-185
11	134-73	134-73	134-47
12	97-71	97-71	275-188
23	1-168	1-168	1-197
33	—	—	73-32
*	429-698	429-723	429-699

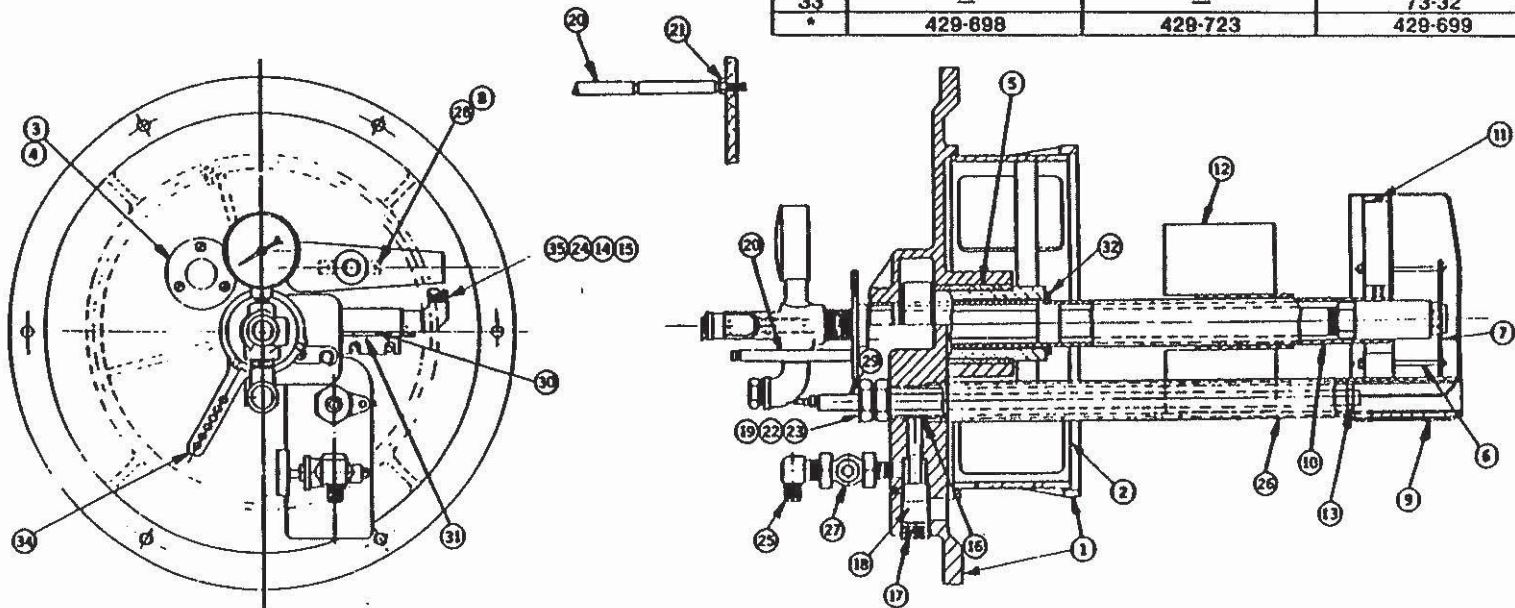

THIS INFORMATION IS CONFIDENTIAL AND IS NOT TO BE USED IN ANY WAY DETRIMENTAL TO THE COMPANY'S INTERESTS.

Cleaver-Brooks

DIVISION OF AQUA-CHEM, INC.

MILWAUKEE, WISCONSIN 53201

PARTS REFERENCE

ITEM	REQ	PART NO.	DESCRIPTION	ITEM	REQ	PART NO.	DESCRIPTION
1	1	SEE TABLE	SPIDER	16	1	SEE TABLE	GAS PILOT ADAPTER
2	1	SEE TABLE	DIFFUSER SCREEN	18	1	34-7	IGNITION ELECTRODE GLAND
3	1	851-77	MICA SIGHT HOLE - 1-1/2"	17	1	853-1	O-RING
4	1	65-11	SIGHT HOLE RETAINER	18	1	845-194	ELBOW
5	1	2-31	DAMPER ARM	19	1	825-30	GAS COCK
6	3	SEE TABLE	SCREEN SPACER	20	1	6-4	BEARING
7	1	SEE TABLE	DIFFUSER	21	1	48-98	VENTURI - ASPIRATOR
8	1	90-785	SCANNER TUBE ASSEMBLY	22	1	858-310	ACCESS PLUG
9	1	32-497	SCANNER TUBE GASKET	23	1	286-5	ADAPTER GAS PILOT PIPE
10	1	134-53	ELECTRODE HOLDER	24	1	SEE TABLE	BURNER BACKPLATE WITH BEARING
11	1	90-787	BURNER DRAWER TUBE	25	1	108-47	ROTARY DAMPER
12	1	90-913	GAS PILOT PIPE	26	1	73-28	SEAL RING
13	1	158-42	GUN PLUG	27	1	SEE TABLE	STABILIZER
14	1	435-38	IGNITION ELECTRODE	28	1	SEE TABLE	SEAL RING FOR PIN 1-197 (NOT SHOWN)
				*	1	SEE TABLE	GAS BURNER DRAWER ASSEMBLY

TABLE			
ITEM	CB50 & 60	CB70 & 80	CB100 & 125A
1	134-73	134-73	134-47
2	72-33	72-33	—
6	77-383	77-384	—
7	275-188	275-187	275-185
15	1-168	1-168	1-197
24	59-2534	59-2534	59-2523
27	97-71	97-71	275-188
28	—	—	73-32
*	429-727	429-789	429-728

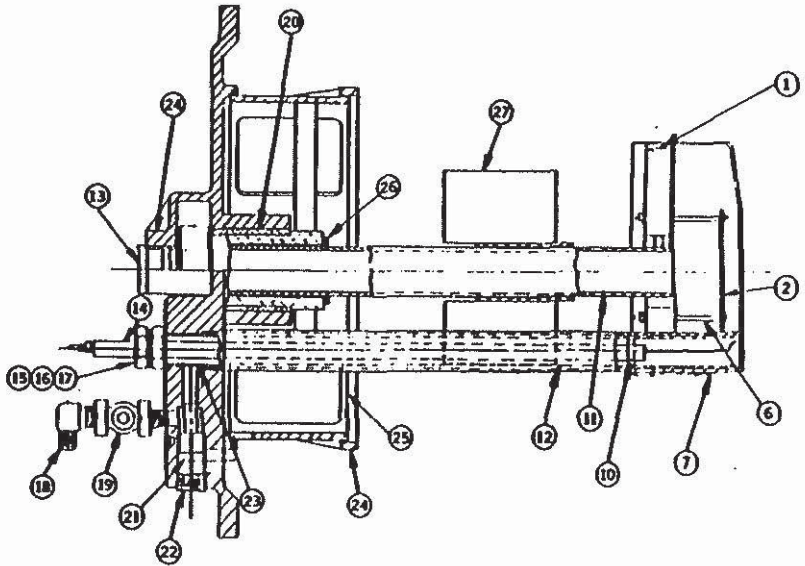
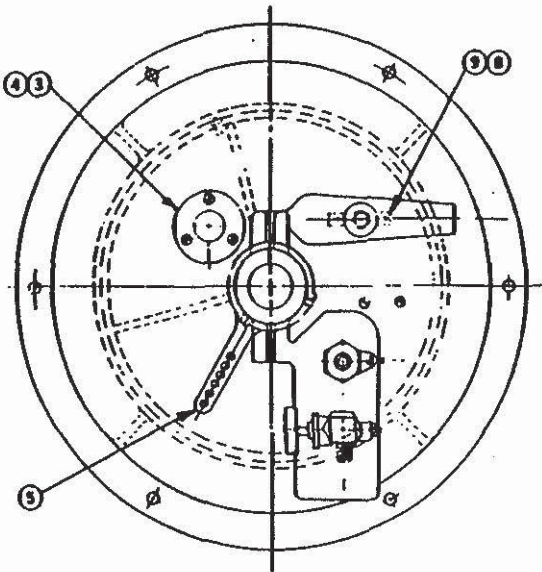

THIS INFORMATION IS CONFIDENTIAL AND IS NOT TO BE USED IN ANY WAY DETRIMENTAL TO THE COMPANY'S INTERESTS.

DATE
4/1/86

GAS BURNER DRAWER
CB50-100 HORSEPOWER
NEW STYLE

REVISION NO. 0 SHEET 15 OF 16 REFERENCE NO. FT5.1.4

PARTS REFERENCE

MILWAUKEE, WISCONSIN 53201
DIVISION OF AQUA-CHEM, INC.

Cleaver-Brooks

DATE
4/1/86

BURNER DRAWER WITH DUAL PILOT
NEW STYLE

ITEM	REQ	PART NO.	DESCRIPTION	ITEM	REQ	PART NO.	DESCRIPTION
1	1	626-2995	BURNER BACKPLATE WITH BEARING	28	1	858-310	ACCESS PLUG
2	1	108-47	ROTARY DAMPER	29	1	2-31	DAMPER ARM
3	1	851-77	MICA SIGHT HOLE - 1-1/2"	30	1	848-3	CONNECTOR
4	1	66-11	SIGHT HOLE RETAINER	31	1	8-2581	ELECTRODE BRACKET
5	1	6-4	BEARING	32	1	90-913	GAS PILOT PIPE
6	1	847-417	REDUCER BUSHING	33	1	940-526	BALL CHECK VALVE
7	2	845-329	CONNECTOR	34	1	134-53	ELECTRODE HOLDER
8	1	847-418	REDUCER BUSHING	35	1	848-18	CONNECTOR
9	1	SEE TABLE	DIFFUSER	36	3	77-363	SCREEN SPACER
10	1	90-787	BURNER DRAWER TUBE	37	1	847-525	REDUCER COUPLING
11	1	626-2997	SPIDER	38	1	847-415	REDUCER BUSHING
12	1	847-545	REDUCER ELBOW	39	1	277-23	NOZZLE BODY - PILOT
13	1	108-10	OIL ORIFICE BLOCK	40	1	82-34	SWIRLER SPRING - PILOT
14	1	845-42	ELBOW-FLARED	41	1	251-7	NOZZLE TIP AND SWIRLER - PILOT
15	1	626-2998	DIFFUSER SCREEN	42	1	827-6	CONDUIT - 12" LG. (SPECIFY LENGTH)
16	1	845-313	ELBOW	43	1	699-29	NOZZLE WITH STRAINER
17	1	288-5	ADAPTER GAS PILOT PIPE	44	1	32-497	SCANNER TUBE GASKET
18	1	853-1	O-RING	45	2	626-2797	IGNITION ELECTRODE - OIL PILOT
19	1	34-7	IGNITION ELECTRODE GLAND	46	2	94-179	FEED THRU INSULATOR
20	1	58-21	LOCKING PIN	47	1	939-60	TUBING - 20" LG. (SPECIFY LENGTH)
21	1	889-38	NUT	48	1	939-60	TUBING - 24" LG. (SPECIFY LENGTH)
22	1	48-98	VENTURI - ASPIRATOR	49	1	108-64	OIL TERMINAL BLOCK
23	1	435-38	IGNITION ELECTRODE - GAS PILOT	50	1	90-795	SCANNER TUBE ASSEMBLY
24	2	292-150	IGNITION CABLE	51	1	97-71	STABILIZER
25	1	838-89	LIMIT SWITCH	52	2	845-306	ELBOW
26	1	8-710	LIMIT SWITCH BRACKET	53	2	848-100	FIBER BUSHING
27	1	825-30	GAS COCK	54	1	73-28	SEAL RING
				*	1	SEE TABLE	BURNER DRAWER ASSEMBLY

NOTES: 1.) FOR BURNER GUN AND PARTS SEE SECTION FT5.2.1

TABLE		
ITEM	CB60-80	CB70-80
9	275-231	275-230
*	428-1053	428-1054

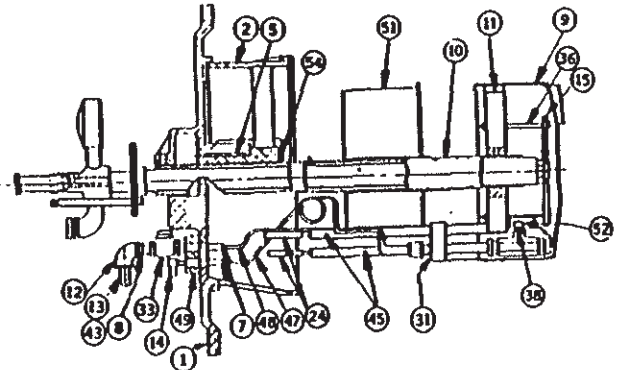
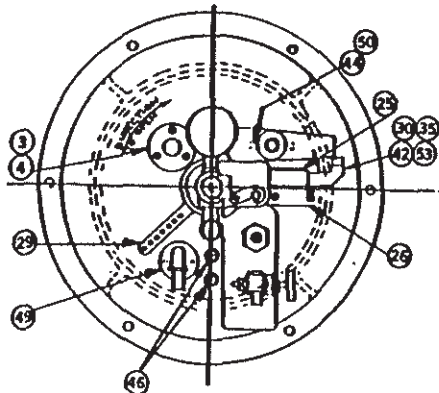
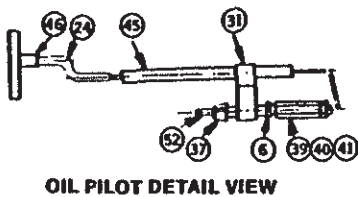
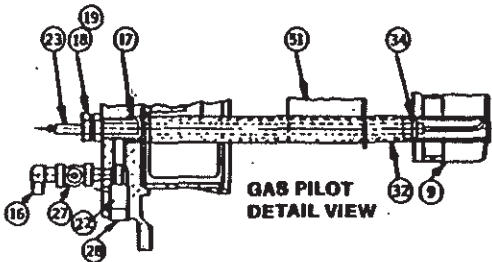

THIS INFORMATION IS CONFIDENTIAL AND IS NOT TO BE USED IN ANY WAY DETRIMENTAL TO THE COMPANY'S INTERESTS.

REVISION NO. 0
SHEET NO. 16 OF 16
REFERENCE NO. FT5.1.4

Cleaver-Brooks

DIVISION OF AGUA-CHEM, INC.

MILWAUKEE, WISCONSIN 53201

PARTS REFERENCE

ITEM	REQ	PART NO.	DESCRIPTION	ITEM	REQ	PART NO.	DESCRIPTION
1	1	SEE TABLE	DIFFUSER	22	2	94-179	FEED THRU INSULATOR
2	1	108-47	ROTARY DAMPER	23	1	939-60	TUBING 10 - 1/2" LG. (SPECIFY LG.)
3	1	851-77	MICA SIGHT HOLE - 1-1/2"	24	1	848-16	CONNECTOR
4	1	65-11	SIGHT HOLE RETAINER	25	1	939-60	TUBING 12" LG. (SPECIFY LG.)
5	1	845-308	ELBOW - 1/8"	28	1	836-89	LIMIT SWITCH
6	1	73-26	SEAL RING	27	1	8-710	LIMIT SWITCH BRACKET
7	1	848-2	CONNECTOR	28	3	845-329	FITTING - 1/8"
8	1	847-718	REDUCER COUPLING	29	1	SEE TABLE	NOZZLE WITH STRAINER
9	1	59-917	BURNER BACKPLATE WITH BEARING	30	1	11-10	DAMPER STOP
10	1	90-149	BURNER DRAWER TUBE	31	1	2-31	DAMPER ARM
11	1	134-47	SPIDER	32	1	6-4	BEARING
12	1	847-415	REDUCER BUSHING	33	1	8-709	INDICATOR STOP BRACKET
13	1	277-23	NOZZLE BODY - PILOT	34	1	22-122	STABILIZER
14	1	82-34	SWIRLER SPRING - PILOT	35	1	8-333	ELECTRODE BRACKET
15	1	251-7	NOZZLE TIP & SWIRLER - PILOT	36	1	940-528	BALL CHECK VALVE
16	1	845-429	FITTING	37	1	108-10	OIL ORIFICE BLOCK
17	1	845-42	ELBOW - FLARED	38	2	848-100	FIBER BUSHING
18	2	924-49	EXTENSION SPRING (SPECIFY LG.)	*	1	SEE TABLE	BURNER DRAWER ASSEMBLY
19	2	435-38	IGNITION ELECTRODE				
20	1	58-21	LOCKING PIN				
21	1	869-36	NUT				

NOTES: 1.) FOR BURNER GUN AND PARTS
SEE SECTION FT5.2.1

TABLE				
ITEM	CB125 & 160	CB125S & 160S	CB175S	CB175A & 200
1	275-83	275-83	275-83	275-82
28	899-23	899-28	899-80	899-80
*	429-283	429-791	429-800	429-257

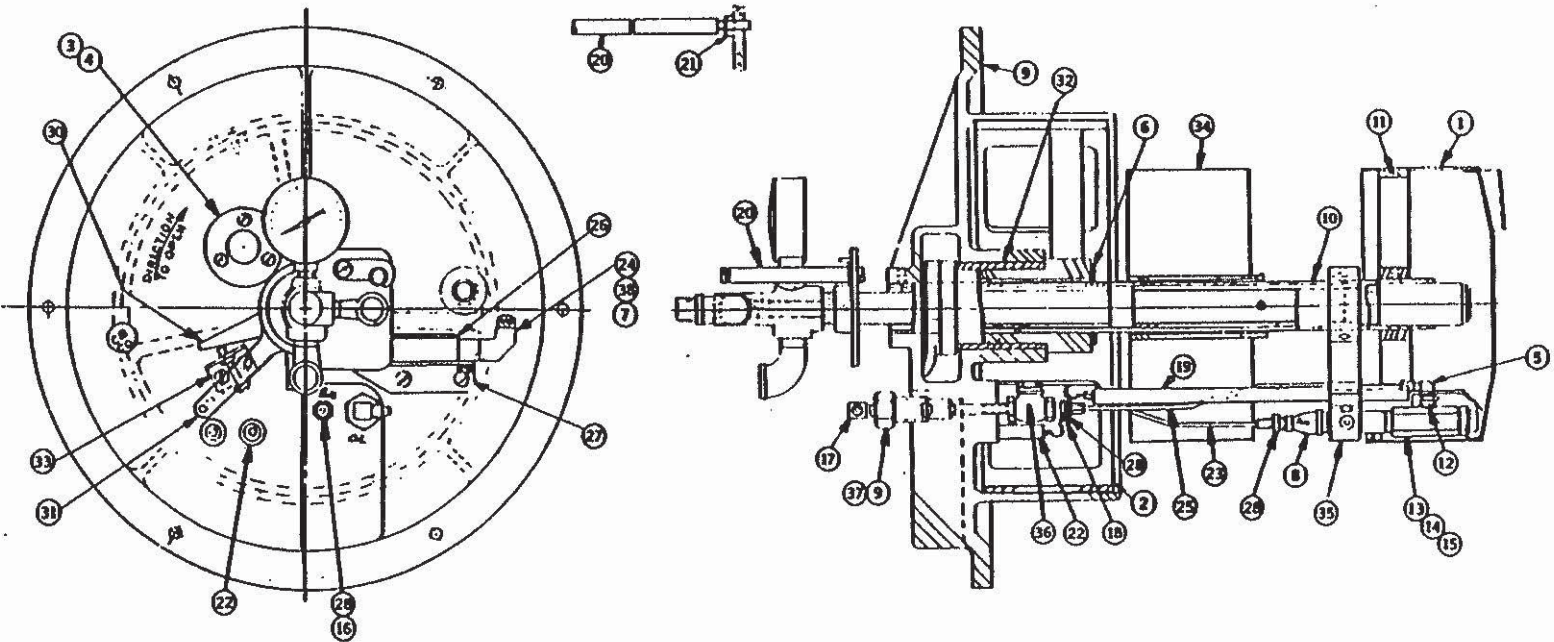

DATE
4/1/86

BURNER DRAWER WITH
LIGHT OIL PILOT

CB125-200 HORSEPOWER

REVISION NO. SHEET REFERENCE NO.

0

No. 1 of 4

FT5.1.5

THIS INFORMATION IS CONFIDENTIAL AND IS NOT TO BE USED IN ANY WAY DETRIMENTAL TO THE COMPANY'S INTERESTS.