

BILL OF MATERIAL

ITEM	PART #	QTY.	DESCRIPTION	MATERIAL	DWG. #
1	EA100S-2	1	BODY	CAST STEEL A216 GR. WCB	B-11878
2	EA100EP-2	1	SWITCH COVER	CAST IRON	B-9573
3	EA100-12	1	CONNECTOR ROD ASSEMBLY	STAINLESS STEEL A276	B-8838
4	EA100-13	1	MAGNET ASSEMBLY	-	B-8838
5	EA100-14X	1	SWITCH ASSEMBLY	-	B-8838
6	EA100EPS-2	1	SWITCH HOUSING ASSEMBLY	CAST STEEL A216 GR. WCB	A-9698
7	EA100-21	1	LEVER PIN	STAINLESS STEEL A276	B-8838
8	EA100-17	1	NAME PLATE	ALUMINUM	B-25-59
9	X173260	2	#4 X 3/16 SHEET METAL SCREW	STEEL	-
10	X171700	2	COTTER PIN 1/32 X 1/2	STAINLESS STEEL 18-8	-
11	C1-3	1	GASKET	STEEL	-
12	X173720	6	STUD 1/2-13 X 3	STEEL A193 GR.7	-
13	F3S	1	FLDPT	STAINLESS STEEL A269	A-5665
14	EA6-15	1	SWITCH INSULATOR	FIBRE	A-7577
15	X174280	2	SHAKEPRODF #6 LOCK WASHER	-	-
16	X172860	2	R.H. SCREW & NUT 6-32 X 1	BRASS	-
17	X171501	12	HEAVY HEX NUT 1/2-13	STEEL	-

NOTES: MICRO SWITCH, TYPE BZ-2RW82444-2A
 UNDERWRITER APPROVED
 FOR THE FOLLOWING RATINGS:
 5A-125,250, DR 480V AC
 1-1/2A- 24V DC
 1/2A-125V DC
 1/4A-250V DC

HYDROSTATIC TEST 1200 PSI

STATIONARY SERVICE RATING
 MAX PRESSURE:
 800 PSI @ 520°F

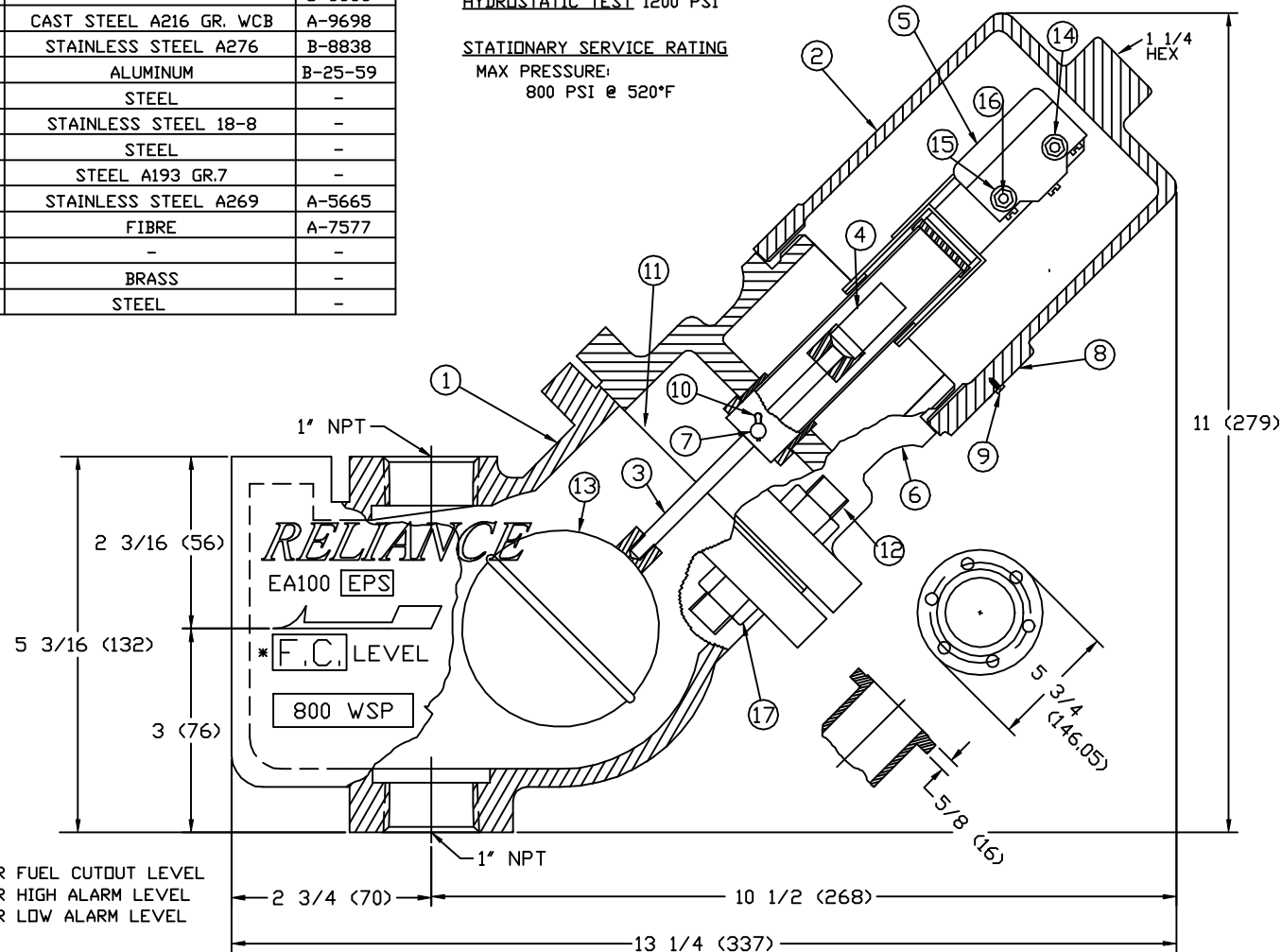
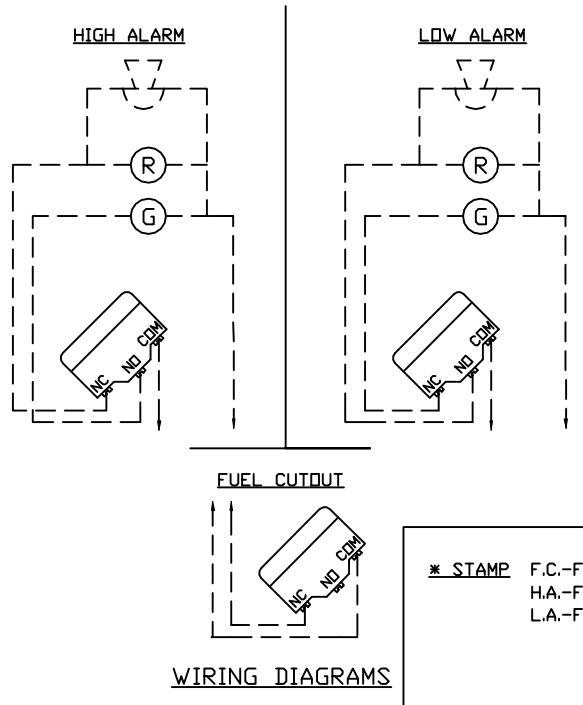

* STAMP F.C.-FOR FUEL CUTOFF LEVEL
 H.A.-FOR HIGH ALARM LEVEL
 L.A.-FOR LOW ALARM LEVEL

* TOLERANCES DEFINED BY PES-004

MATERIAL: X
 DRAWN: SMH CHECKED: X
 SCALE: NONE DATE: 9/21/95
 REV. 6 PER CDC 95-127

CLARK-RELIANCE CORP.
 STRONGSVILLE, OHIO, U.S.A.

PART NO.: SEE CHART

EA100EPS LEVALARM
 ASSEMBLY
 TOLERANCE CLASS: X

DRAWING
 NUMBER:
 B-9574
 REV. 6