

# Levalarm® Gold™



---

**Reliance®**  
A PRODUCT OF CLARK-RELIANCE

## **STORAGE and HANDLING**

The Reliance® Levalarm® Gold™ meets or exceeds all applicable specifications when shipped from the factory.

All units should be inspected upon receipt to ensure that no damage has been incurred during transit. If there is a claim due to damage, it should be filed with the carrier immediately. Clark-Reliance® Boiler Trim products should be stored in a dry and sheltered area prior to installation. The equipment provided may consist of electrical items that are intended for either indoor or outdoor use. As a matter of good practice, dry storage will prevent the products from exposure to the outdoor elements. This will eliminate the potential for water damage. The temperature of the storage area should not exceed 150 Deg. F (84 Deg. C) or drop below 32 Deg. F (0 Deg. C).

## **OPERATION**

A stainless steel float is attached to the end of a rod with a stainless steel encapsulated magnet. The magnet travels vertically in the pressure tube. The primary magnet on the float rod inside the pressure tube drives the secondary magnet, which in turn drives the tertiary magnet. The tertiary magnet is mounted to the switch arm and activates the switch. See Figure 1. The use of repelling magnetic fields creates a positive interlocking switch that is both vibration resistant and compensates for installation misalignment. A buoyed float will cause the reaction of the magnets to hold the switch open or closed, depending on which terminals are used. As liquid falls in the chamber, the float drops and directs the magnets to the opposite position which activates the switch in the opposite direction.

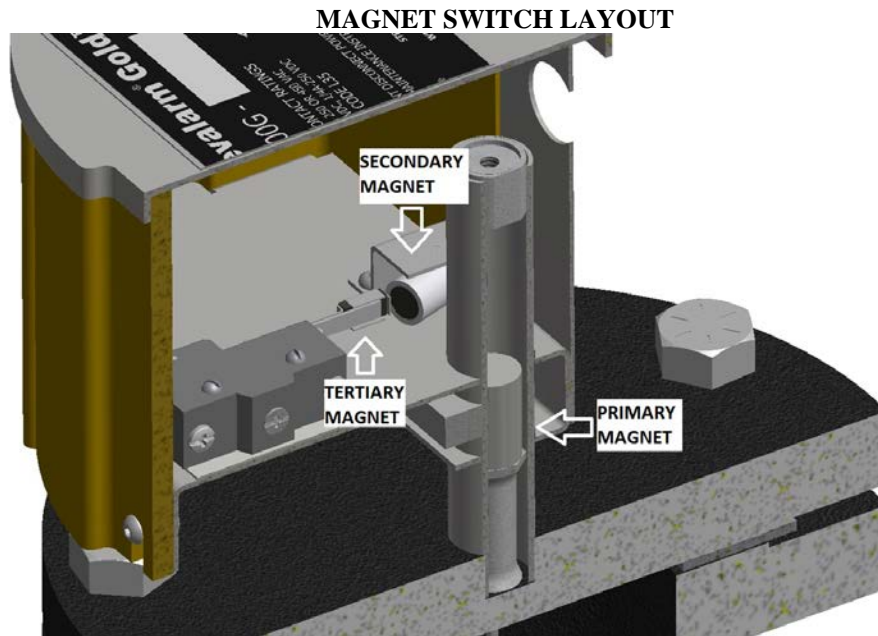

**FIGURE 1**

## **INSTALLATION**

**Caution:** Before proceeding, follow any and all plant lock out - tag out procedures required. Verify that all power is turned off to the Levalarm®s. If under pressure, the equipment should be isolated, or the boiler should be shut down before proceeding with the installation. Open drain valve to eliminate any trapped pressure. All inspection and installation steps should be performed by a qualified technician and should be executed in accordance with all applicable national and local codes

EA100G Series Levalarm® dimensional information is available upon request. Standard connections for the EA100G Series Levalarm®s are 1" FNPT for threaded connections or 1" FSW for socket weld connections. The Levalarm® should be installed with the reference arrow (switch point) at the level where the alarm or trip is specified. Shut off valves above and below the Levalarm® should be installed for safe inspection or repair of the unit. However, these valves must be locked open when the boiler is in service. Also, a drain connection with a shut off valve

**Reliance®**  
A PRODUCT OF CLARK-RELIANCE

should be installed to a point of safe discharge to facilitate blowdowns. Below in Figure 2 is a typical arrangement for the installation of the Levalarm®. Verify that installation conforms to local and national Codes and Standards. After the piping has been installed to the body of the Levalarm®, the switch should be connected by following this procedure:

1. Remove the switch cover in order to access the connections on the switch assembly by loosening the three button head cap screws on the outside of the gold housing, do not remove screws completely. Pull upward on gold housing to expose switch.
2. Use the ½” conduit opening in the switch housing assembly for connecting flexible or rigid conduit when wiring the unit.  
**CAUTION:** Make sure that all wire leads to the switch do not interfere with the action of the switch before replacing the switch cover!
3. Example wiring diagrams for connecting the low water cutout, alarms (such as lights or and audible signal), etc, are illustrated below:

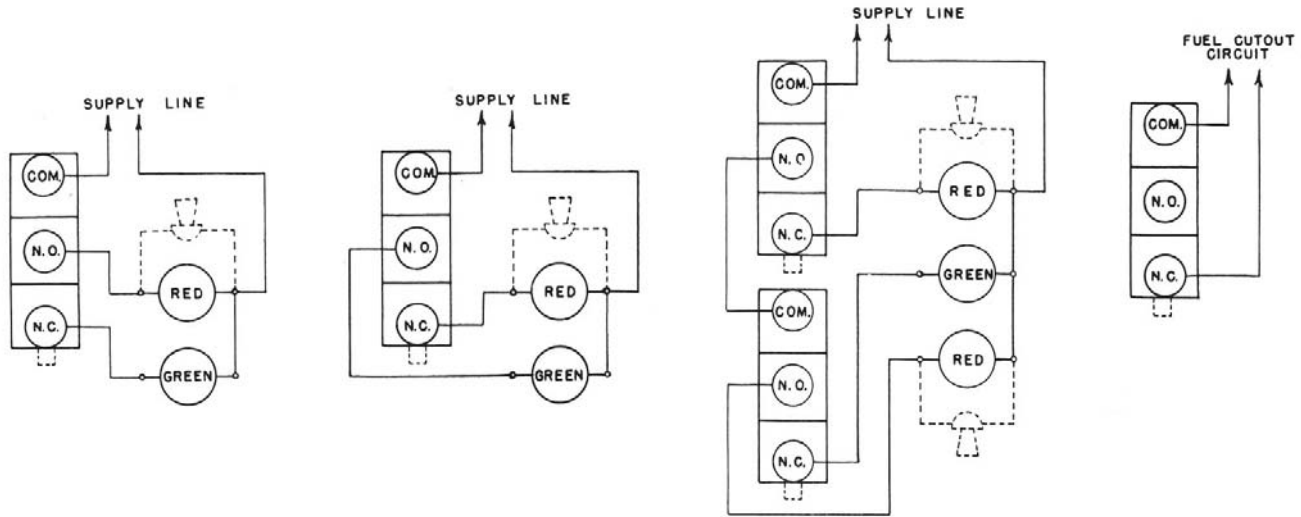

4. After checking that all connections are tight and correct, replace the switch cover, as the unit is now ready to be put in operation.

#### LEVALARM® LAYOUT

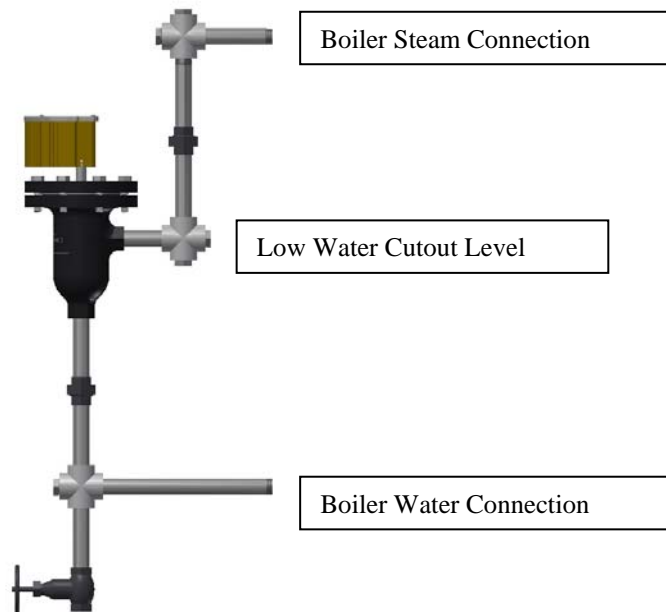

**Reliance®**  
 A PRODUCT OF CLARK-RELIANCE

**FIGURE 2**

**NOTE:** It is recommended that periodic inspection and routine maintenance be conducted to ensure that the Levalarm<sup>®</sup> continues to work properly. This can be conducted by following the procedure:

1. Isolate the Levalarm<sup>®</sup> by closing the steam and water isolation valves.
2. Disconnect power from Levalarm<sup>®</sup>.
3. Open the drain valve to drain the unit and relieve any internal pressure.
4. Disconnect the wiring and conduit.
5. Remove the switch housing to access all of the flange bolts.
6. Using a wrench or socket for the bolt and a wrench or socket for the nut, remove the nuts/bolts on the flanged cover. Discard old gasket.
7. Removing the flange provides complete access to the float and switch assembly. To remove the flange assembly pull straight up until float is clear from body.
8. Inspect the float to make sure that water has not leaked directly into the float.
9. Check to make sure the float and rod assembly freely moves up and down and does not stick or bind.
10. Reassemble the unit. Reinstall the Switch head assembly onto the body with a new gasket.
11. Lubricate the threads on the bolts with a high temperature nickel based lubricant. Torque the bolting in the proper sequence (see below in Figure 3) to required ft-lbs in 1/3rd increments found in the below chart.
12. Re-install the conduit and the wiring.
13. Verify proper function.

MODEL	1 <sup>st</sup> Torque	2 <sup>nd</sup> Torque	Final Torque
EA100G-150	33	66	100
EA100G-300/ EA100G-300SW	60	120	180
EA100G-600/ EA100G-600SW	116	233	350

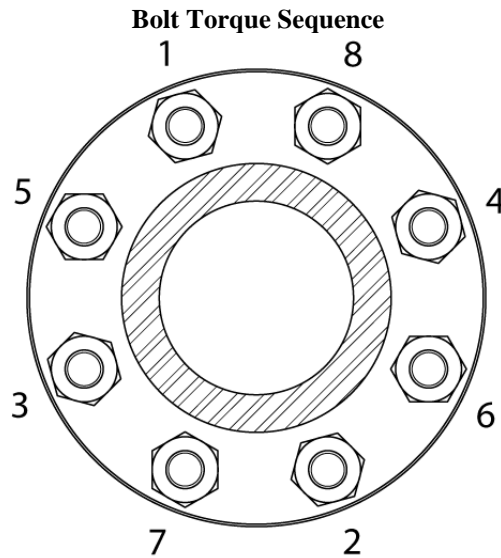

**Figure 3**

### **BLOW-DOWNS**

Note that the frequency and method of blow-down may affect service life and performance of the Levalarm<sup>®</sup>.

The connection lines to the Levalarm<sup>®</sup> can become restricted with sediment and indicate normal water levels when water may be low. After performing the blow-down procedure, if the water level does not appear to return to normal promptly, the connecting piping may be partially restricted and need to be cleaned.





**Clark-Reliance® suggests the following blow-down procedure:**

1. Close both the steam and water valves between the boiler drum and the Levalarm® unit.
2. Open the drain valve fully on the bottom of the Levalarm® piping.
3. Crack open the steam valve and allow a gentle rush of steam to pass through the device. The steam should not pass through for longer than 20 seconds.
4. Close the steam valve.
5. Blow-down the water line.
6. Close the blow-down valve and simultaneously open the steam and water valves, slowly bringing the equipment back to a normal operating level.
7. Water should enter the Levalarm® quickly when the blow-down valve is closed. This will indicate that the lines are free of sludge, sediment, or scale buildup.

**NOTE:**

1. Any trip or alarm circuits that are actuated by the equipment being blown-down should be bypassed to prevent false alarms during the blow-down process. A Clark-Reliance® Holding Switch model HS-0 or HS-1 can be used to by-pass the Low Water Cutout to prevent a false trip during the blow-down procedure.
2. Blow-down should be conducted on a weekly basis, or as necessary, based on water quality.

**SPECIFICATIONS**

Agency Approvals	UL 353  FM 7710 
Connection sizes:	EA100G-150: 1" FNPT EA100G-300/EA100G-300SW: 1" FNPT / 1" FSW EA100G-600/EA100G-600SW: 1" FNPT / 1" FSW
Pressure Rating:	EA100G-150: 200 PSI @ 388° F EA100G-300/EA100G-300SW: 570 PSI @ 483° F EA100G-600/EA100G-600SW: 1104 PSI @ 558° F
Float Switch Rating:	UL listed and CSA approved SPDT UL Code 35 5 A, 125, 250 or 480 Vac 1/2 A, 125 Vdc; 1/4 amp 250 Vdc Switch Max. Temperature: 400° F.
Environment:	Indoor or outdoor

**TROUBLESHOOTING THE EA100 SERIES LEVALARM®**

**Caution:** Before proceeding, follow any and all plant lock out - tag out procedures required. All installation steps should be performed by a qualified technician and should be executed in accordance with all applicable national and local codes.

Symptom	Probable Cause
1) Float is stuck in the "up" position"	a) Contamination on Switch Magnet Action
	b) Water Trapped in Unit
	c) Sediment / Contamination in Chamber

Possible remedies:

1. Conduct a blow-down, to ensure there is no water trapped in the unit.
2. Inspect the internal portion of the Levalarm® Chamber
  - a. Isolate the Levalarm® and make sure there is no pressure in the unit.
  - b. Remove the flange head assembly
  - c. Examine inside the flange assembly to make sure there is no debris trapped inside the device.



- d. Examine the drain path to make sure water has a clear drain path.
  - e. Inspect magnets on the action of the switch to make sure no debris have stopped the action.
3. Test the unit for proper functioning
    - a. To test the switch assembly, set the unit in a vise and make sure that the switch housing is vertical as if it were mounted on the boiler piping.
    - b. Attach an ohm meter to the common and normally open switch contact and manually move the float up and down and verify the switch operates on both directions. The meter should indicate continuity only when the switch is operated in the closed position.
    - c. Then, move the ohm meter terminal from the normally open terminal to the normally closed terminal and repeat the test. The meter should indicate an open circuit only when the switch is in the open position.
  4. If the unit fails to test properly, contact Clark-Reliance® for further instructions to adjust the switch mechanism or to obtain authorization to return the unit for factory inspection. If the switch tests OK, return unit to service.
  5. Reassemble the unit. Reinstall the Switch head assembly onto the body with a new gasket. Lubricate the bolts with a Nickel based high temperature lubricant and torque to requirements in the Installation section.
  6. Verify proper function.

Symptom	Probable Cause
2) Float is stuck in the “down” position”	a) Float encased in contamination
	b) Failed float
	c) Contaminants in Pressure Tube.

Possible remedies:

1. Inspect the internal portion of the Levalarm® Chamber
  - a. Isolate the Levalarm® and make sure there is no pressure in the unit.
  - b. Remove the flange head assembly
  - c. Remove, inspect the float assembly.
  - d. If the float contains water or shows signs of obvious damage, such as collapse or a crack near the spud where the float rod attaches, replace the float and use Loctite or equal on the threads of the float and float rod with a lock washer. Tighten the new float securely onto the float rod.
2. Test the unit for proper functioning
  - a. To test the switch assembly, set the unit in a vise and make sure that the switch housing is vertical as if it were mounted on the boiler piping.
  - b. Attach an ohm meter to the common and normally open switch contact and manually move the float up and down and verify the switch operates on both directions. The meter should indicate continuity only when the switch is operated in the closed position.
  - c. Then, move the ohm meter terminal from the normally open terminal to the normally closed terminal and repeat the test. The meter should indicate an open circuit only when the switch is in the open position.
3. If the unit fails to test properly, contact Clark-Reliance® for further instructions to adjust the switch mechanism or to obtain authorization to return the unit for factory inspection.
4. Reassemble the unit. Reinstall the Switch head assembly onto the body with a new gasket and apply a Teflon based sealant to both sides of the gasket. Lubricate the bolts with a Nickel based high temperature lubricant and torque to requirements in the Installation section.



Symptom	Probable Cause
3) Float arm operates properly, but the switch does not change state.	a) The REA1351 switch is out of adjustment
	b) The REA1351 switch has failed

1. Test the REA1351 Microswitch
  - a. Isolate the Levalarm<sup>®</sup> and make sure there is no pressure in the unit.
  - b. Remove the flange head assembly
  - c. Remove the Switch cover
2. Test the unit for proper functioning
  - a. To test the switch assembly, set the head assembly in a vise and make sure that the switch housing is vertical as if it were mounted on the boiler piping.
  - b. Attach an ohm meter to the common and normally open switch contact and manually move the float up and down and verify the switch operates on both directions. The meter should indicate continuity only when the switch is operated in the closed position.
  - c. Then, move the ohm meter terminal from the normally open terminal to the normally closed terminal and repeat the test. The meter should indicate an open circuit only when the switch is in the open position.
3. If the unit fails to test properly, contact Clark-Reliance<sup>®</sup> for further instructions to adjust the switch mechanism or to obtain authorization to return the unit for factory inspection. If the switch tests OK, return unit to service.
4. Reassemble the unit. Reinstall the Switch head assembly onto the body with a new gasket and apply a Teflon based sealant to both sides of the gasket. Lubricate the bolts with a Nickel based high temperature lubricant and torque to requirements in the Installation section.

**Warning:** If this equipment is used in a manner not specified by Clark-Reliance<sup>®</sup>, the protection provided by the equipment may be impaired. Only replacement parts manufactured by Clark-Reliance<sup>®</sup> should be used to ensure safety and reliable operation.

The use of non-Clark-Reliance<sup>®</sup> parts will void the factory warranty and any agency approvals.

Order genuine Clark-Reliance<sup>®</sup> replacement parts at: <http://parts.clark-reliance.com> or contact your local Clark-Reliance<sup>®</sup> Representative.

Any additional questions should be directed to your local Clark-Reliance<sup>®</sup> Representative, or to the Factory: Phone: +1 (440) 572-1500 Fax: +1 (440) 238-8828





On-Line Parts - *DIRECT* - for Clark-Reliance® Products

**JERGUSON®**

**Reliance®**

**MAGNE-SONICS™**

**JACOBY-TARBOX®**



[www.clark-reliance.com/parts](http://www.clark-reliance.com/parts)

**Reliance®**  
A PRODUCT OF CLARK-RELIANCE