



Operation and maintenance manual
Burner models: GP-350 M - 450 M
Burner equipment: WDx00, FGR (UL)



Read these instructions carefully before installation, use, or maintenance

Contents

1 Introduction

1.1	Liability disclaimer.....	3
1.2	Safety precautions.....	3
1.3	Product overview.....	7
1.4	Flue gas recirculation (optional).....	9
1.5	Handling and storing.....	10

2 Technical data

2.1	Burner technical data.....	11
2.2	Other technical data and requirements.....	12
2.3	Burner control technical data.....	13
2.4	Servomotor technical data.....	15
2.5	Display and operating unit technical data.....	15
2.6	O ₂ module technical data (WD200).....	15
2.7	Oxygen sensor technical data (WD200).....	16
2.8	Flame detector technical data.....	16

3 Installation

3.1	Space requirements.....	18
3.2	Removing protective covers and lifting the burner.....	18
3.3	Installing burner.....	20
3.4	Combustion head and masonry dimensions.....	22
3.5	Gas valve selection table.....	24
3.6	Installing burner to gas supply line.....	24
3.7	Installing gas pressure regulating assembly.....	26
3.8	Changing the fuel type from natural gas to LPG.....	27
3.9	Installing FGR duct system.....	28
3.10	Electrical connections.....	30

4 Commissioning

4.1	First start-up.....	32
4.2	Adjusting combustion head (GP).....	34
4.3	Adjusting combustion air (GP-450 M).....	36
4.4	Adjusting combustion differential air pressure switch.....	37
4.5	Adjusting gas pressure switch.....	39
4.6	Setting gas pressure regulator SKP.....	40
4.7	Setting gas pressure regulator FRS.....	41
4.8	Measuring gas pressure.....	44
4.9	Operating and display unit menu.....	47
4.10	Adjusting operating and display unit settings.....	50
4.11	Variable speed drive settings and standardization (WD200).....	51
4.12	Checking O ₂ module (WD200).....	52
4.13	Manual start-up and program stop in pre-purge position.....	53
4.14	Ignition position.....	55
4.15	Setting ratio curve.....	56

4.16	Activating FGR.....	61
4.17	Setting FGR curve points.....	61
4.18	Measuring FGR.....	63
4.19	Capacity range.....	64
4.20	O ₂ min. value control (WD200).....	65
4.21	Setting O ₂ trim control (WD200).....	67
4.22	O ₂ trim control operating mode (WD200).....	68
4.23	O ₂ trim control load limitation (WD200).....	69
4.24	O ₂ trim control when load changes (WD200).....	70
4.25	Setting capacity controller operating mode.....	70
4.26	Setting load controller parameters.....	71
4.27	Capacity controller on/off.....	75
4.28	Boiler temperature limiting with burner control.....	76
4.29	Cold start thermal shock protection.....	76
4.30	Measuring flue gas and combustion air temperature (WD200).....	77
4.31	Activating O ₂ trim control (WD200).....	78
4.32	Backing up parameters.....	78

5 Operation

5.1	WiseDrive system.....	79
5.2	Control panel.....	82
5.3	Legend to PI diagrams.....	83
5.4	Burner operation and PI diagram, gas.....	84
5.5	Legend to time sequence diagrams.....	86
5.6	Time sequence diagram, gas use.....	89
5.7	Burner automation description, gas use.....	91
5.8	Gas valve proving.....	94

6 Maintenance

6.1	Burner maintenance.....	95
6.2	Maintenance during shutdown.....	97
6.3	Dismounting combustion head.....	98
6.4	Dismounting and changing burner motor.....	99
6.5	Assigning servomotors.....	100
6.6	Dismounting and changing servomotors.....	101
6.7	Fault and lockout history.....	103
6.8	Testing safety and control devices.....	105
6.9	Troubleshooting.....	108
6.10	Troubleshooting error codes.....	111
6.11	Burner parts (GP).....	112
6.12	Burner part list.....	113

1 Introduction

1.1 Liability disclaimer

The delivered equipment with its accessories is always a part of a larger system. This manual does not include comprehensive instructions for planning, installing and operating a complete system. Thus, the designer, installer and operator of the equipment should have sufficient qualifications and knowledge to design, install, and operate the parts of the system, as well as the system as a whole. The system, including burner control system, must be designed and constructed according to local regulations and requirements.

The following information must be read and understood by the users of the appliance. The users must be trained and fully qualified according to local legislation for the specific work. The users of the appliances must also be capable to recognize possible hazards in the system and in the environment where the appliance is used.

This manual contains information and instructions based on product standards and regulations, and on our best knowledge. Failure to follow these instructions can lead to damage to the appliance. Erroneous use of the appliance or the failure to follow any instructions or warnings in the manual or this disclaimer can lead to property damage, personal injury or death.

Oilon is unable to accept any liability for damage in case of:

- failure to follow these instructions
- other use than what is explained in this manual
- use by unqualified personnel
- the use of spare parts not provided by Oilon.

Your legal rights are governed by a Limited warranty, the terms of which are incorporated herein by reference. Any modification at the product, if not approved by Oilon, is disclaimed and may void your rights under the Limited warranty.

1.2 Safety precautions

Read these instructions carefully before installation, commissioning, operation or maintenance of the device. The given instructions must be followed. Throughout this manual, the following three symbols are used to point out very important information:



Use special caution. The DANGER symbol indicates an immediate hazard that will result in serious injury or death.



Use special caution. The WARNING symbol indicates a hazard that may result in serious injury or death.



Use caution. The CAUTION symbol indicates a hazard that may result in an injury.



Pay attention. The NOTICE symbol indicates a risk of damage to the equipment, components, or surroundings.



The 'i' (info) symbol indicates important information as well as useful tips and hints.

Keep these instructions as well as the electrical diagrams available near the device.

Oilon products are manufactured in accordance with general product standards and directives as well as based on our best knowledge of product design and different technologies. Operational safety is one of the leading principles in our product development. However, it is wise to be prepared, and think about safety. Read the following principal safety warnings and instructions:



Connectors in the control box are under voltage. Only authorized users may open the safety cover.



Installation, commissioning, or service of the appliance is to be carried out by authorized and trained personnel only, adhering to all local regulations and requirements.

The equipment shall be installed in accordance with the Provincial Installation Requirements, or, in their absence, the CGA B149.1 and B149.2 Installation Codes shall prevail.



IN CASE OF FIRE OR OTHER EMERGENCY

- Cut off power supply.
- Close the main fuel shut-off valve.
- Follow safety instructions.
- Contact the safety supervisor.



IN CASE OF A FUEL LEAK

- Do not light fire or touch electric equipment.
- Close the main fuel shut-off valve.
- Make sure there are no people in the leakage area.
- Make sure the leakage area is properly ventilated.
- Take appropriate action.
- Contact the safety supervisor.



Cut off power supply to the burner and close the manual shut-off valves always before any maintenance work. Cutting power is adequate when just inspecting the device.



Secure all safety covers, enclosures, and guards with all screws before start-up. Use appropriate tools.



Wear proper hearing protection and personal protective equipment, such as protective footwear, gloves, and safety goggles when necessary.



If burner start-up fails consecutively three times, do not restart burner before carefully investigating the reason for the failure.



Do not touch hot pipes or surfaces during operation or maintenance.



Permissible gas inlet temperature range is +5...+122 °F. Pay special attention to gas temperature when using LNG.



Fuel changeover shall always be done by an expert.



Pilot line is designed to be used at maximum 5% rating of full power.



Do not use PTFE tape in piping.

Emergency shutdown

In an emergency, cut off power supply to the burner. Close the manual shut-off valves. After safety check you can restart the burner. Check settings, and monitor that operation continues as normal.

Take care of the boiler room



Never light a fire in the boiler room.
Do not store any inflammable materials in boiler room.



Keep the boiler hatch closed while starting the burner and during burner operation.

- Maintain tidiness in boiler room, and keep boiler room door closed.
- Make sure that there is always enough water and pressure in the heating system.
- Make sure that the boiler and chimney are swept regularly.
- Check flue damper adjustment and the gate valve regularly.
- Make sure that the air inlet to the boiler room is open.
- Make sure shut-off valves in pressure gauges are shut.
- Make sure that the necessary components are regularly checked in accordance with rules and regulations by public authorities. This includes the system's pipework and its tightness, safety appliances in the boiler system, and the burner.
- Check the boiler and its components.

We recommend obtaining a maintenance contract.

WARNING

IF YOU SMELL GAS:

1. OPEN A WINDOW.
2. EXTINGUISH ANY OPEN FLAMES.
3. STAY AWAY FROM ELECTRICAL SWITCHES.
4. EVACUATE THE BUILDING.
5. IMMEDIATELY CALL THE GAS COMPANY.

WARNING

IN ACCORDANCE WITH OSHA STANDARDS, ALL EQUIPMENT, MACHINES AND PROCESSES SHALL BE LOCKED OUT PRIOR TO SERVICING.

IF THIS EQUIPMENT IS NOT INSTALLED, OPERATED AND MAINTAINED IN ACCORDANCE WITH THE MANUFACTURERS INSTRUCTIONS, THIS PRODUCT COULD EXPOSE YOU TO SUBSTANCES IN FUEL OR FROM FUEL COMBUSTION WHICH CAN CAUSE DEATH OR SERIOUS ILLNESS AND WHICH ARE KNOWN TO CAUSE CANCER, BIRTH DEFECTS OR OTHER REPRODUCTIVE HARM.

IMPROPER SERVICING OF THIS EQUIPMENT MAY CREATE A POTENTIAL HAZARD TO EQUIPMENT AND OPERATORS.

SERVICING MUST BE DONE BY A FULLY TRAINED AND QUALIFIED PERSONNEL.

WARNING

DO NOT ATTEMPT TO START, ADJUST OR MAINTAIN THIS BURNER WITHOUT PROPER TRAINING OR EXPERIENCE. FAILURE TO USE KNOWLEDGEABLE TECHNICIANS CAN RESULT IN EQUIPMENT DAMAGE, PERSONAL INJURY OR DEATH.

1.3 Product overview**Intended use**

This is an automatic forced draught burner. The burner can be used on most heating appliances; for warm and hot water boilers, steam boilers, hot air generators, and various types of process heating. They are also designed to suit furnaces with high back pressure.

As standard, the burners are mounted in horizontal orientation. The standard setup is designed to operate in the altitude of max. 1,640 ft above sea level and the electrical equipment in the altitude of max. 3280 ft above sea level.

See **Other technical data and requirements** for the information on standard applicable fuels. Burners using other fuels are available upon request.

Construction

The surface of the housing is finished with durable high-gloss paint. Electrical installations and burner service are easy to perform because the top cover is removable. The stainless steel alloy combustion head and the diffuser disc can withstand high temperatures.

The motor output components of the fan motor (short-circuit protection, thermal protection, contactor) must be designed according to the site.

In burners supplied with a control system, all burner operation systems are handled automatically. In the event of a burner failure, the system will stop the burner automatically. Only qualified personnel may operate the burner manually.

Each burner is tested separately before delivery to the customer.



This product is in accordance with



Our gas burners comply with standard UL295, oil burners with UL296, and dual-fuel burners with both of the above-mentioned standards.

The manufacturing time is found in the type plate. The product's expected lifespan is at least 15 years, if it and its components are used and maintained properly.

For more information on products, visit our website at www.oilon.com.

Type labelling

GKP-700	M-II	WD200	LN80	C2
1	2	3 4	5	6 7

Label element 1: Series, fuel	
KP	Light fuel oil
RP	Heavy fuel oil
GP	Gas
GKP	Light fuel oil
GRP	Gas, heavy fuel oil

Label element 2: Burner frame size categorization	
50... 1200	Higher value = higher capacity

Label element 3: Method of control	
H	Two-stage
M	Modulating
MH	Modulating gas, two-stage oil
ME	Modulating with a separate fan

Label element 4: Burner capacity size categorization	
-, I, II, III	Higher value = higher capacity

Label element 5: Control system (additional code):	
WD100	Electronic fuel/air ratio control system
WD200	Electronic fuel/air ratio control system with O ₂ control and variable speed drive (VSD)

Label element 6: Combustion head type referring to typical NO _x -emissions (additional code)	
LN30	LN30 = 30mg/kWh
LN60	LN60 = 60mg/kWh
LN80	LN80 = 80mg/kWh

Label element 7: Combustion head length (additional code)	
-, C1, C2, C3	Combustion head length C only in use in LN80 burners.

Type plate

The following illustration shows an example of the type plate of Oilon burners:

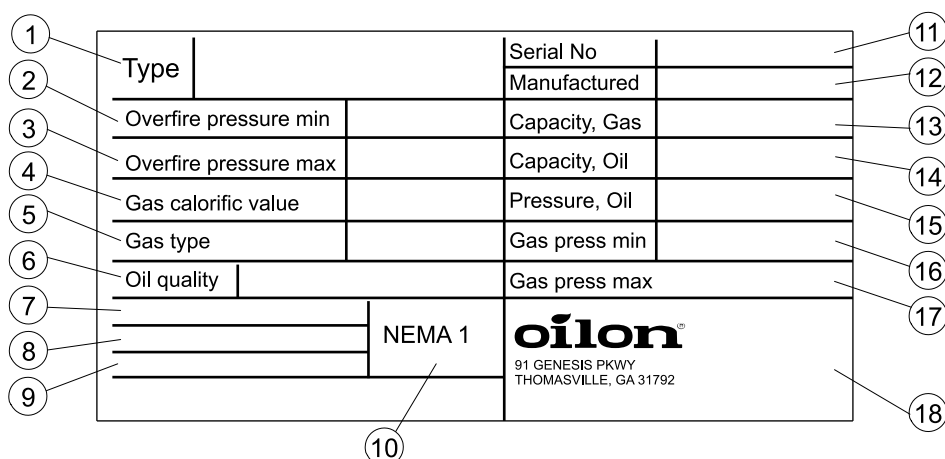

Type plate US ver. 2

Pos.	Description	Pos.	Description
1	Burner type: KP = Light fuel oil RP = Heavy fuel oil GP = Gas GKP = Light fuel oil and gas GRP = Heavy fuel oil and gas	9	Oil pump supply voltage, input power and current, V / Phase / Hz / hp / A
		10	Degree of protection
		11	Serial number
		12	Month and year of manufacture
2	Overfire pressure min, IN.WC	13	Capacity, gas, MBTU/hr
3	Overfire pressure max, IN.WC	14	Capacity, light fuel oil, GPH
4	Gas calorific value, BTU/scf	15	Oil pressure, PSI
5	Gas type	16	Gas pressure min, IN.WC
6	Oil quality / viscosity	17	Gas pressure max, IN.WC
7	Control voltage, V / Phase / hp / A	18	Manufacturer address
8	Fan supply voltage, input power and current, V / Phase / Hz / hp / A		

1.4 Flue gas recirculation (optional)

The flue gas recirculation (FGR) reduces the NO_x content of flue gases. A certain proportion of flue gas is led back to the combustion chamber, which causes the flame temperature to drop. This influences the NO_x content of flue gas.

In general, the amount of recirculated flue gas must be adjusted to the smallest possible quantity needed to obtain the required NO_x rate. The flue gas quantity is adjusted with the throttle valve located on the FGR pipe.

If the quantity of recirculated flue gas is excessive the flame may become unstable and the CO rate may increase. The amount of flue gas to circulate is set on the control panel. To optimize the result, burner is adjusted to operate according to preset FGR-curves.

For detailed information and instructions, see the chapters *Installation* and *Commissioning*.

1.5 Handling and storing





Storing and recycling

Store the device and its equipment in the manufacturer's packaging in a dry and airy place. Protect device from dust and humidity. Condensation, formation of ice and ingress of water are not permitted. If these requirements are not met, the device's safety functions may be compromised. The storage time is one year after which the product and its components must be checked before commissioning.

Documentation is a part of the product, and it must be passed on together with the device, also with a second hand product. Pass on the documents delivered with device to the owner at installation, and advise them to keep them properly. Make sure that operating instructions are available near the device.

	<p>Recycle product packaging. The metal and plastic parts of the device are made of recyclable materials. Also all electrical components are recyclable, and should be handled according to local regulations.</p>
---	--

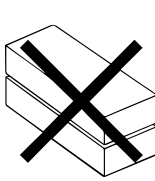
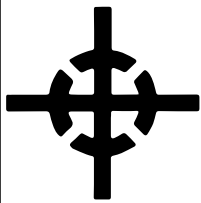
Follow international packing markings

Symbol	Description	Symbol	Description
	<p>Fragile, handle with care</p>		<p>Arrows to indicate which side is facing up (THIS WAY UP)</p>
	<p>Protected from water (KEEP DRY)</p>		<p>Non stackable</p>
	<p>Center of gravity</p>		<p>Chain images to indicate lifting points (SLING HERE)</p>

2 Technical data

2.1 Burner technical data



This manual may include additional information about other burner types. However, the manual is valid only for the burner, mentioned on the front page and in the burner data table.



Following information applies to standard deliveries.

Burner data

Burner	GP-350 M	GP-450 M
Capacity, MMBtu/h	2.6–16.1	3.2–20.8
Burner motor 3~ 208–600 V, 60 Hz		
• Output, hp	10	15
• Current, A/460 V	11.9	17
• Speed, rpm	3,510	3,510
Weight, lbs*	705	992

*Burner only. The weight varies depending on the content of the delivery.

Turndown ratio, gas 1:6 (100...16.6%)

Working diagrams



Using the burner outside the range shown in the working diagrams is not allowed.

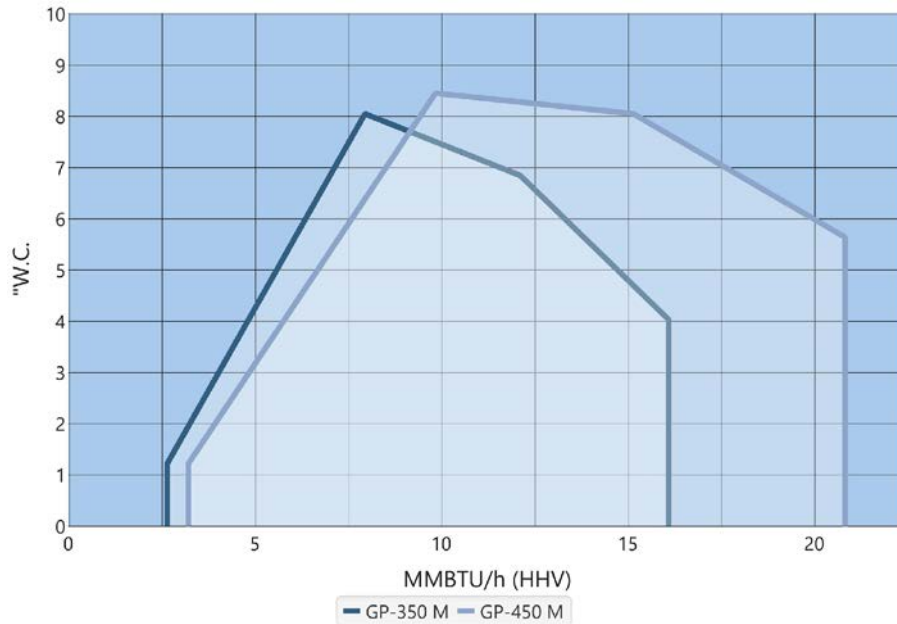

GP-350 M - 450 M (UL) ver. 2



Tested in laboratory conditions (ambient temperature 68 °F).

2.2 Other technical data and requirements

Fuel, gas use	Natural gas When using other gases than natural gas, the composition of the gas must be known. Consult burner manufacturer on the suitability of the burner for special gases.
Gas inlet pressure to burner max.	Natural gas: 8 - 200 "W.C. LPG: 11 - 200 "W.C.
Max. demand for combustion air, gas use	13.5 cfh/MBtu
Efficiency, natural gas	35,31 ft ³ /h ≈ 13.5 MBtu efficiency, when heat value is 961.91 Btu/ft ³
Performance, natural gas	950 - 1050 btu/sc.ft

Control voltage	115 V (-15%...+10%) 50 Hz / 60 Hz 1-phase
Motor voltage options	220 V 60 Hz 3-phase 400 V 60 Hz 3-phase 460 V 60 Hz 3-phase 575 V 60 Hz 3-phase

Sound pressure level L _{pfA}	77.0 ± 0.5 dB
---------------------------------------	---------------



For reducing noise level, contact the manufacturer or consult the Oilon Selection Tool (available for download on the Oilon website).

Degree of protection	NEMA 3
Ambient temperature range	32...+ 122 °F

2.3 Burner control technical data

Burner control	LMV5...
Mains voltage	120 VAC -15/+10 %
Locking during undervoltage conditions	< 96 VAC
Transformer / primary side	120 VAC
Transformer / side 1	12 VAC
Transformer / side 2	2 x 12 VAC
Mains frequency	50–60 Hz 6 %
Power consumption	< 30 W
Permissible input current / differential air pressure switch	0.5 A / 230 VAC -15/+10 %
Permissible input current / status input	1.5 mA/120 VAC -15/+10 %
Perm. current rating of control terminals <ul style="list-style-type: none"> ● fan motor contactor ● burner failure ● ignition transformer ● gas valves ● oil valves 	<ul style="list-style-type: none"> ● 1 A/120 VAC -15/+10 % ● 1 A/120 VAC -15/+10 % ● 1.6 A/120 VAC -15/+10 % ● 1.6 A/120 VAC -15/+10 % ● 1.6 A/120 VAC -15/+10 %
Permissible operation ambient temperature	-4...+140 °F

Block diagram of contact links

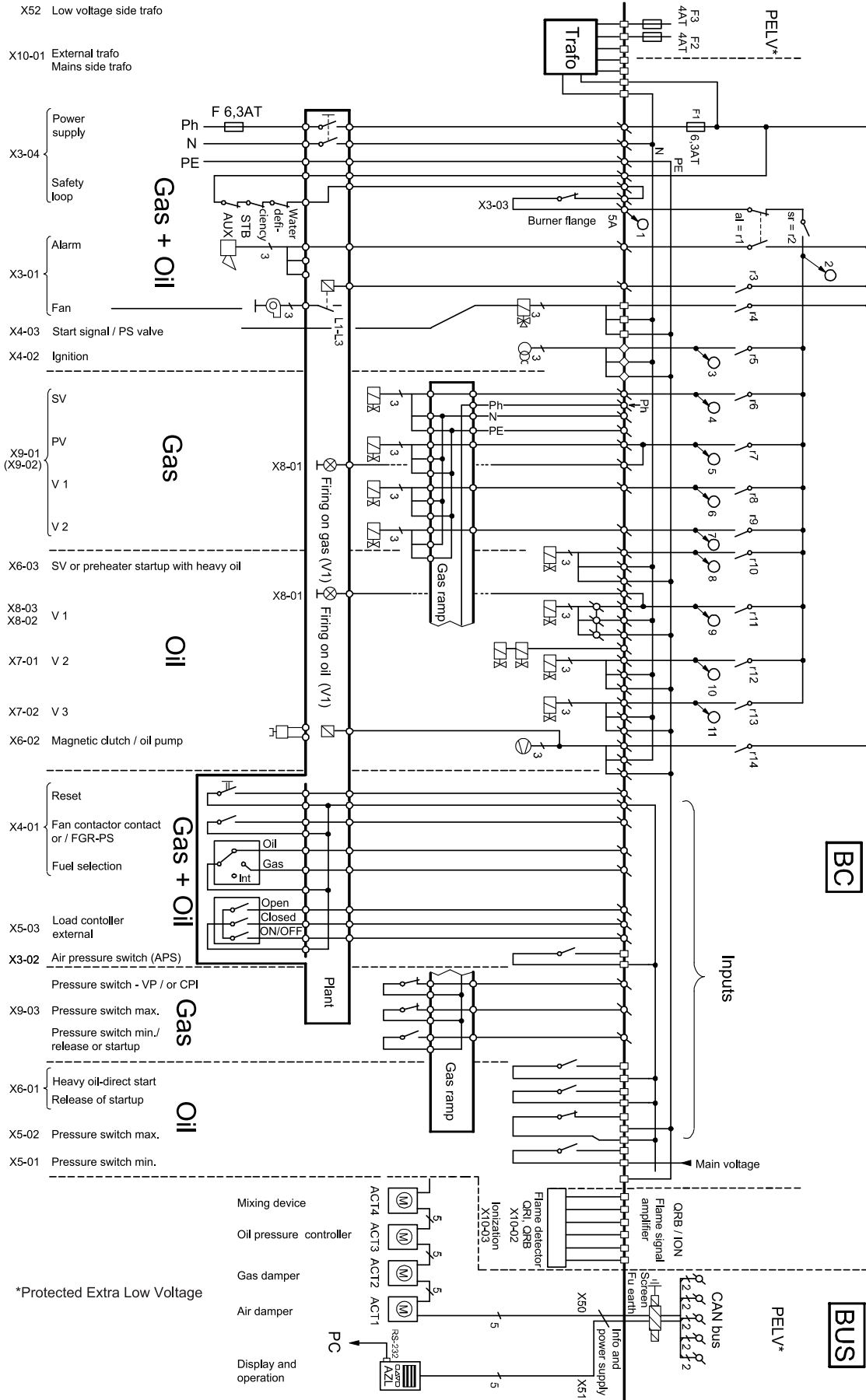

Block diagram ver. 7

Inputs / outputs (VSD)

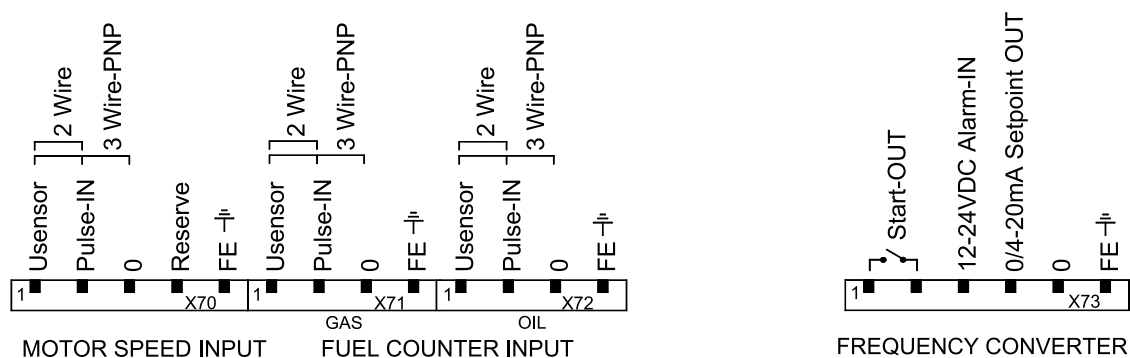

Connection diagram ver. 3

2.4 Servomotor technical data

Servomotor	SQM45...	SQM48.497	SQM48.697	SQM91.391A9
Mains voltage	2 x 12 VAC	2 x 12 VAC	2 x 12 VAC	2 x 12 VAC
Power consumption	9 – 15 VA	26 – 34 VA	26 – 34 VA	40 VA
Angular adjustment	90°	90°	90°	90°
Accuracy	±0.2°	±0.2°	±0.2°	±0.8°
Torques, operation / holding	26.55 / 13.27 lbf·in	177 / 177 lbf·in	310 / 310 lbf·in	531 / 531 lbf·in
Running time	10 s - 120 s	30 s - 120 s	60 s - 120 s	30s
Degree of protection	NEMA 3	NEMA 3	NEMA 3	NEMA 4
Permissible ambient temperature	-4...+140 °F	-4...+140 °F	-4...+140 °F	-4...+140 °F

2.5 Display and operating unit technical data

Display and operating unit	AZL...
Supply voltage	24 VDC -15/+10 %
Power consumption	< 5 W
Protection degree	NEMA 3
Permissible operation ambient temperature	-4...+140 °F

NOTICE

Protect the equipment from condensation, ice, and water ingress.

2.6 O₂ module technical data (WD200)

O ₂ module	PLL52...
Mains voltage, sensor heating	110 VAC -15/+10 %
Mains voltage	2 x 12 VAC
Power consumption	4 VA

O ₂ module	PLL52...
Analog inlet, oxygen sensor	QGO21.000D27
Analog inlet, combustion temperature	Pt1000 / LG-Ni 1000
Analog inlet, flue gas temperature	Pt1000 / LG-Ni 1000
Analog inlet, bus interface	CAN
Protection degree	NEMA 3
Permissible ambient temperature	-4...+140 °F

NOTICE

Protect the equipment from condensation, ice, and water ingress.

2.7 Oxygen sensor technical data (WD200)

Oxygen sensor	QGO20...
Measuring cell	ceramic zirconium dioxide cell
Mains voltage, measuring cell heating	110 VAC -15/+10 %
Power consumption	max. 90 W, typically 45 W (controlled)
Measuring cell temperature	1292 °F ±122 °F
Measuring range	0.2...20.9 % O ₂
Flue gas velocity	3.28...32.81 ft/s
Protection degree	NEMA 2
Max. temperature, flange	+482 °F
Max. temperature, connecting head	+158 °F
Max. temperature, flue gas	+572 °F

NOTICE

Protect the equipment from condensation, ice, and water ingress.

2.8 Flame detector technical data



Flame detector values and connections depend on burner control system.

QRI	
Operation type	continuous
Supply voltage, operation	14 VDC ±5%
Supply voltage, testing	21 VDC ±5%
Signal voltage	0–5 VDC
Power consumption	< 0.5 W
Connected detector cable max. length	5.9 ft

QRI	
Auxiliary detector cable max. length	328 ft
Protection degree	NEMA 3
Permissible operation ambient temperature	-4...+140 °F

- integrated signal amplifier
- continuous or interrupted use
- mains frequency filtering
- does not detect electric arc used for ignition
- spectral sensitivity range $\sim 1\text{--}3\ \mu\text{m}$
- QRI2A2.B180B front-viewing
- QRI2B2.B180B side-viewing

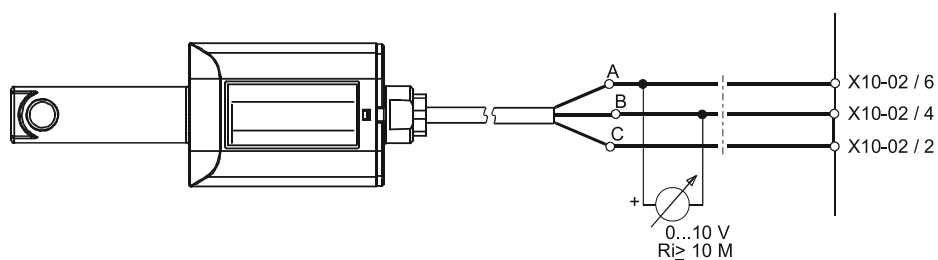

QRI connection ver. 1

A	Black	X10-02 / 6	Signal line
B	Blue	X10-02 / 4	Reference line
C	Brown	X10-02 / 2	Power line

3 Installation

3.1 Space requirements

Leave enough space on each side of the burner for installation, commissioning, and maintenance purposes. The minimum space requirements are presented in the following.



Installation, commissioning, or service of the appliance is to be carried out by authorized and trained personnel only, adhering to all local regulations and requirements.

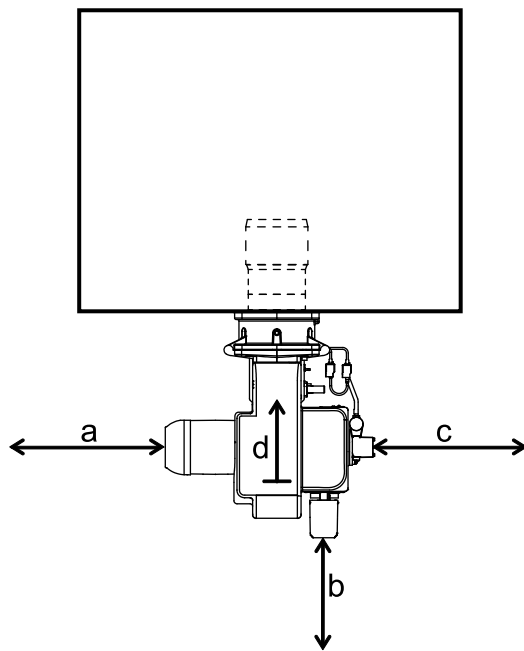

Legend	Minimum dimension, ft
a (left)	2.6
b (front)	3.6
c (right)	2.6
d (top)	3.3

Space requirements ver. 1

It is recommended to leave more space around the burner. These are only the minimum requirements.

3.2 Removing protective covers and lifting the burner



- The unit may be lifted only by qualified personnel with a good understanding of the regulations and safety instructions for lifting.
- Always use all indicated lifting points of the particular lifting direction.
- Do not go under the burner or any other suspended load.



If you set the burner on a pallet, always remove the oil filter.

The burners are attached and supported to a transportation base. The base can be lifted from all sides with a forklift. When lifting the package, the center of gravity must be in the middle between the forks to avoid falling.

Use hexagonal key to remove and attach protective covers.

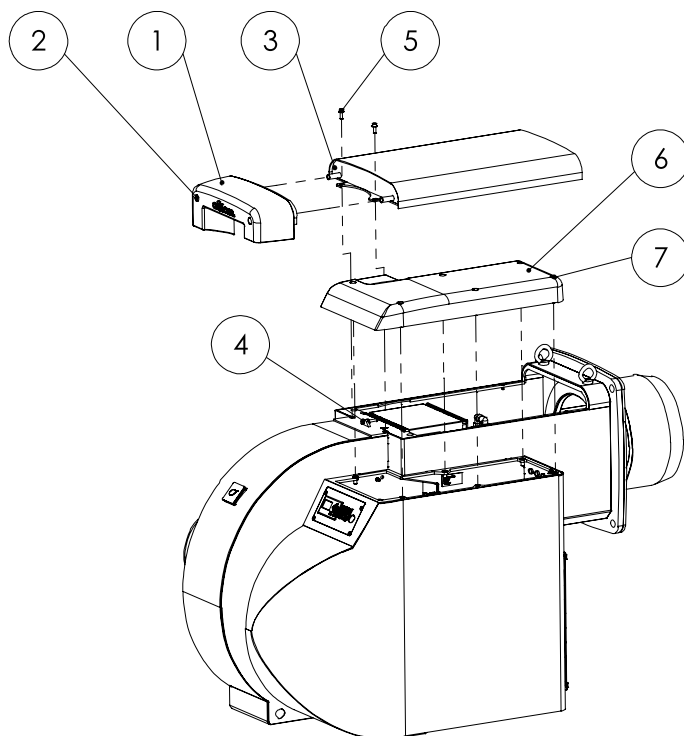

D042848 ver. 2

Pos.	Item
1	End cover
2	End cover, fastening screws, 2 pcs
3	Frame cover (15 kg / 33 lbs)
4	Frame cover, tightening screw, 1 pcs
5	Frame cover, fastening screws, 2 pcs
6	Electric casing protective cover
7	Electric casing protective cover, fastening screws, 6 pcs

To remove protective covers

1. Loosen the screws of the end cover and remove the cover.
2. Loosen the tightening screw of the frame cover, and also remove its fastening screws. Draw the cover about 20 mm (0.79 inch) towards yourself and remove it.
3. Loosen the screws of electric casing protective cover, and remove the cover.
4. Reassemble covers in reverse order.

To lift the burner

Remove end cover before placing the lifting straps. Use lifting straps or chains with hooks to lift the burner as shown in the illustration. Protect the burner from possible friction during lifting.

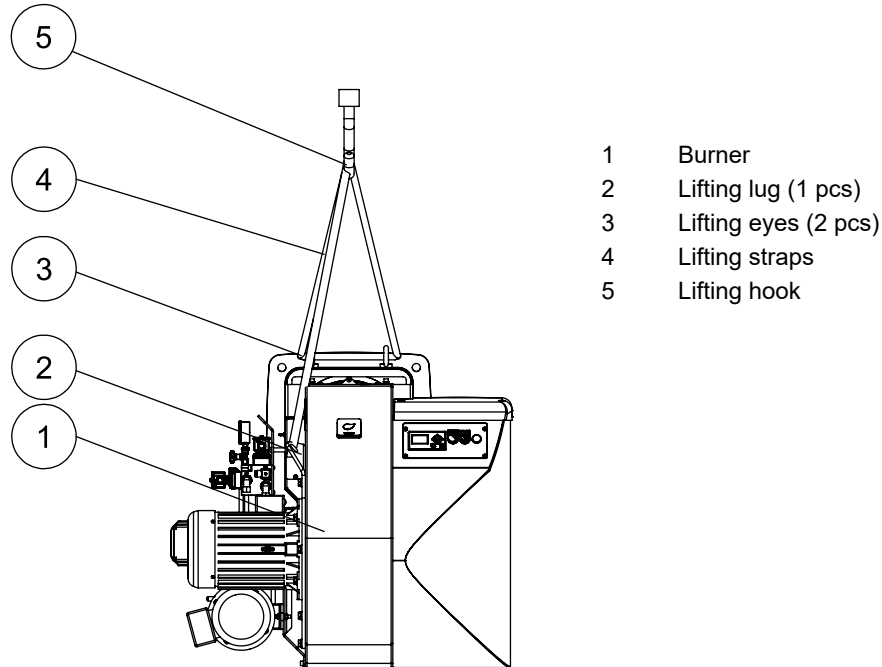

D046885 ver. 1

3.3 Installing burner

- Coat bolt threads with graphite-bearing grease before fitting.
- Fasten burner to boiler in accordance with the given dimensions.
- Install burner so that motor axle is on horizontal level. Do not install burner upside down.
- Install burner so that it can be turned fully open and combustion head can be detached.
- Remove transportation support after fastening.
- Protect the burner from weather conditions during installation and when installed.

NOTICE

Install the burner firmly. Vibration may cause damage to the burner or its components.

Burner dimensions (GP)

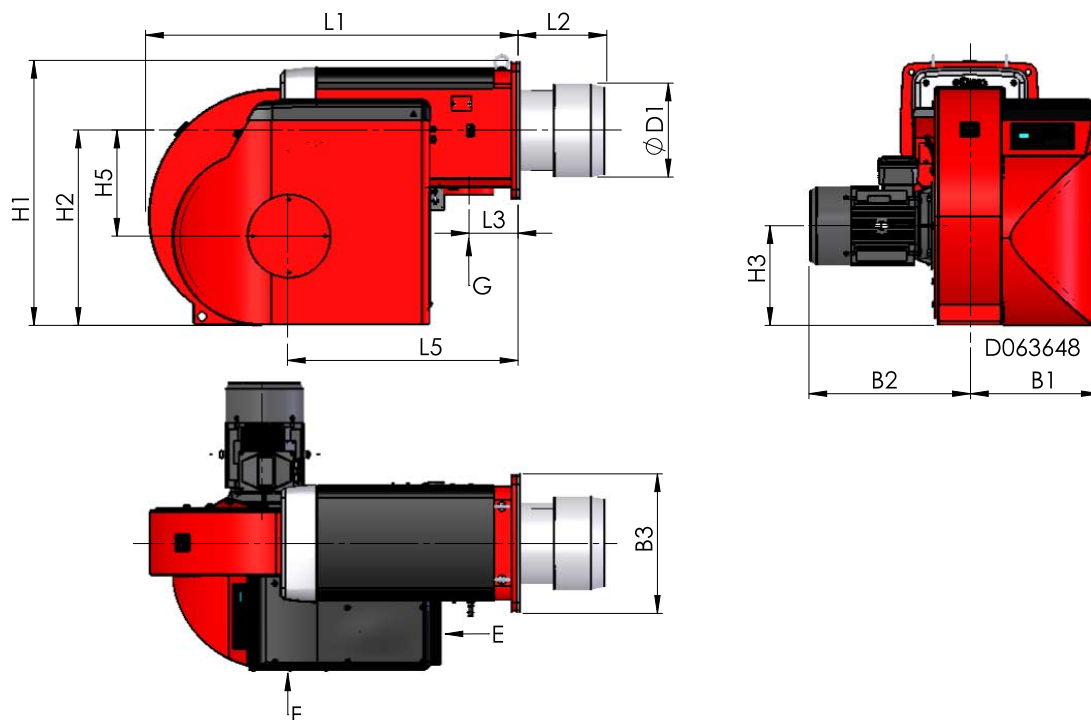

D063648 - GP-320 M - 450 M WDX00 / WD3x ver. 1

Dimensions in inches

Burner	L1	L2	L3	L5	H1	H2	H3	H5	B1	B2	B3	ØD1
GP-350 M	53.54	13.78	7.68	31.89	37.01	27.36	13.98	13.58	19.29	22.83	19.29	12.60
GP-450 M	57.87	13.78	7.68	35.83	41.34	30.31	15.55	16.54	20.08	25.59	21.65	14.57

Connections	
G	Gas inlet
E	Electrical connection
F	FGR - Flue Gas Recirculation

3.4 Combustion head and masonry dimensions

Combustion head mounting dimensions

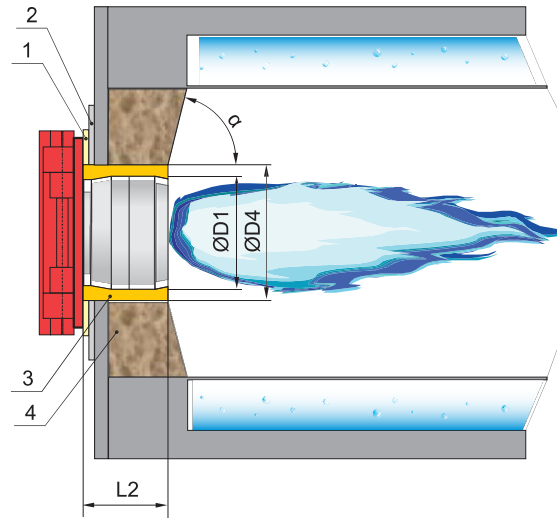
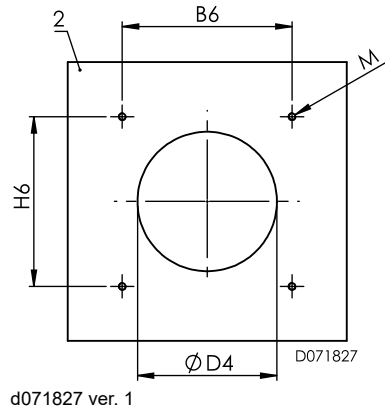

Masonry 1 ver. 3

Pos.	Item	Pos.	Item
1	Gasket, thickness 0.3 inch	3	Ceramic wool or equivalent
2	Mounting panel	4	Masonry

Burner	B6	H6	ØD4	M	ØD1	L2	α
350 M	15.75	15.75	14.96	4xM20	12.60	13.78	60–90°
450 M	18.31	18.31	17.32	4xM20	14.57	13.78	60–90°

Dimensions in inches.

Installing extension plate (optional)

The extension plate is delivered loose.



Follow lifting instructions when lifting the burner.



The extension plate is heavy. Be careful not to injure your fingers while lifting the plate off a surface.

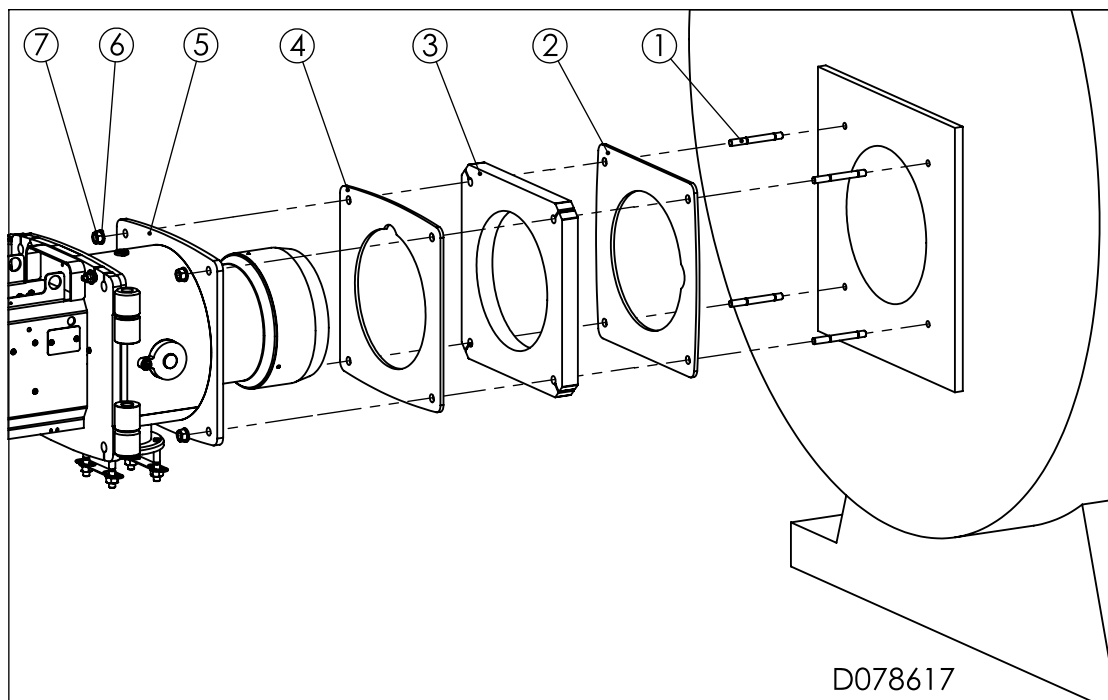

d078617 ver. 2

Pos.	Item	Pos.	Item
1	Stud screw, 4 pcs	5	Burner flange with combustion head
2	Flange gasket (boiler side)	6	Washer, 4 pcs
3	Extension plate	7	Hex nut, 4 pcs
4	Flange gasket (burner side)		

To install the extension plate:

1. Attach the supplied stud screws securely to the boiler.
2. Thread a lifting strap or lifting chain through the large opening in the extension plate.
3. Slide the first gasket into place over the stud screws.
4. Using the strap or chain, lift the extension plate. Slide the plate onto the stud screws.
5. Let the extension plate rest on the stud screws, and remove the strap or chain. Push the plate against the boiler.
6. Slide the second gasket into place over the stud screws.
7. Lift the burner into place. Tighten the burner against the extension plate using the stud screws, washers and nuts.



If the boiler comes with threaded rods already welded into place, use the rods instead. Follow the procedure above.

3.5 Gas valve selection table

Gas valves

Burner	Min. inlet gas pressure PSI"	Max. inlet gas pressure PSI"	Gas valve	
			Type	Size inch
350 - 450 M	2.18	7.25	VGD	2" - 4"



If the gas inlet pressure is less than 8 in.WC or if some other gas except natural gas is used, case-specific evaluation must be made.

3.6 Installing burner to gas supply line

Supply line

If necessary, decrease the supply gas pressure with pressure regulating assembly. The gas supply line after the pressure regulator must be of the same size or one size larger than the valve train size.

As standard, the gas connection to the burner is from the right side. The valves shown in the following example may vary from those delivered.

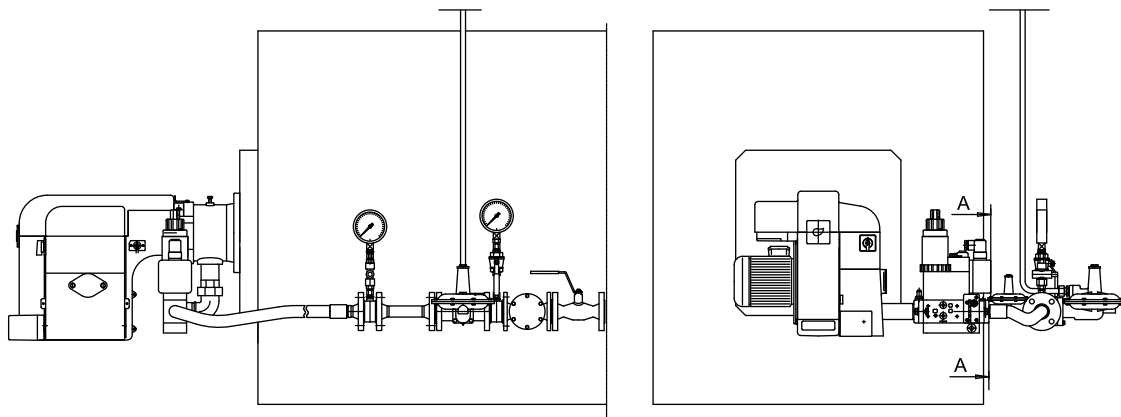

B352U ver. 3



If the gas inlet pressure is not stable, stabilize with pressure regulator.

NOTICE

Install gas lines in accordance with regulations by local public authorities.

NOTICE

Check that there is a separate filter upstream from gas equipment.

NOTICE

Install the gas valve so that the valve is not subjected to mechanical stress.

NOTICE

Vent gas piping before first start-up.

NOTICE

Clean and check piping prior to the installation of gas pressure regulating assembly.

Installing gas valve and gas pipe support



Install support if gas valve size is 2.5" or larger.

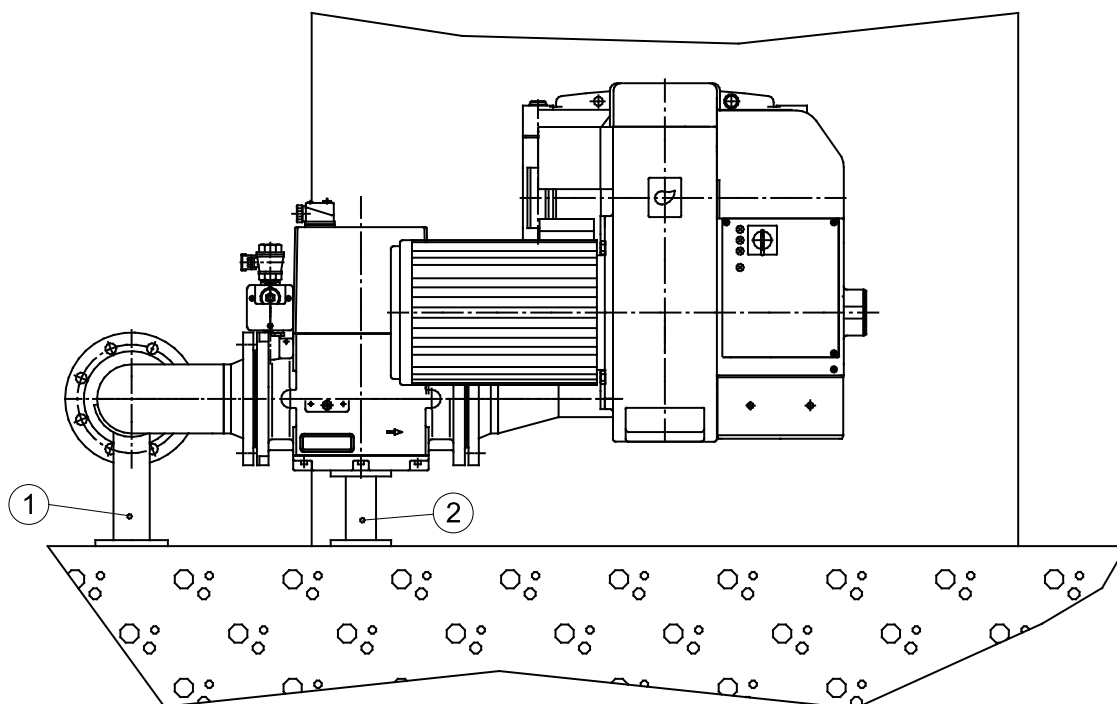

B-349T ver. 1

Place the supports under the gas pipe (1) and gas valves (2) as depicted in the illustration.

3.7 Installing gas pressure regulating assembly

NOTICE Adhere to the values given by the equipment manufacturer.

Installing pressure regulator

Consider the following factors when selecting pressure regulator:

- gas supply pressure
- secondary pressure
- the volume of gas to be fired
- type of gas

If the gas inlet pressure is higher than the Pmax. value given in burner's technical data or PI diagram, reduce the gas inlet pressure in the regulating assembly. If the pressure regulator is not equipped with a safety relief valve and safety shut-off valve, install these valves according to the instructions given by the manufacturer. Also any impulse tubes must be installed according to the instructions given by the regulator manufacturer.

i If the gas inlet pressure is not stable, stabilize the pressure with the pressure regulator.

Example of gas pressure regulating assembly

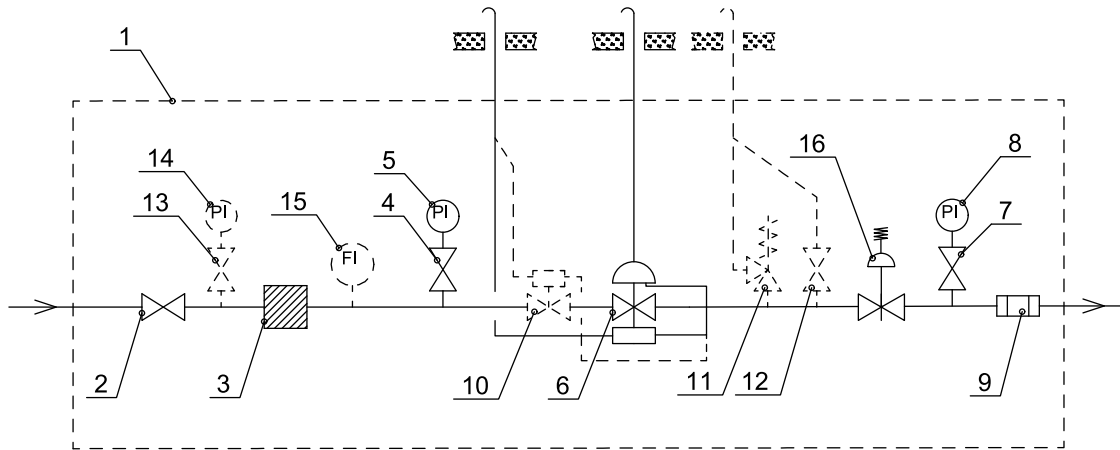

B311Z ver. 4

Pos.	Item	Pos.	Item
1	Gas pressure regulating assembly	9	Bellows compensator/gas hose
2	Ball valve	10	Safety shut-off valve, if not incl. in press. regulator
3	Gas filter	11	Safety relief valve, if not incl. in press. regulator
4	Pressure gauge valve	12	Blow-off, when necessary
5	Pressure gauge, high pressure	13	Pressure gauge valve, when necessary

Pos.	Item	Pos.	Item
6	Pressure regulator with safety shut-off valve and safety relief valve	14	Pressure gauge, high pressure, when necessary
7	Pressure gauge valve	15	Fuel flow meter, can also be on low pressure side, when necessary
8	Pressure gauge, low pressure	16	Pressure regulator

3.8 Changing the fuel type from natural gas to LPG



This information applies only when liquefied petroleum gas (LPG) is used.

Model 350

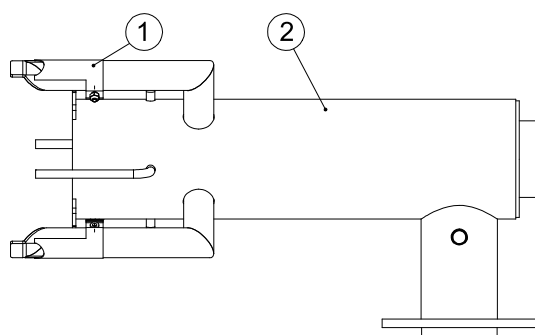

- 1 Adjusting band
- 2 Gas nozzle

Gas nozzle adjusting band (LPG) ver. 2

Model 450

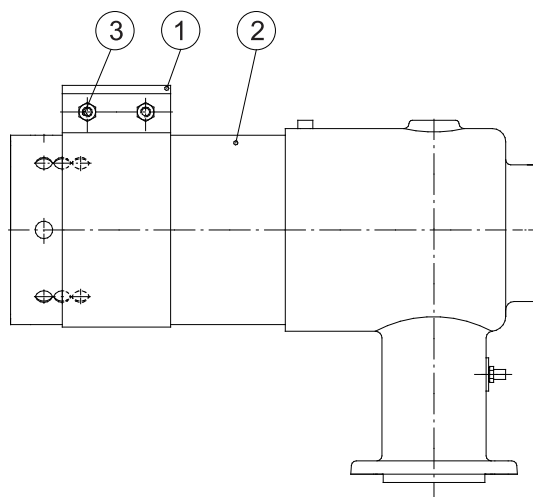

- 1 Adjusting band
- 2 Gas nozzle
- 3 Fixing screw of adjusting band

Gas nozzle adjusting band (LPG) ver. 3

To use the burner with liquefied petroleum gas (LPG), install an adjusting band in the gas nozzle, allowing you to adjust the square area of the nozzle apertures.

- Adjust the final position of the band according to the capacity demand.
- Note the quantity of gas flow in relation to function of the compound regulator.
- Check the combustion values with flue gas analysis and, if necessary, adjust the burner by changing the air damper and the gas pressure.
- After the conversion, supplement the burner's type plate with a label or other marking indicating the type of gas fired in the burner.

3.9 Installing FGR duct system

FGR duct system

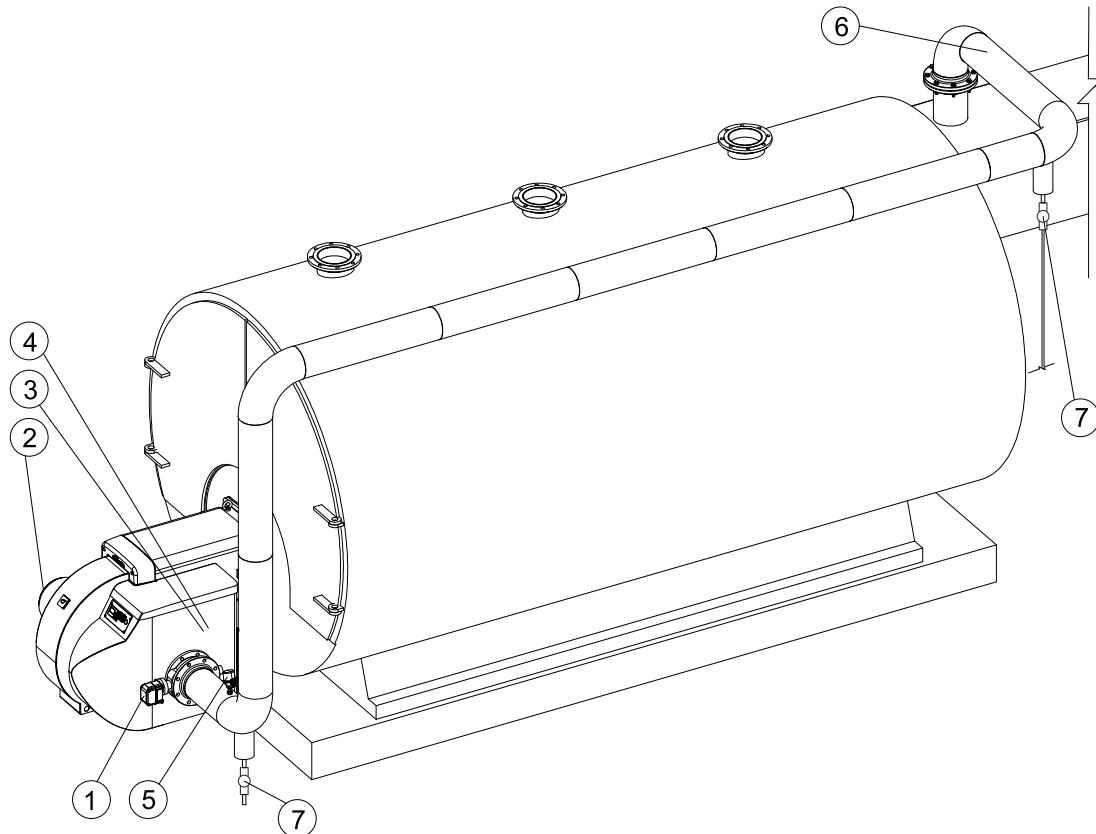

FGR Installation_monoblock ver. 3

Pos.	Item	Pos.	Item
1	Control damper	5	Temperature sensor
2	Combustion air fan	6	FGR duct
3	Combustion air throttle valve	7	Condensate drain valve
4	Combustion air		

In monoblock burner constructions, pos. 2 and 3 are integrated parts of the burner.

Burner	Minimum diameter of FGR pipe
350 M - 450 M	6"

Designing FGR piping

When designing the piping, consider the special circumstances of FGR operation.

The temperature in the piping varies constantly during the operation causing expansion and contraction of the pipes. The temperature differences also cause condensation in the pipe line.

In long pipe runs the pipe line length can change by over 1" per 212° F. Thus extra load builds up on pipe connection point, which may result in component failures.

Apply the following rules of thumb for the construction:

- Use carbon or stainless steel for FGR piping. Pipe wall must not be too thick.
- Route the duct with a minimum number of elbows, still allowing a normal expansion and contraction of the duct. Place pipe supports to avoid excessive load to pipe connection.
- Leave space for the pipe joint movement during the expansion and contraction of the duct.
- Provide condensation drains, if needed. Check the drain volume needs.

To mount FGR duct system:

1. Place the inlet to the stack as close as possible to the boiler or economizer. Set cutting in 45° angle.
2. Set control damper close to the burner.
3. Finish the FGR duct pipe joint carefully with seal welding, flange or screw connection. Make sure that the joint is tight and no air can enter the duct.
4. Place condensate drains both at the beginning and the end of pipe line.
5. Install one drain upstream from the FGR control valve, and another in the FGR shut-off valve, if used.
6. In case of heavy condensation, add a condensate drain to the bottom of the housing.
7. Anchor supports to provide stability in the duct.

NOTICE

Excessive load on the pipeline may cause damage to the burner or its components. The construction must be self-supporting.

Installing temperature sensor

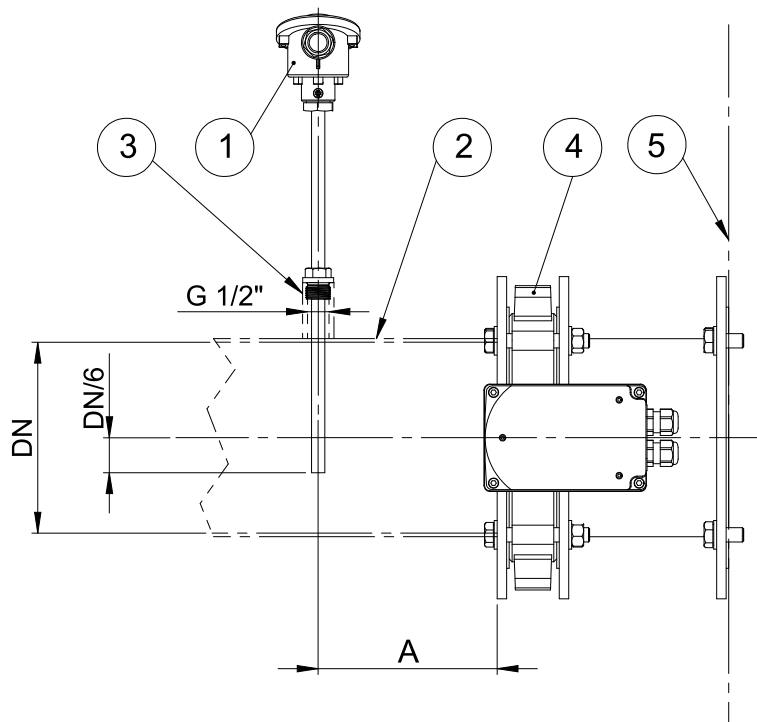

D055288 ver. 1

1	Temperature sensor	4	Butterfly valve
2	FGR pipe (*)	5	Burner
3	Sleeve (*)	A	Min. 7.87 in
* not included in delivery			

3.10 Electrical connections



Electrical installation may be carried out by authorized and trained personnel only.

Connect the burner according to the electrical diagrams delivered with burner. Follow general and local standards and regulations as well as requirements set for electrical connections for electrical equipment.

Configure the burner installation with a switch that allows it to be disconnected from the supply mains. Grounding must be in order before commissioning burner.

See the electrical diagram for maximum cable lengths.

Burners with an integrated control system have separate power supply connections for both the burner's motor and its control circuit. The supply for the control circuit needs to be connected directly to the burner wiring base. Motor outputs require two cable connections: the burner's control circuit needs to be wired to the motor output's

control circuit and the motor output to the motor. The exact connections depend on the installation's configuration and must be made on site in accordance with local rules and regulations.

Also note that in certain models, the motor output is integrated in the burner wiring base.

In burners with an external control cabinet, the supply for the control circuit needs to be connected to the cabinet. In the cabinet, the burner control circuit needs to be wired to the motor output. Burner configurations may vary; please refer to the electrical diagrams supplied with the burner.

Keep the cables and wires of different voltage circuits separate.

- When using a variable speed drive, do cabling work and grounding according to manufacturer instructions.
- Position the variable speed drive as near to the motor as possible to avoid interference caused by long cabling.
- If possible, use a separate cable rack for supply cables. Otherwise, keep the supply cables separate from control and bus cables.
- Check that shielded cables are properly connected.

4 Commissioning

4.1 First start-up



Secure all safety covers, enclosures, and guards with all screws before start-up. Use appropriate tools.



If burner start-up fails consecutively three times, do not restart burner before carefully investigating the reason for the failure.



After the first start-up check the cleanliness of the gas filter weekly and replace if necessary. If the filter remains clean, inspection period can be extended to one month.



While adjusting the burner, make sure that minimum and maximum values for burner capacity are not exceeded. The values are marked on the type label.



Factory settings may change during commissioning.



Vent fuel lines before first start-up.

First start-up check list

Check the following before first start-up:

- instructions from boiler and burner manufacturers are followed
- piping is done properly, and joints on pipes and components have been tested for leaks
- piping is purged with steam or compressed air after installation. Dismount filters, nozzles and components which may be damaged during purging
- check that all screws are in their places and carefully tightened after installation
- boiler and its components are in proper working order and ready for use
- there is adequate air inlet to the boiler room for the burner to have sufficiently air for combustion
- connections are correct and motor rotation direction is correct
- valves in supply line(s) are open and fuel is available at a suitable pressure
- manual control valves are in correct positions
- fuel filter is installed

- gas inlet pressure is correct
- equipment is installed correctly and is in working condition
- chimney is properly connected, unobstructed and flue gas damper is open

To start the burner:

1. Open the manual fuel shut-off valves.
2. Switch on power supply.
3. Switch on the burner from the burner control switch.

To stop the burner:

Turn the burner control switch to OFF position.

Commissioning data

- Gas type
- Wobbe index (calorific value)
- Volumetric gas flow rate
- Minimum and maximum heat output rates
- Supply gas pressure
- Adjusted gas pressure
- CO and CO₂-percentage content of the flue gases
- O₂- percentage content of the flue gases
- Combustion air temperature
- Flue gas temperature
- Gas nozzle pressure
- Fan pressure
- Air and fuel servomotor positions

4.2 Adjusting combustion head (GP)

Combustion head components GP-350 M

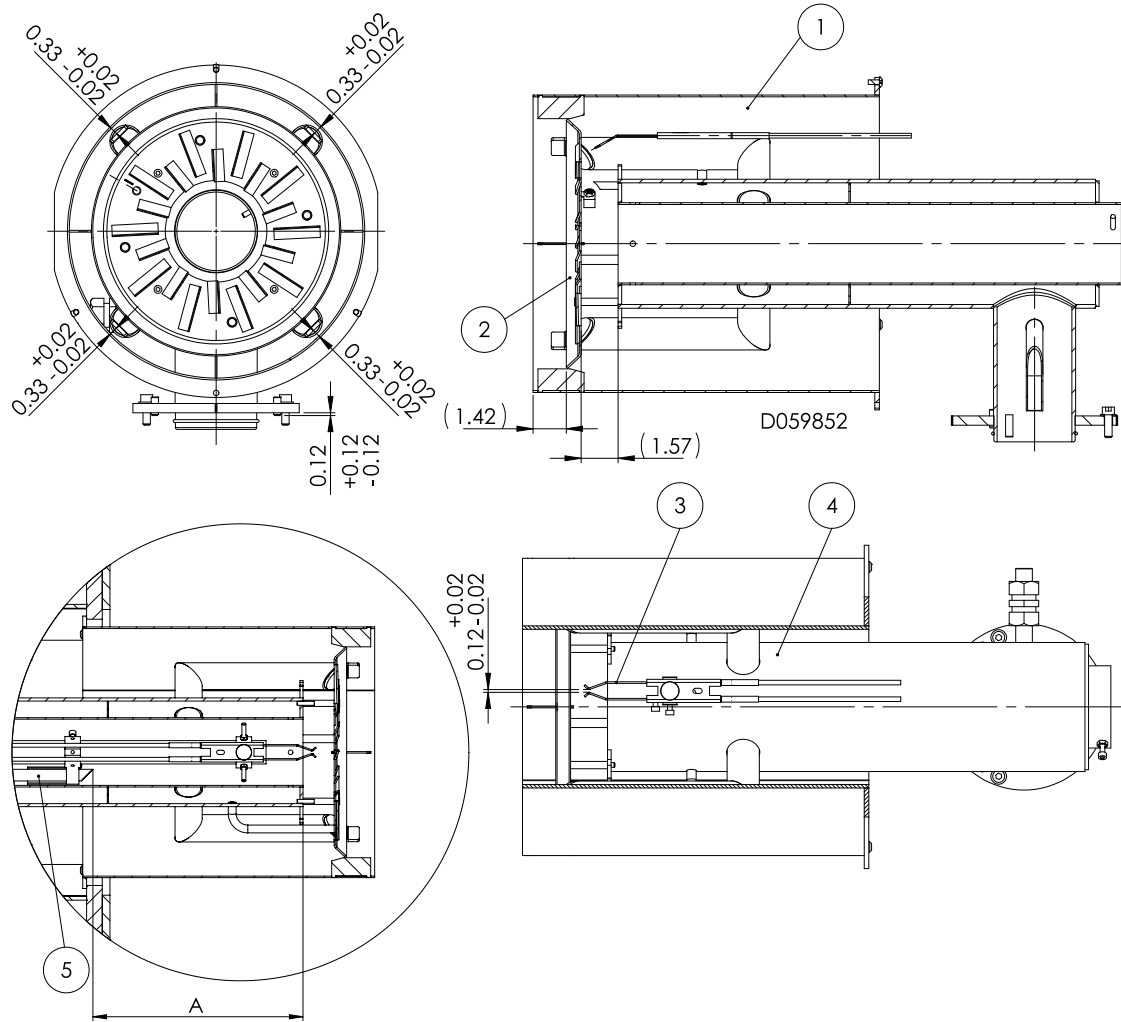

Pos.	Item	Pos.	Item
1	Combustion head	4	Gas nozzle
2	Diffuser disc		Ignition gas nozzle
3	Ignition electrode	A	10.63 in

Separate pilot gas line, GP-350 M

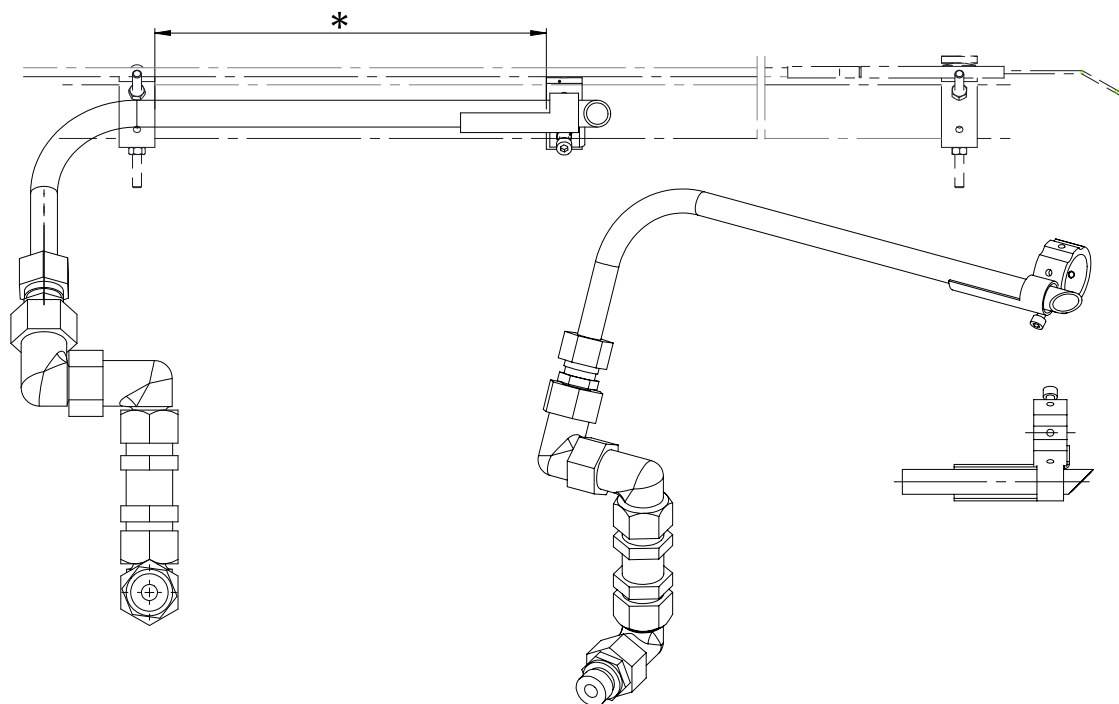

d081136 ver. 1

*The retaining ring for the pilot gas line is attached to the ignition electrode support pipe between the centering standoffs.

Combustion head components GP-450 M

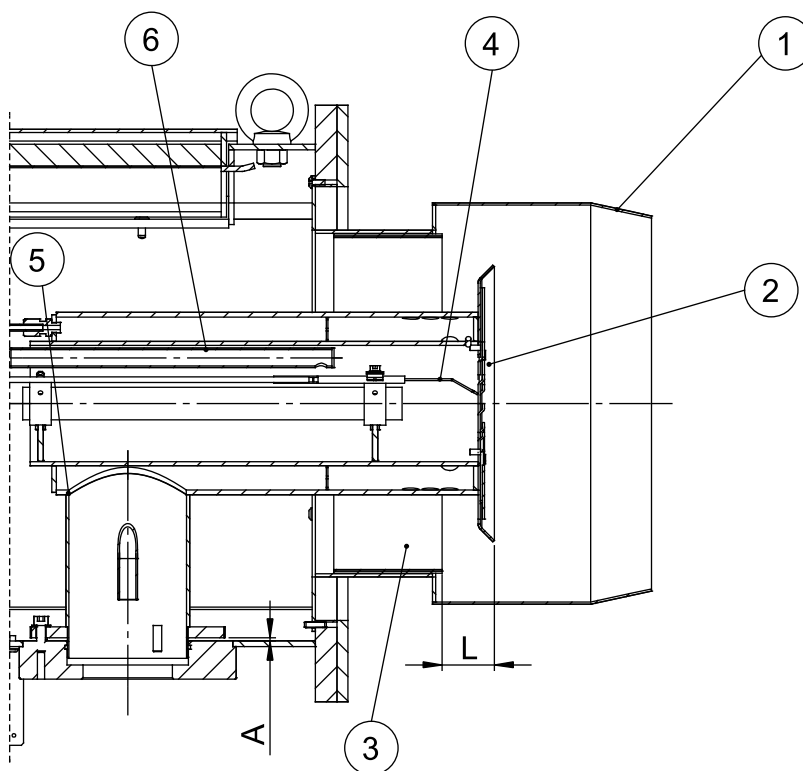

D043818 ver. 2

Pos.	Description
1	Combustion head
2	Diffuser disc
3	Adjustment ring
4	Ignition electrode
5	Gas nozzle
6	Ignition gas nozzle
A	0.12 in \pm 0.12 in
L	Factory setting : 1.77 in

Setting ignition electrodes GP-450 M

Set the following as shown in the illustration:

- ignition electrode horizontal distance from the nozzle (L)
- ignition electrode vertical distance from the nozzle (H)
- distance between electrodes (K)

Maximum tightening torque of ignition electrodes is 1 Nm.

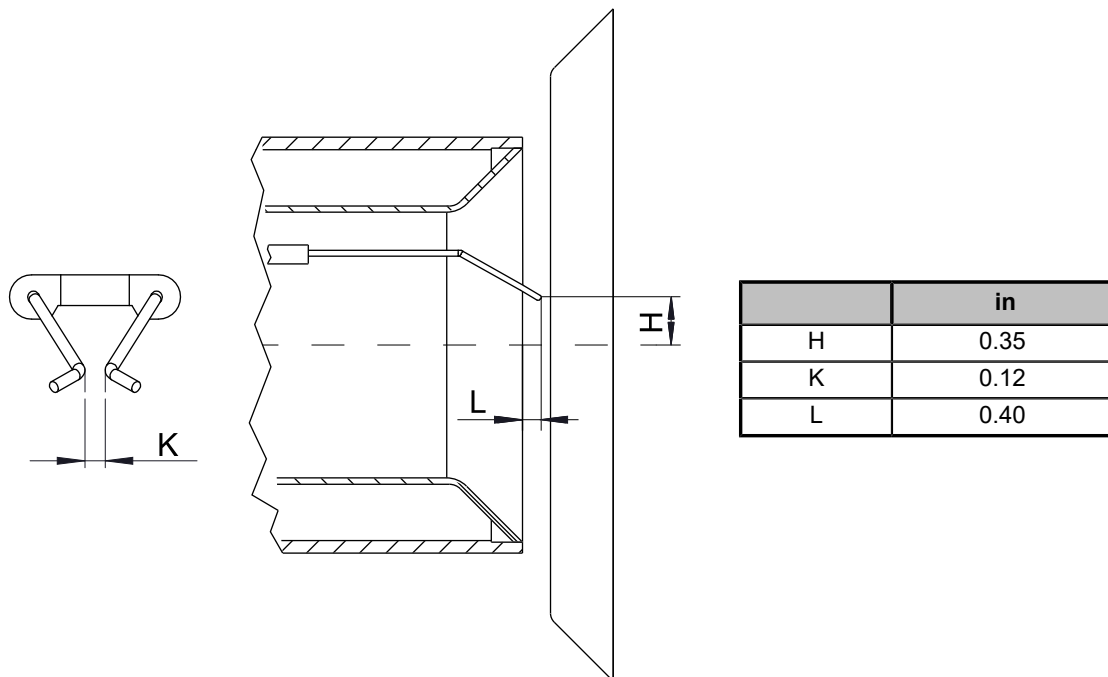

A496V ver. 5

4.3 Adjusting combustion air (GP-450 M)

Adjustment ring positioning

Adjustment ring position has an effect on the pressure in the combustion head. Adjust the pressure by moving the adjustment ring back and forth. This changes the gap between the adjustment ring and the diffuser disc.

- At low capacity, the adjustment ring is at the front.
- At high capacity, the adjustment ring is at the back.

If...	Then...	Result
The adjustment ring is too far forwards at full capacity	There is too much pressure drop in the combustion head.	<ul style="list-style-type: none"> Poor ignition, OR Poor combustion due to inadequate amount of air (high CO content), OR Flame tear-off from diffuser disc when switching to higher capacity
The adjustment ring is too far towards the back at low capacity.	There is not enough pressure drop in the combustion head.	Poor combustion (O ₂ values too high)

Minimum pressure drop in the combustion head

Fuel	"W.C
Gas use	0.8

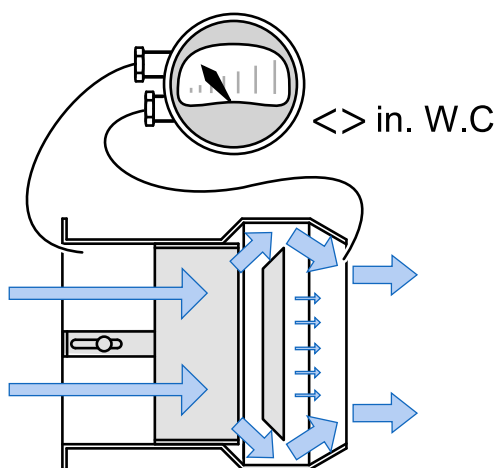

Combustion air US ver. 1

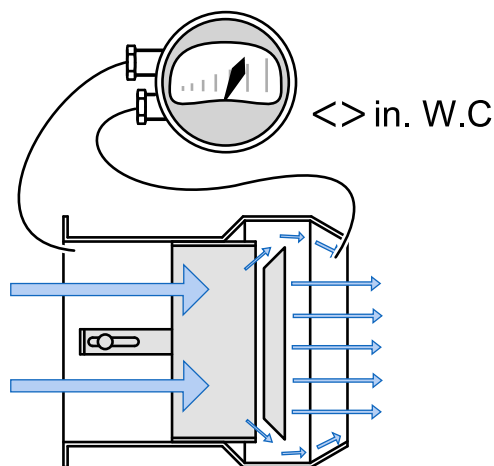

Guideline values

Capacity	Fuel	O ₂ level %
Ignition, minimum and part capacity	Gas	3.5–4.5
Full capacity	Gas	2–4



If you alter the position of the adjustment ring in relation to the diffuser disc, the quantity and velocity of combustion air in the combustion head will change. Check combustion values with flue gas analysis and, if necessary, adjust combustion air quantity to an adequate level.

4.4 Adjusting combustion differential air pressure switch

Combustion differential air pressure switch

The combustion differential air pressure switch monitors the pressure difference generated by the burner fan.

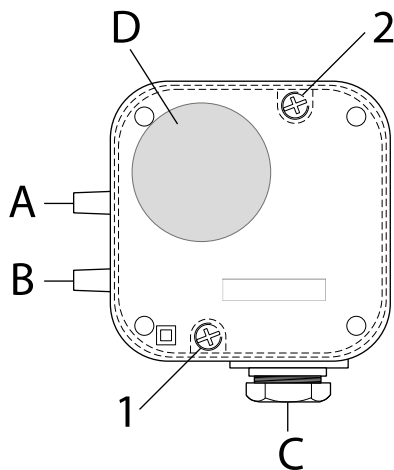

Pos.	Item
A	Higher pressure
B	Lower pressure
C	Electrical connections
D	Adjustment wheel
1 and 2	Cross-head screw

LGW A2 ver. 2

If the pressure difference does not rise above the switch setting value, the burner will shut down. The differential air pressure switch should be set to trigger before the CO concentration in the flue gas exceeds 1 vol-% (10,000 ppm).

Burner	Factory setting "W.C.
350 M	16.5
450 M	18.1

When using variable speed drive

- factory setting is set to 4.01 "W.C.
- maximum adjustment range should be between 35 Hz and 50 Hz



To ensure proper burner function, the differential air pressure switch may have to be readjusted to match the actual conditions at the installation site. Make sure not to exceed the given CO limit.

To adjust differential air pressure switch setting at current nominal burner capacity

1. Remove the screws and open the protective cover.
2. Start the burner.
3. Turn the switch slowly towards the maximum until the burner shuts down.
4. Turn the switch approx. 2.0 "W.C. from this point backwards (towards the minimum).
5. Attach the protective cover and reset.

4.5 Adjusting gas pressure switch

Gas pressure switch, max.

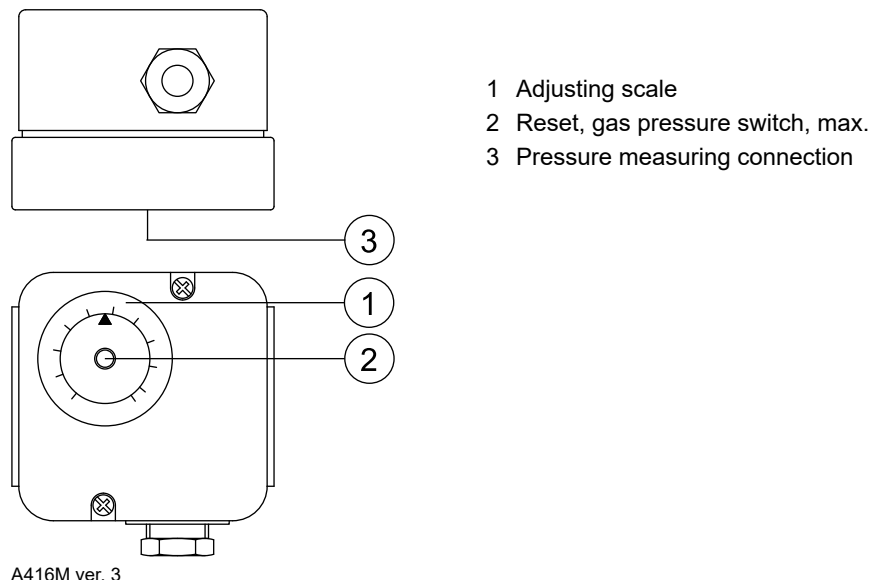

Gas pressure switch max. should cause a permanent interlocking if burner capacity increases to be more than 1.15 times the nominal value, or if the pressure exceeds more than 1.3 times the nominal pressure.

Burner	Factory setting "W.C.
350 M	22.1
450 M	20.9

To adjust gas pressure switch to maximum, without flue gas analyzer

Adjust gas pressure switch after burner adjustments and flue gas analysis.

1. Turn gas pressure switch adjusting scale to the maximum position.
2. Run burner to the desired maximum capacity.
3. Increase burner capacity to be 1.15 times the desired maximum capacity by raising gas pressure.
4. Slowly turn switch to the minimum until burner shuts down. Now the adjustment is correct.
5. Reset gas pressure switch.
6. Run burner back to the desired maximum capacity by decreasing gas pressure.

To adjust gas pressure switch to maximum, with flue gas analyzer

Adjust gas pressure switch after burner adjustments and flue gas analysis.

1. Turn the gas pressure switch to its maximum value.
2. Adjust burner to the desired maximum capacity; for example so that O₂ content = 2.5–3.0 % and CO content < 50 ppm.
3. Increase the capacity by raising the gas pressure until the O₂ content = 1.0 % and CO content < 2000 ppm.

4. Slowly turn the gas pressure switch towards its minimum setting until the burner shuts down. The pressure switch is now correctly configured.
5. Reset the error.
6. Decrease gas pressure to normal value. Check combustion values.

To adjust gas pressure switch, min.

Burner	Factory setting "W.C.
350 M - 450 M	8.0

Scale precision $\pm 15\%$

1. Open switch transparent cover.
2. Set burner to full capacity.
3. Set the switch to trigger on a 20–40 % lower pressure than the gas inlet pressure to burner.
4. Close cover.

Gas pressure switch min. should cause a permanent interlocking.

If gas pressure switch triggers a temporary burner shutdown during burner start-up or during operation, it has to be set on lower pressure.

Gas pressure switch, gas valve proving

Gas valve leaking is tested by using a pressure switch. Switch adjustment according to previous instructions.

4.6 Setting gas pressure regulator SKP

The operating area of the gas pressure regulator is determined by the spring installed inside the pressure regulator. Spring operating area is described in the table below.

Springs can be ordered from Oilon Webshop.

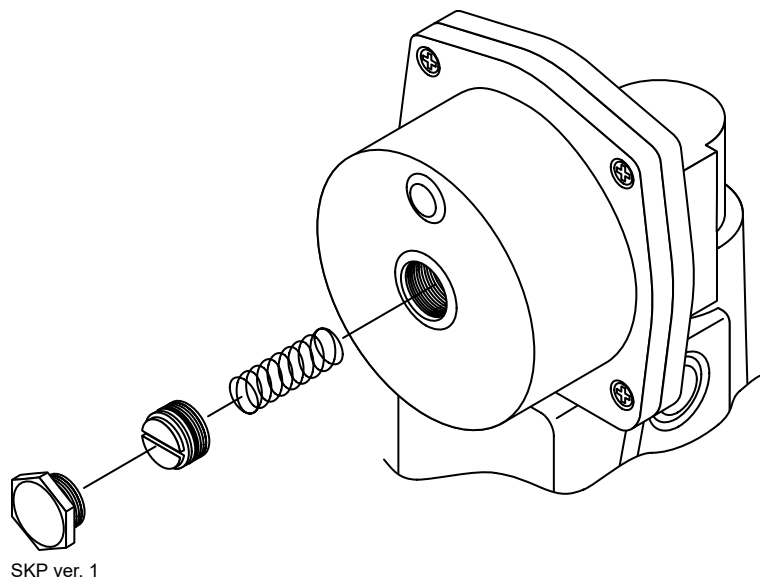

SKP ver. 1

To change spring:

1. Remove the plug.
2. Remove the slot-head screw by turning counter-clockwise with a chisel-point screwdriver.
3. Replace the spring.

Assemble in reverse order.

NOTICE

Do not overtighten the component's screws. The component may become damaged.

Spring type	pG ("W.C.)	Δp / 360	Color	Model
AGA29	≤ 8.8	2.2	blank	SKP25.0
AGA22	6.0 ... 48.2	11.9	yellow	SKP25.0
AGA23	40.2 ... 100.4	24.5	red	SKP25.0
AGA22	40.2 ... 281.0	-	yellow	SKP25.4
AGA23	≤ 602.8	245	red	SKP25.4

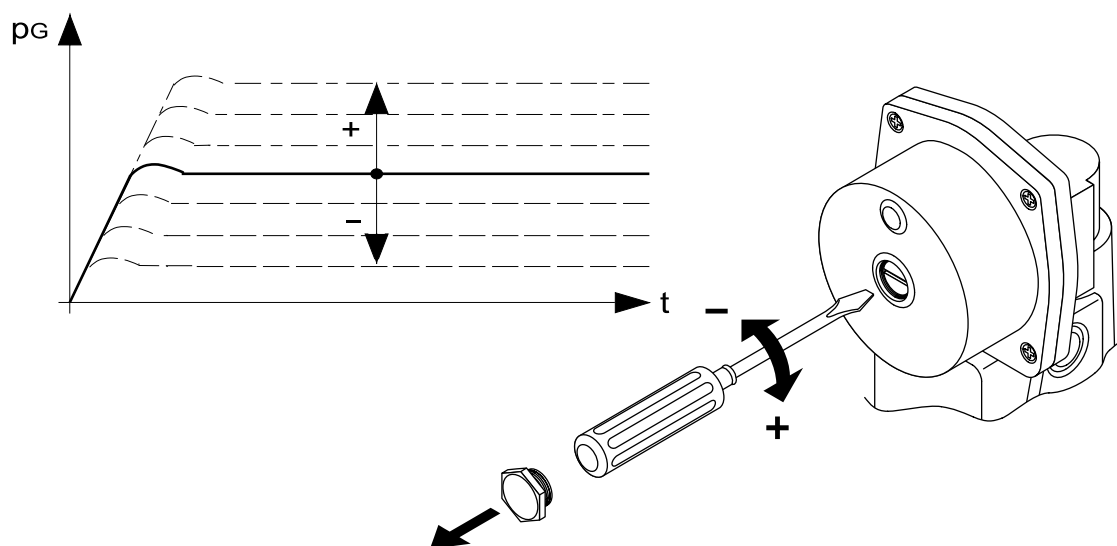

SKP2 ver. 1

To adjust gas pressure:

1. Remove the plug.
2. Adjust the outgoing pressure by turning the slot-head screw counter-clockwise with a chisel-point screwdriver.
 - When turning counter-clockwise, the pressure drops.
 - When turning clockwise, the pressure rises.

Measure the gas pressure with a pressure gauge when the burner is on.

4.7 Setting gas pressure regulator FRS

The operating area of the gas pressure regulator is determined by the spring installed inside the pressure regulator. The factory setting of standard spring p_2 is 4 - 12 in.WC.

Springs can be ordered from Oilon Webshop.

Setting pressure regulator at minimum load

1. Start burner at minimum load. At minimum load throttle valve setting is 5°-10°.
2. Adjust combustion to safe level using flue gas analysis. Measure pressure regulator outlet pressure from gas valve measuring point.
3. Turn adjustment spindle clockwise until gas amount corresponds with required burner minimum load. Check combustion using flue gas analysis, when raising pressure. Adjust burner if necessary.



Check gas valve measuring point position from the gas valve manufacturer manual.



Adjust the pressure regulator outlet pressure to its final level with the burner running at full load.

To adjust outlet pressure

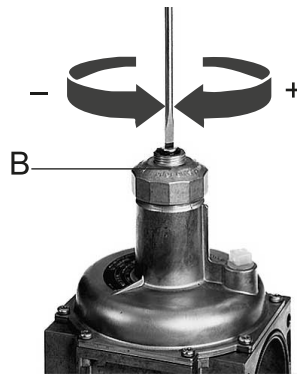
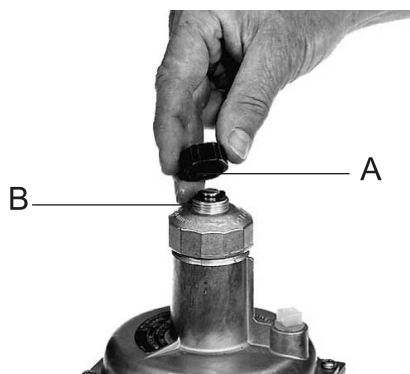

219598a ver. 1

1. Unscrew protective cap **A**.
2. Use a chisel-point screwdriver. to adjust spindle **B**:
 - a. Turn the spindle B clockwise. This increases the outlet pressure.
 - b. Turn the spindle B counterclockwise. This reduces the outlet pressure.
3. Check the setpoint.
4. Screw on the protective cap **A**.

To replace setting spring

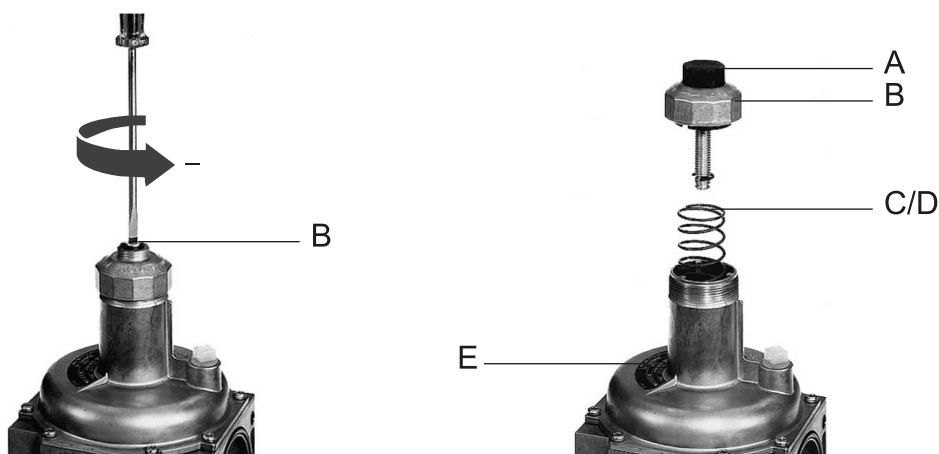

219598b ver. 1

1. Remove protective cap **A**. Release spring by turning adjustment spindle **B** counterclockwise. Turn spindle to stop.
2. Unscrew complete adjustment spindle **B** and remove spring **C**.
3. Insert new spring **D**.
4. Assemble complete adjustment spindle and adjust desired offset.
5. Screw on protective cap **A**. Stick adhesive label **E** onto typeplate.

NOTICE

Do not overtighten the component's screws. The component may become damaged.

Sealing final settings

1. Check pressure regulator outlet pressure. If necessary, adjust it to be sufficient for full load setting.
2. Finally seal setting by threading wire through sealing holes in protecting cap and pressure regulator body.

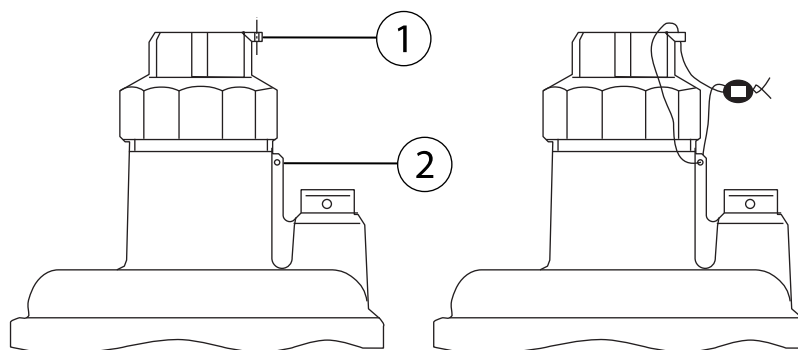

FRS4 ver. 2

- 1 Protecting cap sealing hole, \varnothing 0.06 in
- 2 Body sealing hole, \varnothing 0.06 in

	Setpoint spring range ("W.C)	Color	Nominal width Rp/DN					
			Rp 1 1/2, DN40	Rp 2, DN 50	Rp 2 1/2, DN65, 80	DN 100	DN 125	DN 150
Spring 1	1.0–3.6	brown	229 851	229 874	229 883	229 892	229 901	229 909
Spring 2	2.0–5.2	white	229 852	229 875	229 884	229 893	229 902	229 910
Spring 3	2.0–8.0	orange	229 853	229 876	229 885	229 894	229 903	229 911
Spring 4	4.0–12.1	blue	229 854	229 877	229 886	229 895	229 904	229 912
Spring 5	10.0–22.1	red	229 869	229 878	229 887	229 896	229 905	229 913
Spring 6	12.1–28.1	yellow	229 870	229 879	229 888	229 897	229 906	229 914
Spring 7	24.1–44.2	black	229 871	229 880	229 889	229 898	229 907	229 915
Spring 8	40.2–60.3	pink	229 872	229 881	229 890	229 899	229 908	229 916
Spring 9	56.3–80.4	grey	229 873	229 882	229 891	229 900	243 416	243 417

4.8 Measuring gas pressure

General rules for gas pressure measurement

1. Shut off the burner.
2. Loosen the test point screw.
3. Attach a silicone hose to the test point connection. Attach a gauge to the other end of the hose.
4. Start the burner.
5. While the burner is running record gas pressure readings using the instructions below.
6. Perform adjustments if needed.
7. Shut off the burner.
8. Finally close all the test point connections and remove measurement equipment.



Make all adjustments when the burner is running!



All stated pressure values are only for reference. The actual values may vary depending on operating conditions.

Measuring nozzle pressure

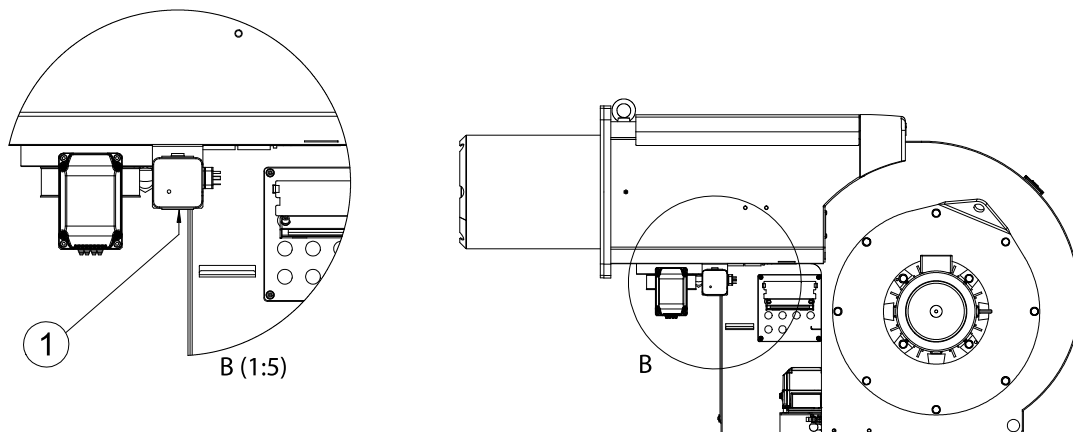

D050332 ver. 2

1. Nozzle pressure at nominal capacity

Burner	Test point 1 ("W.C.)
350 M	17.7
450 M	11.2

Check the tables below for adjusted pressure values.

Measuring inlet and adjusted pressure

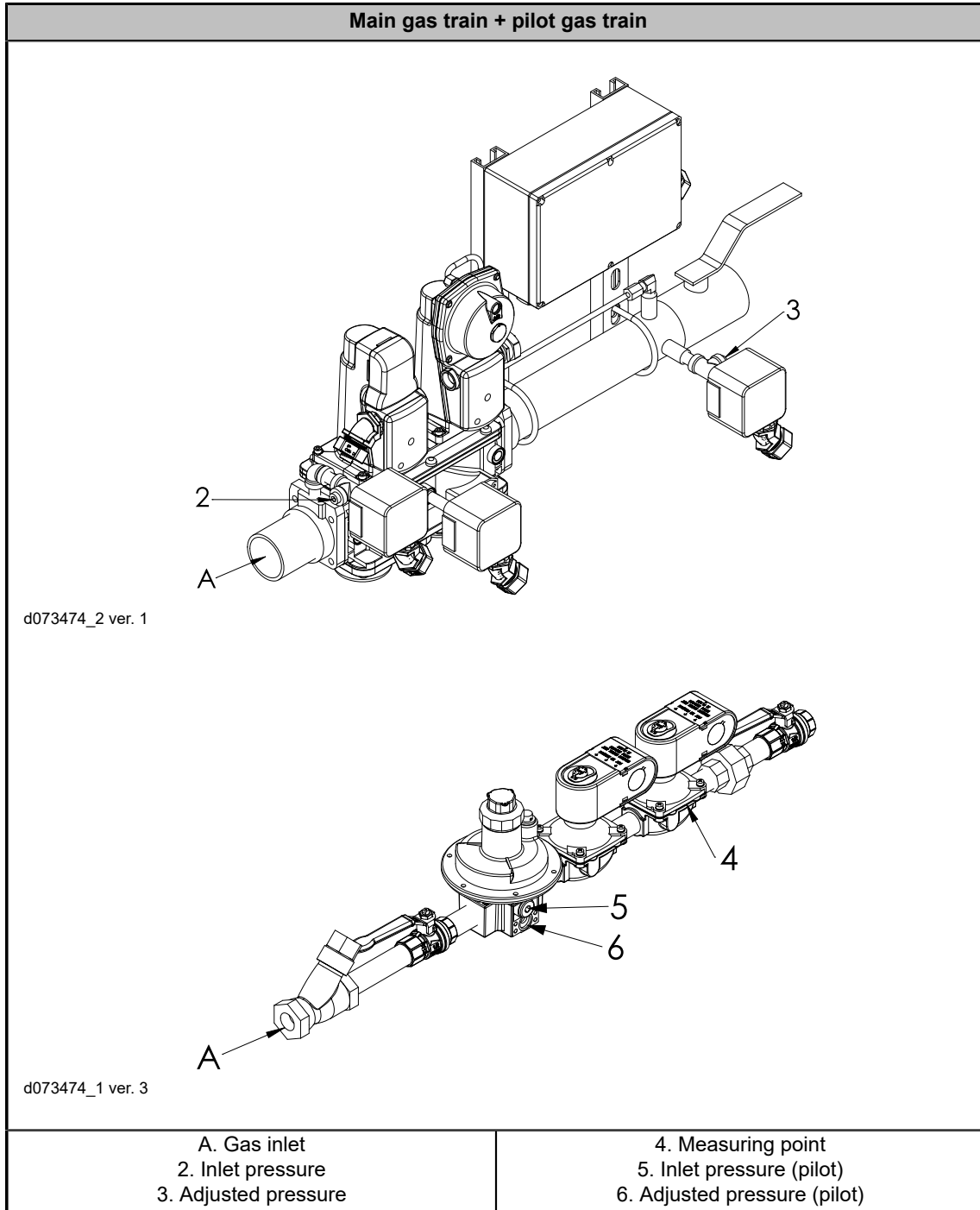

Burner	Test point 2 ("W.C.)	Test point 3 ("W.C.)
350 M	max. 280 (VGD)	32.1
450 M	max. 280 (VGD)	41

4.9 Operating and display unit menu

Menu structure

Menus are divided into two user levels.

First user level is User, and it does not require password.

Second user level is Service. It is a password protected level for commissioning and maintenance personnel.

Operation

User can scroll through and change clock and counter settings for standard burner operation.

			Description
Operation			
	BoilerSetpoint		
		SetpointW1	Internal setting W1, °F Internal setting W1, PSI
		SetpointW2	Internal setting W2, °F Internal setting W2, PSI
	UserMaxLoad		
		MaxLoadMod	Max. load modulating
		MaxLoadStage	Max. load stage
	Fuel		Displaying and selecting the type of fuel
		CurrentFuel	Information about the type of fuel currently burnt (read only)
		FuelSelect	Fuel selection via DOU when fuel selector is set to "Internal"
	SetClock		Setting the display of date
		Date	
		TimeOfDay	
	HoursRun		Displaying the current hours run readings
		GasFiring	Hours run gas (selectable)
		OilStage1/Mod	Hours run oil stage 1 or modulating (selectable)
		OilStage2	Hours run oil stage 2 (selectable)
		OilStage3	Hours run oil stage 3 (selectable)
		TotalHoursReset	Hours run total (can be reset)
		TotalHours	Hours run total (read only)
		SystemOnPower	Hours run device under voltage (read only)

	StartCounter		Displaying the start counter readings
		GasStartCount	Number of startups gas, start counter (selectable)
		OilStartCount	Number of startups oil, start counter (selectable)
		TotalStartCountR	Total number of startups, start counter (can be reset)
		TotalStartCount	Total number of startups, start counter (read only)
	Fuel Meter		Displaying the current counter readings
		Curr Flow Rate	Current fuel throughput
		Volume Gas	Fuel volume gas (read only)
		Volume Oil	Fuel volume oil (read only)
		Volume Gas R	Fuel volume gas (resettable)
		Volume Oil R	Fuel volume oil (resettable)
		Reset Date Gas	Reset date fuel volume gas
		Reset Date Oil	Reset date fuel volume oil
	LockoutCounter		Total number of lockouts that occurred (read only)
	O2 Module		
		Actual O2 Value	Actual O2 value
		O2 Setpoint	O2 setpoint
		SupplyAirTemp	Supply air temperature in °F
		FlueGas Temp	Flue gas temperature in °F
		CombEfficiency	Combustion efficiency
	BurnerID		Identification of burner
	OptgModeSelect		Operating mode selection of AZL5... for serial port and eBus
		InterfacePC	Setting the serial port (RS-232) of the AZL5... to interface operation for PC tool
		GatewayBASon	Activating the eBus port
		GatewayBASoff	Deactivating the eBus port
		Type of Gateway	
	O2Ctrl activate	O2 trim controller activated/deactivated	

Manual operation

User can scroll through and change manual operation settings from operating and display unit.

			Description
ManualOperation			
	SetLoad		Target load setting manually, percent of maximum load (%)
	Autom/Manual/Off		Select manual or automatic operation
		Auto	Burner capacity adjusts automatically controlled by capacity controller according to boiler temperature or pressure
		Burner on	Burner on manual operation according to SetLoad
		Burner off	Burner stopped

Logging in to system

To ensure burner operation, some functions and actuator settings can be adjusted only by trained service personnel. Password is needed when logging into system.

Password protected menu levels:

- Burner control
- Ratio control
- Servomotors
- Variable speed drive

Give password as follows:

1. Select Ss-password.
2. Give password.
3. Press **Enter**.

Burner Control menu level

- Times
- Configuration
- ProductID
- SW Version

Ratio Control menu level

- OilSettings
- Autom/Manual/Off
- Times
- ShutdownBehav
- ProgramStop

Servomotors

- Addressing
- DirectionRot
- SW Version
- ProductID

VSD Module

- Configuration
- Process Data
- ProductID
- SW Version

4.10 Adjusting operating and display unit settings

Scrolling menus

For scrolling and changing set values of the operating and display unit menu, use the four buttons on the panel.

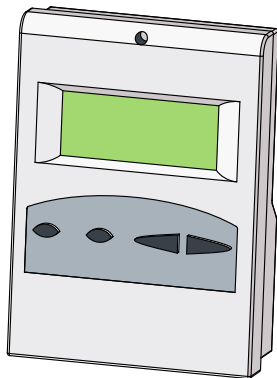

AZL ver. 4

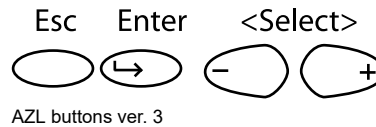

AZL buttons ver. 3

Scroll through the menus with the **Select -/+** buttons. Select the desired submenu by pressing **Enter**. Return to the higher menu level by pressing **Esc**.

Changing set values

1. Select **Params. & Display**.
2. Select the desired parameter.
3. Select a new parameter value using the **Select -/+** buttons.
4. Save the selected new value by pressing **Enter**.
5. Return to the menu by pressing **Esc**.

Adjusting display contrast

1. Press **Enter**.
2. Keep **Enter** pressed, and adjust the contrast using the **Select -/+** buttons.
3. Release **Enter** and return to the menu.

Activating safety check function

		Description
SafetyCheckFunct		
	LossFlameTest	Loss of flame test
	SLT test	Safety limit thermostat test



The burner lockout function can be triggered by pressing the **Enter** and **Esc** buttons simultaneously.

4.11 Variable speed drive settings and standardization (WD200)

The variable speed drive is used for fan motor control. The burner controller starts and stops the variable speed drive with a potential-free release contact. The VSD sends alarm data to the burner controller using a 12–24 V DC alarm signal. When active, the signal initiates a burner safety stop.

The burner controller controls the variable speed drive with a 0/4–20 mA signal. Variable speed drive operation must be linear.

Setting variable speed drive parameters

Set the variable speed drive parameters before the first start-up.

- Remove control signal filtering and delays.
- Set acceleration and deceleration time to 2 s.
- Set the minimum frequency to 0 Hz.
- Set the maximum frequency to 105.2% of the motor’s nominal speed.

After the variable speed drive parameters have been set, standardize the rotation speed.

Standardization

NOTICE

If automatic speed standardization is activated or a previously standardized speed value is edited manually, the burner must be readjusted.

Standardize the rotation speed after setting the variable speed drive parameters. Turn control selection switch S1 to position 1. The control voltage for burner automation (burner motor, servomotors) is switched on.

Access the necessary settings at the following menu level:

Params. & Display				
	VSD Module			
		Configuration		
			Speed	
				Num Puls per R
				Standardization
				StandardizedSp
				Setpoint Output
				Settling Time

<i>Num Puls per R</i>	Three pulses per round. Do not change the setting manually!
<i>Standardization</i>	automatic test for fan maximum rotation speed. Burner control should be in standby position when the test begins. Select <i>activated</i> from the menu to start the test. <ol style="list-style-type: none"> 1. The servomotor for air drives to pre-purge position. 2. The fan motor starts. 3. Burner control adjusts the variable speed drive setting to 95%. When the fan reaches a stable rotation speed, the measured speed will be set as the <i>StandardizedSp</i> value. This value is equal to 100% of fan rotation speed; 5% is reserved for changes in environmental conditions.
<i>StandardizedSp</i>	Do not change the setting manually! Perform standardization as described above.
<i>SettlingTime</i>	Rotation speed measured by variable speed drive control. With a stable output, the frequency measurement result stays almost the same. If the result varies notably, check sensor operation.
<i>Setpoint Output</i>	The variable speed drive control signal can be set to 0...20 mA or 4...20 mA.

4.12 Checking O₂ module (WD200)

O₂ module, connected to burner control through CAN bus, can be connected with oxygen sensor.

When control voltage is switched on, and oxygen sensor is activated, heating is on and oxygen sensor is ready for operation.

Activate oxygen sensor during first start-up, and always after power failure, to start heating. Oxygen sensor is ready for operation when 1292 °F is reached. It takes approx. 10 min to reach the temperature.

Oxygen sensor is self testing. Self test monitors aging of the device, based on measurement cell resistance and response time. If measurement cell resistance and response time exceed 400Ω and 25 seconds, self test gives an alarm, and sensor must be changed.

O₂ module settings are in the following menu level:

				Description
Params. & Display				
	O2 Module			
		Displayed Values		
			Actual O2 Value	Actual O2 Value
			O2 Setpoint	O2 Setting
			SupplyAirTemp	Supply air temperature in °F
			FlueGasTemp	Flue gas temperature °F
			CombEfficiency	Combustion efficiency

			QGO SensorTemp	QCO sensor temperature in °F
			QGO HeatingLoad	Control value of QGO... heating, 0,1%
			QGO Resistance	Internal resistance of QGO's Nernst cell

Self test is made at 23-intervals. Test requires constant O₂ level, for e.g. after pre-purge or on steady load. If constant O₂ level is not reached within 24 hours, burner control locks down operation load to reach constant O₂ level for next test. If burner is in stand by mode, test is made during next burner start-up.

NOTICE

Flue gases containing aggressive acids may considerably shorten the useful life of the oxygen sensor.

O₂ module can be connected with burner combustion air and flue gas temperature sensors. If sensors are connected, warning is displayed when flue gas temperature is too high, and combustion efficiency will be calculated and displayed.



Check that the oxygen value, sensor temperature, heating efficiency, and resistance values are displayed. If temperature sensors have been connected and activated, the values should be displayed.

4.13 Manual start-up and program stop in pre-purge position

Program stop

With the burner control *ProgramStop* parameter, the burner start-up can be stopped in selected program phase and servomotor position can be adjusted.

Pre-purge position	phases 24–34
Ignition position	phase 36
Transition 1	phase 44
Transition 2	phase 52
Post-purge	phases 72–78

Active program stop in phase 24.

Params & Display			
	Ratio Control		
		Program Stop	
			deactivated
			24 PrePurgP
			32 PreP FGR
			36 IgnitPos
			44 Interv 1

			52 Interv 2
			72 PostPPos
			76 PostPFGR

Manual start-up

Prerequisites:

- Variable speed drive parameters have been set and adjusted.
- Interlocks and failures have been reset.
- Program phase is 12, *Stand by*.

Activate manual burner start-up from the *Autom/Manual/Off* menu level by selecting *BurnerOn*:

ManualOperation		
	Autom/Manual/Off	
		Auto
		BurnerOn
		BurnerOff

Checking pre-purge position

Turn the burner control switch into position 2, *autom*. The burner starts if all prerequisites for start-up are fulfilled. The program phase proceeds 12...20...21, and so on and stops in phase 24. The message *Special position reached* appears on the display. The burner has reached the pre-purge position, and the servomotor positions can be modified if necessary. Configure the final pre-purge settings when the burner ignition load and curves have been set.

Params & Display					
	RatioControl				
		FuelSettings			
			SpecialPosition		
				PrepurgePos	
					Prepurge PosAir
					Prepurge PosAux1
					Prepurge PosAux2
					Prepurge PosAux3
					Prepurge PosVSD

When the curve point for full load has been set, adapt the point settings for the pre-purge position.

If a variable speed drive is in use, adapt its settings for pre-purge position.

If servomotors do not drive full motion at full load curve point, the burner start-up can be accelerated, because the servomotor running times remain shorter.

Gas use

- At full load air amount prepurge time is at least 20 s.
- 50% air amount prepurge time is at least 40 s.
- 33% air amount prepurge time is at least 60 s 33%.



- If you change the curve point setting for full load, apply the changes also to pre-purge position settings.
- Pre-purge must ventilate combustion chamber to fresh air level.
- If servomotor Aux 3 is in use, the servomotor does not move until phase 32 when program stop is changed to phase 32.

4.14 Ignition position

Set program stop at phase 36, *ignition*.

Burner control carries out automatic gas valve leak test during pre-purge, if:

- gas is selected as fuel, and it is the first start-up
- burner control has been unenergized
- it has been a long time from previous shutdown
- it is a start-up after safety shutdown or lockout reset

During standard stop, valve leak test is carried out before pre-purge period.

1. Servomotors drive to the ignition position. Set default values for ignition position. If oil is selected as fuel, check oil pump operating pressure.
2. When adjustments are set, select program stop at *44 Interval 1*. As the program moves forward, an electric arc is created. The pre-ignition phase begins. The pre-ignition phase is longer in oil use, so that purging period is implemented at nozzle to ensure good ignition. After the pre-ignition phase, the fuel nozzle opens and the flame ignites. Program progress is interrupted.
3. Optimize ignition position values. If gas is selected as fuel in program phase 44, only the ignition gas flame (if applicable) burns and in program phase 52, the main flame burns. If oil is selected as the fuel, the ignition is direct, and program phases have only different program phase durations. The ignition position setting can be adjusted in program stop phases 36, 44 and 52.
4. Select program stop *deactivated*. The burner shifts to standard operation, phase 60, to set minimum load. Ignition position settings become first curve point settings for fuel/air ratio curve, that can be changed.

Set ignition position settings at the following menu level:

Params & Display					
	RatioControl				
		GasSettings			
			Special Positions		

			↩	IgnitionPos	
				↩	IgnitionPos- Gas
					IgnitionPos- Air
					IgnitionPos- Aux1
					IgnitionPos- Aux2
					IgnitionPos- Aux3
					IgnitionPos- VSD



Check combustion values with ignition load using flue gas analysis.

4.15 Setting ratio curve

Curve points

There can be 15 curve points at the maximum.

Set curve points in the following menu level:

Params. & Display				
↩	RatioControl			
	↩	GasSettings		
		↩	CurveSettings	
			↩	Point
				Manual

Creating curve point individually

Current servomotor positions in degrees, variable speed drive control and capacity in percentages are shown on the right side of the display, starting from the top corner. The pointer is positioned at **Point**.

P o i n t		L o a d	:	2 3 . 5
	:	3		P - a
	:		:	2 3 . 2
O 2		A i r	:	4 1 . 6
4 . 5		A u x	:	3 3 . 3

Curve point 1 ver. 4

Press **Enter** to scroll through stored curve points.

```

P o i n t | L o a d      : 2 3 . 5
      : 3 | P - a        : 2 3 . 2
      O 2 | A i r       : 4 1 . 6
      4 . 5 | A u x     : 3 3 . 3
  
```

Curve point 2 ver. 4

The pointer is positioned at the colon below the text **Point**. The running number of the stored curve point is shown after the colon.

Curve points are stored according to capacity from smallest to biggest. Curve points can be added at any order. Scroll through curve points using the **Select +/-** buttons.

The setting for an unused curve point is XXXX and its running number is one number greater than that of the last stored curve point.

If you want to set a new curve point, press **Enter**, when XXXX is displayed as the set value.

The ignition position will automatically be set as the first ratio curve point, from which the burner minimum load point is adapted.

Editing individual curve point

To change an existing curve point:

1. Select the desired point and press **Enter**.
2. The pointer is positioned on **change?** below **Point**. The running number of the curve point to be changed is displayed after the colon.

```

P o i n t | P o i n t
      : 3 | c h a n g e ?
      M a n | d e l e t e ?
  
```

Curve point 3 ver. 4

3. Select the desired value using the **Select +/-** buttons, and press **Enter**.
 - **change** changes the curve point settings
 - **delete** deletes the curve point

Pointer positioned at **Load**.

```

P o i n t | L o a d      : 2 3 . 5
      : 3 | F u e l       : 2 3 . 2
      O 2 | A i r       : 4 1 . 6
      4 . 5 | A u x     : 3 3 . 3
  
```

Curve point 4 ver. 4



When the servomotors drive to position for a set curve point, the display shows “>” instead of “.”.

When the servomotors have reached their positions, “.” returns to the display.

Servomotor settings can be modified only when each servomotor has reached its position.

This operation can be interrupted by pressing **Esc**. The display returns to its initial state.

Capacity, servomotor and variable speed drive settings can be scrolled through using the **Select +/-** buttons.

P o i n t		L o a d	:	2 3 . 5
	:	3 F u e l	:	2 3 . 2
	O 2 A i r	:	4 1 . 6	
4 . 5 A u x	:	3 3 . 3		

Curve point 5 ver. 4

Press **Enter** at the desired parameter.

P o i n t		L o a d	:	2 3 . 5
	:	3 F u e l	:	2 3 . 2
	O 2 A i r	:	4 1 . 6	
4 . 5 A u x	:	3 3 . 3		

Curve point 6 ver. 4

Change setting using the **Select +/-** buttons. Then servomotors drive to their new position. During that time, the display shows “>” instead of “.”. Confirm the change by pressing **Enter** or undo by pressing **Esc**. Then you return to the previous menu level.

The servomotor turning angle is 0–90° and setting accuracy 0.1°. The capacity and variable speed drive setting range is 0–100% and they can be set at 0.1 % accuracy.

Adjust at point 1:

- burner minimum load, note ratio
- set fan rotation speed as small as possible, but not under 60%
- check combustion values with flue gas analysis
- check the combustion flame
- set load value and point load is determined according to current fuel consumption as a percentage of maximum load

In the settings for air servomotors and variable speed drive control, residual oxygen is adjusted as desired for each curve point.

When you have made changes, press **Esc**.

```

P o i n t
S t o r e - > E N T E R
C a n c e l - > E S C
    
```

Curve point 7 ver. 4

If you want to save the changes to curve point settings, press **Enter**. If you want to leave without saving changes, press **Esc**. After this, you will return to the point where you can scroll through curve points. Return to the menu by pressing **Esc**.

Creating curve point manually by changing load

1. At the menu level *CurveSetting*, move the pointer to *Manually*.

```

P o i n t | L o a d      : 2 3 . 5
          | F u e l     : 2 3 . 2
M a n | A i r         : 4 1 . 6
          | A u x       : 3 3 . 3
    
```

Curve point 8 ver. 4

2. Press **Enter**, and use the **Select +/-** buttons to increase or decrease burner start capacity.

```

    O 2 | L o a d      : 2 3 . 5
    4 . 5 | F u e l     : 2 3 . 2
M a n | A i r         : 4 1 . 6
2 3 . 5 | A u x       : 3 3 . 3
    
```

Curve point 9 ver. 5

3. Servomotors follow an imaginary linear curve towards the maximum or minimum load. The oxygen value can be monitored on the display. When increasing load, monitor that combustion values do not increase to a hazardous level. If necessary, set curve point for interval by pressing **Enter**, and correct servomotor positions to return combustion values to a normal level. Press **Esc** to return to the initial state. The curve point for maximum load will be set when fuel consumption for full load is reached.



Larger gas amount flow is reached when gas regulator valve angle is 62%. If gas consumption is not sufficient, check gas supply line control pressure and adjust if necessary.



If the required oil consumption is not reached when the oil regulator valve's setting is 90°, check the oil pump's operating pressure, and adjust if necessary.

Adjust at full load curve point:

- burner capacity, note ratio
- set fan rotation speed as small as possible
- check combustion values with flue gas analysis
- check combustion flame
- set point load setting at 100%

When you have made the required changes, save the maximum load curve point.



If the curve point for maximum load has an influence in the linear gas supply pressure, check the setting at the minimum point and adjust, if necessary.



If the curve point for maximum load has an influence in oil pump pressure, check the setting at the minimum point and adjust, if necessary.

Middle points are set manually by decreasing load manually for example at 10% intervals. Note that residual oxygen level is sufficiently over-aired if the burner is equipped with O₂ trim control. The residual oxygen level is set 1% higher than the normal level. There can be 15 curve points at the maximum. Set at least 10 curve points for O₂ trim control.



Measure fuel consumption at each adjusting point so that the set of curves correspond to the actual load conditions.



Check combustion values with ignition load using flue gas analysis.

When curve points have been set, exit from the curve setting menu level, and set the burner to operate at minimum load from manual operation menu level.

		Description
ManualOperation		
	SetLoad	
		Fixed load setting on manual operation, percentages of maximum load (%)

When exiting the **Params. & Display** menu level, changes can be stored to the operating and display unit memory.

Store changes by answering **yes**.



After adjusting burner maximum capacity, adjust the gas pressure maximum switch. See section *Adjusting gas pressure switch*.



After commissioning the burner, check air pressure switch settings. See section *Adjusting combustion differential air pressure switch*.

4.16 Activating FGR



Burners equipped with FGR can also be used without FGR. Whenever you activate and deactivate FGR, you will need to recheck fuel–air ratio curves.

FGR can be activated from: **Params. & Display** → **Flue gas recirc.** → **FGR mode** → **TC autodeact** →

It is recommended to commission the plant first without flue gas recirculation (FGR). Thus the fuel-air ratio control system is set as if the plant operated without the FGR function.

When all other settings have been made, create FGR curve points at ratio curve. The FGR function will become active after you have stored the curve point settings.

During the time the curve menu is in use, the state of the FGR function does not change. This means that the AUX3 for FGR is still at the **FGR closed** position until parameter setting is completed.

The parameters for FGR mode have been set at the factory. The commissioning personnel will adjust the settings at start-up if needed.

For further instructions, see the section *Setting FGR curve points*.

4.17 Setting FGR curve points

The FGR curve points are set at the fuel-air ratio curve. During the time the curve menu is in use, the state of the FGR function does not change. This means that if the AUX3 is still at the **ignition position** when setting parameters, it maintains the position until the curve setting is completed.

At this position, the recirculation duct remains in **ignition position**, and the AUX3 is marked with **#** on the screen. The position value of the AUX3 can be changed, but it will not follow the readjustment for that period of time. The changed value can also be stored.

If the AUX3 is not marked with **#** when setting parameters, it is already on the ratio control curve, and follows the readjustment of the position value immediately.

After time period or temperature is reached, AUX3 will be released and FGR curve can be made.

Temperature value can be changed from: **Params. & Display** → **Flue gas recirc.** → **ThresholdFGR Gas** →

Time period value can be changed from: **Params. & Display** → **Flue gas recirc.** → **DelaytimeFGR Gas** →

To create curve points:

1. Go to **Params. & Display** → **Ratio control** → **Gas settings** → **Curve Param** →
2. Select the required curve point and press →.
3. To edit the curve point, select **change**, and press → to continue.

```

P o i n t | P o i n t
      : 3 | c h a n g e ?
M a n | d e l e t e ?
    
```

Curve point 3 ver. 4

4. Select should the servomotors follow the adjustment during operation, **Followed** or **Not followed**.
5. On the next screen, press **Enter** to continue.

```

P o i n t | L o a d      : 2 3 . 5
      : 3 | F u e l      : 2 3 . 2
      0 2 | A i r       : 4 1 . 6
      4 . 5 | A u x 3   : 3 3 . 3
    
```

Curve point 3 FGR ver. 1

FGR temperature is stored to each curve point. Current FGR temperature can be viewed from display using +/- buttons.

Make sure capacity is stable and FGR temperature is within the normal operation limits before storing curve point. This temperature is used to module the FGR valve during operation.



Changing curve settings may have an impact on the combustion settings. Check the servomotors regulating fuel and air. Readjust if needed.

You can save changes to the operating and display unit memory. Answer **yes** to the screen message that appears when leaving **Params. & Display** menu level.

For more detailed instructions on setting, monitoring, and editing curve points, see section *Setting ratio curve*.

4.18 Measuring FGR

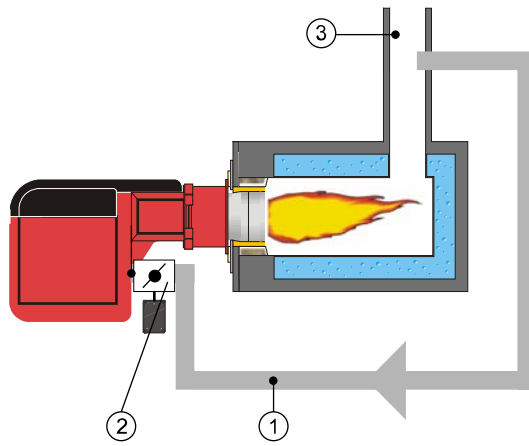

FGR principle monoblock ver. 3

Pos.	Item
1	FGR duct
2	FGR control valve
3	Measuring point of residual oxygen in flue gas

Recirculated flue gas amount is typically 5–20 % of the flue gas/combustion air mixture amount, depending on the application. Flue gas percentage is counted as follows:



$$\text{FGR \%} = \frac{\text{Flue gas amount recirculated ppm}}{(\text{Flue gas amount recirculated ppm} + \text{combustion air amount in ppm})} \%$$

To define flue gas percentage

1. First measure the amount of O₂ in the flue gas/combustion air mixture. The optimal measuring point is the burner wind box.
2. Measure the residual O₂ in flue gas.
3. Read the FGR percentage value in the diagram below.

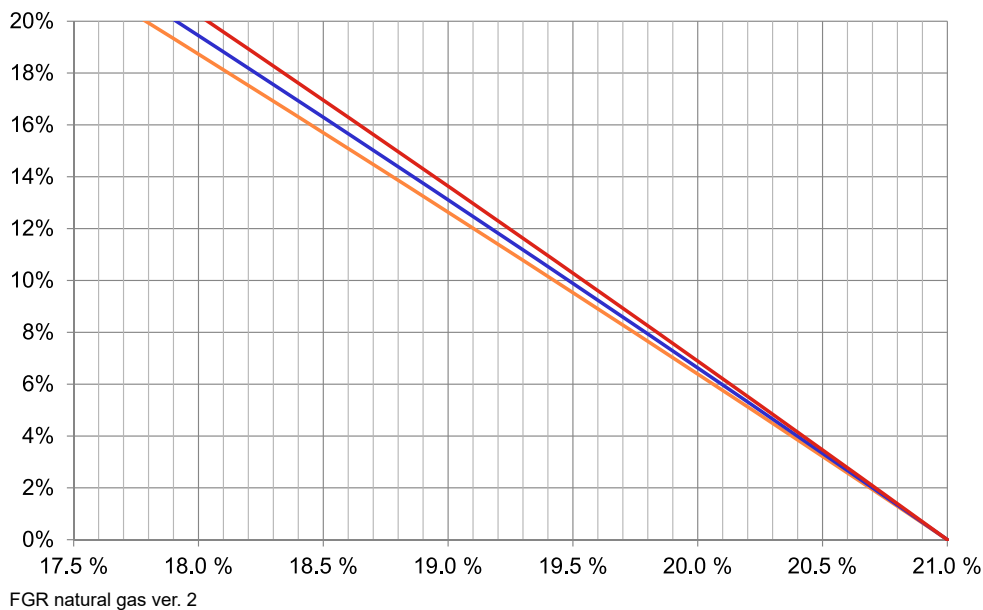
Natural gas combustion, flue gas recirculation (%)



	Flue gas O2 = 2%
	Flue gas O2 = 3%
	Flue gas O2 = 4%



Y axis: FGR, %, X axis: Mixture O2 content (dry), %.

NOTICE	FGR may cause unstable combustion. To avoid noise, vibration or other disturbance, the settings must always be defined for each burner separately.
---------------	--

4.19 Capacity range

Burner capacity range can be set as required at service level. The minimum capacity can be greater than the first curve point, and the maximum capacity can be below the last curve point. During start-up, the burner runs from ignition capacity to minimum capacity and continues to normal operation. Ignition capacity can be greater, smaller, or equal to the first curve point capacity.

In the menu, set the minimum and maximum capacity individually for each fuel:

					Description
Params. & Display					
	RatioControl				
		GasSettings			

			LoadLimits		
				MinLoadGas.	Minimum load "Low fire" (gas)
				MaxLoadGas	Maximum load "High fire" (gas)

At the user level, maximum load can be set individually as follows:

			Description
Operation			
	User Maxload		
		User MaxLoadMod	Maximum load on modulating burner

4.20 O2 min. value control (WD200)

O2 ratio control can be set after setting the ratio curve.

NOTICE

Ratio curve air amount should be approx. 1% higher than O₂ ratio control, so that environmental changes do not set residual oxygen level below O₂ trim control level.

Ratio curve should be as smooth as possible. If the curve has sharp breakpoints, set one additional point to smooth the curve. Even ratio curve improves O₂ ratio control. In dual-fuel burners, set the O₂ ratio control individually for both fuels, and they are not correlating.

Start O₂ ratio curve by setting O₂ min. value control.

O2 min. value control

When setting for the first time O₂ monitor should be deactivated with *man deact*.

Params. & Display				
	O2Contr/Guard			
		FuelSettings		
			OptgMode	
				man deact

Set O₂ min. value control as low as possible to ensure a high availability. O₂ min. value is between the permanently non-hazardous range and the potentially hazardous range. O₂ ratio curve is set at lowest 0.5 %–1 % above O₂ min. value, so during normal burner operation this level should not be reached.

NOTICE

Hazardous conditions must not permanently occur above or at O₂ min. value.

Maximum permitted values: CO = 4000 ppm, #2 on the Shell-Bacharach scale.

Values may vary depending on the type of the configuration.

NOTICE

If you change the ratio curves at a later date, the minimum value must also be readjusted.

O2 min. value direct entry

1. Select *O2 Monitor* from menu as follows:

Params. & Display			
↩	O2Contr/Guard		
	↩	Fuel Settings	
		↩	O2 Monitor

2. If the limit values of a plant are known, O2 min. values can be entered directly to curve points during burner operation.
The first line shows curve point number. Scroll through points by pressing the **Select -/+** buttons. By pressing **Enter** twice, you can enter residual oxygen level as percentages to the second line. Use the **Select -/+** buttons.

```

P o i n t : 2
O 2 - M i n V a l u e : 1 . 2
P - A i r M a n : 0 . 0
    
```

Point26 ver. 4

3. Accept the value by pressing **Enter**. Exit by pressing **Esc**.

Measuring O2 min. values by reducing air

1. Select desired point from previous menu level by pressing the **Select -/+** buttons during burner operation. Press **Enter**.
2. Select third line *P-Air Man* by pressing the **Select -/+** buttons, and press **Enter**. The display changes as follows:

```

P o i n t : 2
A c t o 2 V a l u e : 1 . 2
P - A i r M a n : 1 2 . 9
    
```

Point27 ver. 4

3. Second line shows residual oxygen level. You can reduce air by pressing the **Select -/+** buttons. Larger value at *P-Air Man* means larger air throttle.
O2 min. value surface is verified by throttling air and measuring CO level at the same time.
4. When desired oxygen level is reached, accept the value by pressing **Enter**. Exit by pressing **Esc**. Repeat for each curve point.

Start setting O2 ratio control after O2 min. value control is set.

4.21 Setting O₂ trim control (WD200)

O₂ min. value *O2Control* must be set first.



It is important that environmental conditions do not change when setting O₂ trim control.

NOTICE

If you change the curves at a later date, O₂ trim control must also be adjusted.

The first curve point from which O₂ trim control begins is preset at curve point 2. That is the first point to be set for O₂ trim control. At this point burner control calculates low capacity settings for O₂ trim control. At lower capacity burner operates according to ratio curve, without O₂ trim control.

1. Select *O2 Control* from the following menu level:

Params. & Display			
	O2Contr/Guard		
		Fuel Settings	
			O2 Control

2. The first O₂ trim control point is curve point 2.
At lower capacity burner operates according to ratio curve.
Confirm the selection by pressing **Enter**. The burner runs to point 2 capacity.

```

P o i n t : 2
O 2 - R a t i o C o n : X X X X
O 2 S e t p o i n t   : X X X X
S t a n d v a l       : X X X X
    
```

Point2 ver. 4

3. The display changes. The second line *O2ratioCon* shows current residual oxygen level. Wait until the level stabilizes, and corresponds with ratio curve level. The burner control uses this level when calculating O₂ trim control settings.
Confirm the selection by pressing **Enter**.

```

P o i n t : 2
O 2 - R a t i o C o n : 5 . 4
I f V a l u e S t a b l e
C o n t i n u e W E n t e r
    
```

Point22 ver. 4

- The display changes. The third line shows the current residual oxygen level. The pointer is on *StandardVal*. Reduce the air by pressing the **Select -/+** buttons, if necessary. A larger number at this point means larger without air throttle. When desired oxygen level is reached, press **Enter**.

```

P o i n t : 2
O 2 - R a t i o C o n : 5 . 2
O 2 - S e t p o i n t : 2 . 0
S t a n d V a l : 1 2 . 3
    
```

Point23 ver. 4

- The display changes.

Save or reject by pressing **Enter** or **Esc**.

```

P o i n t
S t o r e - > E N T E R
C a n c e l - > E S C
    
```

Point24 ver. 4

At curve point 2, and at the highest curve point, the burner control calculates PID parameters, and time delays for O₂ monitor by driving the burner back to ratio curve. After that the display returns to initial state.

Select next curve points from the menu by pressing the **Select -/+** buttons, and set O₂ setpoints from them. If flue gas speed in ratio curve point 2 is too low, O₂ monitoring set value calculation does not succeed. The burner control notifies this in the operating and display unit.

O₂ monitoring first point can be set later using the parameter *Adapt.Pointsmall*.

```

D e l a y t i m e i s
m e a s u r e d
O 2 s e t p o i n t : 2 . 5
    
```

Point25 ver. 4

4.22 O₂ trim control operating mode (WD200)

Select the suitable O₂ trim control operating mode as follows:

Params. & Display				
	O2Contr/Guard			
		FuelSettings		
			OptgMode	
				auto deact
				man deact
				O2 Limiter
				O2 Control
				conAutoDeac

O2 trim control operating modes

<i>man deact</i>	Use this setting when creating O2 ratio curve. Both <i>O2Limiter</i> and <i>O2Control</i> are deactivated. Burner operates according to parameterized ratio curves.
<i>O2 Limiter</i>	Only <i>O2Limiter</i> is active. Oxygen sensor must have reached its operating temperature. If not, start-up will be prevented. If oxygen sensor or O2 module causes a failure during burner operation, burner stops, tries to restart or lockout occurs.
<i>O2 Control</i>	Both <i>O2Limiter</i> and <i>O2Control</i> are active. Oxygen sensor must have reached its operating temperature. If not, start-up will be prevented. If oxygen sensor or O2 module causes a failure during burner operation, burner stops, tries to restart or lockout occurs.
<i>conAutoDeac</i>	Use this setting during normal operation. Both <i>O2Limiter</i> and <i>O2Control</i> are active. Burner starts, though oxygen sensor has not reached its operating temperature. Burner operates along parameterized ratio curves. When oxygen sensor has reached its operating temperature and sensor test has been successfully completed, both <i>O2Limiter</i> and <i>O2Control</i> are active. If oxygen sensor or O2 module cause failure during burner operation, both <i>O2Limiter</i> and <i>O2Control</i> are deactivated. Burner operates along parameterized ratio curves. O2 trim control status in operating and display unit is automatically set to <i>auto deact</i> , and error code is displayed. Error code is maintained until O2 trim control is manually deactivated or activated.
<i>auto deact</i>	O2 trim control has automatically been deactivated and burner operates along parameterized ratio curves. Do not select this option!



If O2 trim has been automatically deactivated, then you can reactivate it from: **Operation** → **O2Ctrl Activate** → **Activate** →.

4.23 O₂ trim control load limitation (WD200)

Select *O2CtrlThreshold* from the operating and display unit menu as follows:



Params. & Display			
	O2Contr/Guard		
		Fuel settings	
			O2CtrlThreshold

			Apadt.Point small
			Type of Fuel
			Fuel user def

If load drops below this limit, the burner operates along parameterized ratio curves without O₂ trim control. Set load limitation after setting O₂ trim control ratio curve. Load limitation is usually curve point 2 load from basic parameterized ratio curve.

4.24 O₂ trim control when load changes (WD200)

When load changes under unfavourable setting conditions, the actual O₂ value will drop below the minimum limit. To prevent this, parameterize an increase of the O₂ value during capacity change *O2 OffsetGas/Oil*.



Params. & Display			
	O2Contr/Guard		
		FuelSettings	
			Type ofAir-Change
			O2 OffsetGas/Oil
			LoadCtrlSuspend
			FilterTimeLoad

Parameters

<i>Type ofAirChange</i>	Impact of air density change on O ₂ value <ul style="list-style-type: none"> • like P air, gas use • like theory, oil use
<i>O2 OffsetGas/Oil</i>	O ₂ trim control setting increase during capacity control. Presetting 0.5%.
<i>LoadCtrlSuspend</i>	Limit of load difference when O ₂ trim controller will be locked. Presetting 5%.
<i>FilterTimeLoad</i>	Delay time of previous parameter, 5 => 5 x τ, presetting.

4.25 Setting capacity controller operating mode

1. Set the boiler temperature setpoint W1 for the capacity controller as follows:

			Description
Operation			
	BoilerSetpoint		
		SetpointW1	Internal setpoint W1, °F Internal setpoint W1, PSI

2. Start the burner manually by setting the *Autom/Manual/Off* option to *Autom*. The preset value from burner control is IntLC.

ManualOperation		
	Autom/Manual/Off	
		Autom Burner on Burner off

3. Burner control capacity controller keeps boiler temperature or pressure constant by changing burner capacity as necessary. The capacity controller shuts down and restarts the burner as necessary. Select the control parameters for the capacity control from the menu as follows:

Params. & Display			
	Configuration		
		LC_OptgMode	
			ExtLC X5-03 IntLC IntLC Bus IntLC X62 ExtLC X62 ExtLC Bus

Capacity controller operating modes:

<i>ExtLC X5-03</i>	External capacity controller with contactors.
<i>IntLC</i>	Internal burner control capacity controller. Internal set value W1 in use. Can be changed to internal set values W1 and W2 using contactors.
<i>IntLC Bus</i>	Internal burner control capacity controller. Set value for burner control through Modbus or eBus.
<i>IntLC X62</i>	Internal burner control capacity controller. Set value for burner control through analog signal. Can be changed to internal set value W1 using contactors.
<i>ExtLC X62</i>	External capacity control with analog signal.
<i>ExtLC Bus</i>	External capacity control using Modbus or eBus.

4.26 Setting load controller parameters

Standard parameter setting

Load controller contains 5 standard parameter settings that can be selected and activated, depending on characteristics of controlled process.

Params. & Display					
	Load- Controller				
		Controller-Param			
			ContrlParam-List		
				Standard-Param	
					Adaption

					very fast
					fast
					normal
					slow
					very slow

Standard parameters are listed in the following table:

	Proportional band [%]	Integral action time [s]	Derivative action time [s]
Very fast	42.5	68	12
Fast	14.5	77	14
Normal	6.4	136	24
Slow	4.7	250	44
Very slow	3.4	273	48

Setting parameters individually

PID parameters can also be set individually according to the following value range:

- *P-Part (Xp)* 2...500% of the measurement range
- *I-Part (Tn)* 0...2000s, 0=no I part
- *D-Part (Tv)* 0...1000s, 0=no D part

Params. & Display				
	LoadController			
		ControllerParam		
			ContrlParamList	
				P -Part (Xp)
				I -Part (Tn)
				D -Part (Tv)

- By increasing the proportional band, the temperature/pressure deviation is lowered. Using too great a proportion will result in temperature/pressure fluctuation.
- The integral action time defines the time that it takes for the temperature/pressure deviation to return back to zero.
- The derivative action time speeds up control. Set the P and I parts while the value for the D part is 0.
- Using too great a derivative action time will result in temperature/pressure fluctuation.

Parameter adaptation

During adaptation, the burner control calculates PID parameters for process which is controlled based on the characteristics.

Params. & Display			
↶	LoadController		
	↶	Adaption	
		↶	StartAdaption
			AdaptionLoad

The burner and boiler must be ready for 10 min. run, where boiler temperature or pressure is dropped to 5 % below set value, and then run with full load. This occurs automatically according to the following diagram. Boiler load should stay constant throughout adaptation.

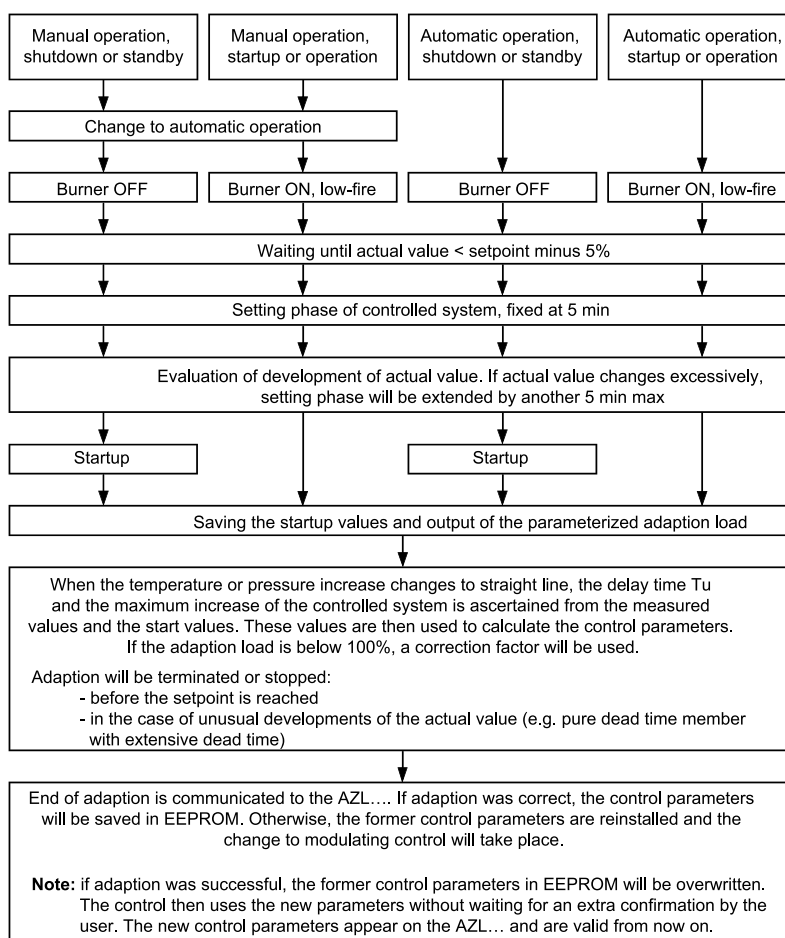

Flow chart_WD capacity ver. 3

O₂ trim control must not be active during adaptation.

In the WD200 system, deactivate O₂ trim control from the operating and display unit menu:

Operation		
↶	O2Ctrl activate	
	↶	deactivated
		activated

Select *StartAdaption*.

Parameter evaluation

Load control does not cause variation in boiler temperature or pressure with optimum PID parameters.

When changing the setting, boiler temperature or pressure should stabilize without going up and down. Pressure and temperature must not go under or exceed set values.

A common ratio for $Tn / Tv = 4...6$.

Examples of typical incorrect settings, and the optimal setting to change the set value:

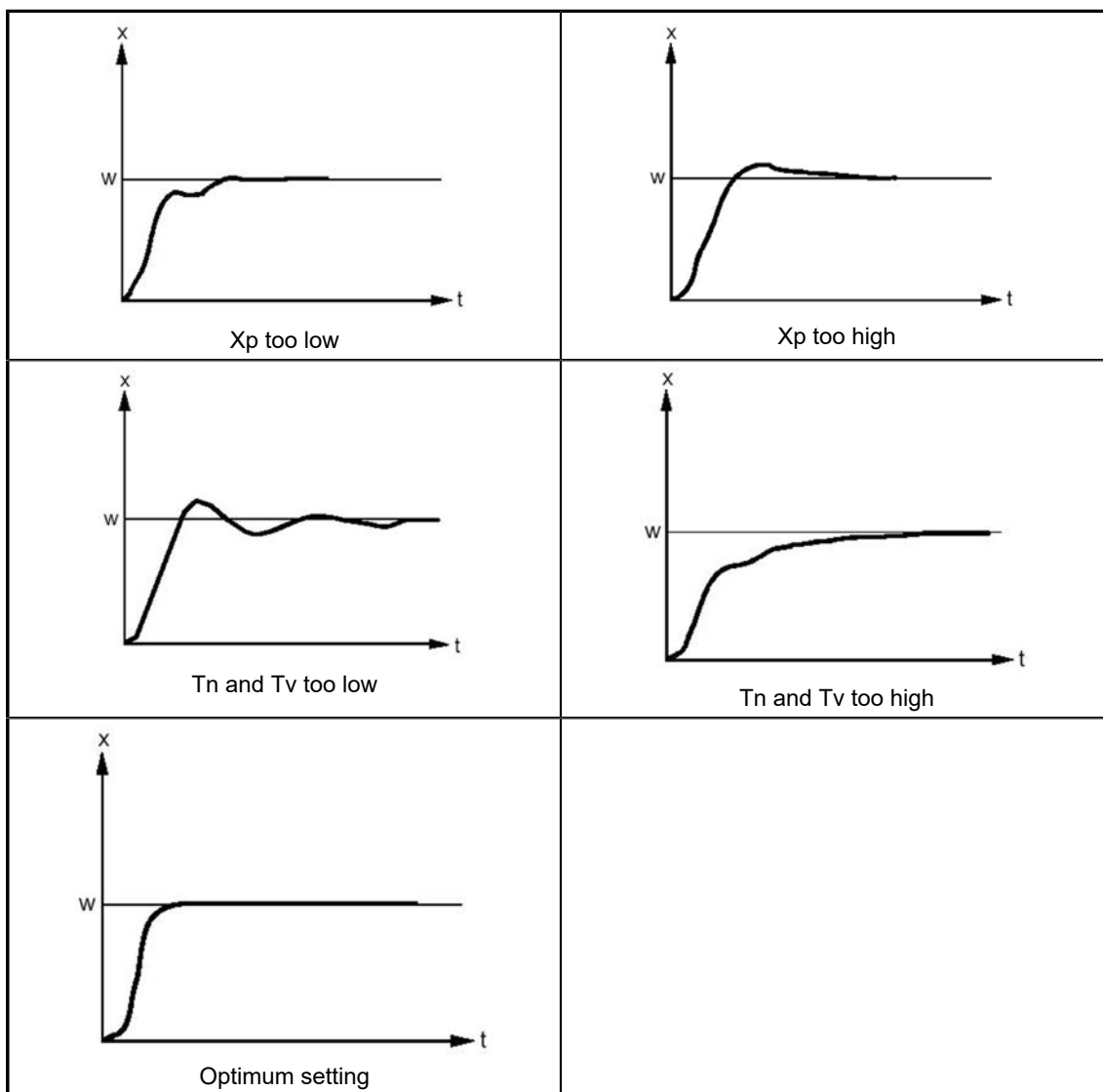

If load control is not completely stabilized, but fluctuates continuously near the setpoint value, the following parameters can be used to control this.



Always make sure that the PID parameters are correctly set before using the following parameters. A noticeable fluctuation of load near the set value indicates poor setting of PID parameters.

Params. & Display			
↶	LoadController		
	↶	ControllerParam	
		↶	MinActuatorStep
			SW_FilterTimeCon

MinActuatorStep is the minimum possible actuator step. This affects the load controller accuracy but may stabilize its action. If the value for this parameter is too high, the load control becomes unstable. The factory setting is 1%.

SW_FilterTimeCon. can be used to delay the internal load controller. If the value for this parameter is too high, the internal load controller becomes unstable. The factory setting is 3s.

4.27 Capacity controller on/off

If temperature or pressure has been given a set value, burner start-up and shut down limits are percentages of the set value. Calculate switching points according to following example:

	Setting	158 °F
Mod_On	Burner start	-10% (=44.6 °F) 158 — 44.6 = 113.4 °F
Mod_Off	Burner shutdown	+5 % (=38.3 °F) 158 + 38.3 = 196.3 °F
Mod_On	is possible to set between	-50...+50 %
Mod_Off	is possible to set between	0...+50 %

Params. & Display			
↶	LoadController		
	↶	ControllerParam	
		↶	Mod_On
			Mod_OFF

Example running period.

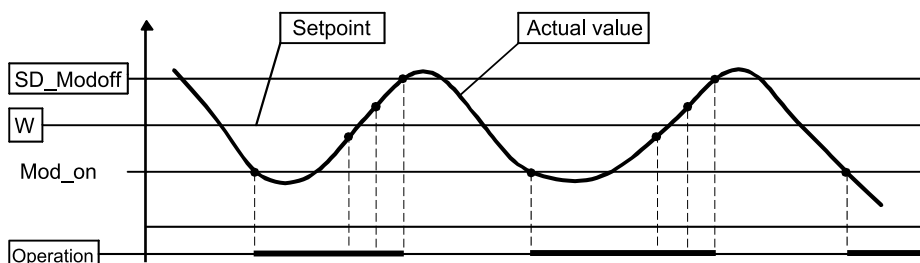

Operation phase ver. 3



4.28 Boiler temperature limiting with burner control

Boiler temperature can be limited with burner control. It can be implemented with the same sensor used for temperature control, or with a separate sensor. When pressure control is selected, temperature limiter is not in use.

If limiter temperature switch-on point is reached, burner shuts down. Burner restarts when temperature limiter is reset.

Example:

<i>TL_ThresholdOff</i>	Limiter switch-on point	176 °F
<i>TL_SwiDiff_On</i>	Temperature difference percentages	-10 % (46.4 °F)
	Limiter reset temperature	161.6 °F

				Description
Params. & Display				
	LoadController			
		TempLimiter		
			<i>TL_ThreshOff</i>	Temperature limiter OFF threshold, °F
			<i>TL_SD_On</i>	Temperature limiter switching differential ON

4.29 Cold start thermal shock protection

Cold start thermal shock protection protects the boiler from thermal stress if the boiler has cooled down. The burner starts with small load and the load increases as the boiler warms up. Without protection, the burner runs straight to full load.

If boiler temperature or pressure has dropped under set value *ThresholdOn*, the burner starts with minimum load. The load depends on two factors:

1. If the set value does not reach the set step within the maximum time, the load will be increased by one stage step.
2. If the set value has reached the set step before the maximum time has elapsed, the load increases by one stage step.

The menu shows values used in the chart example.

				Example, Set value 145 PSI
Params. & Display				
	LoadController			
		ColdStart		
			<i>ColdStartOn</i>	activated

		ThresholdOn	40% of set value
		StageLoad	15% load step
		StageSetp_Mod	10% of set value
		StageSetp_Stage	
		MaxTmeMod	5 minutes
		MaxTmeStage	
		ThresholdOff	80% of set value
		AdditionalSens	
		Setp AddSensor	
		Release Stages	

Cold start thermal protection operation example.

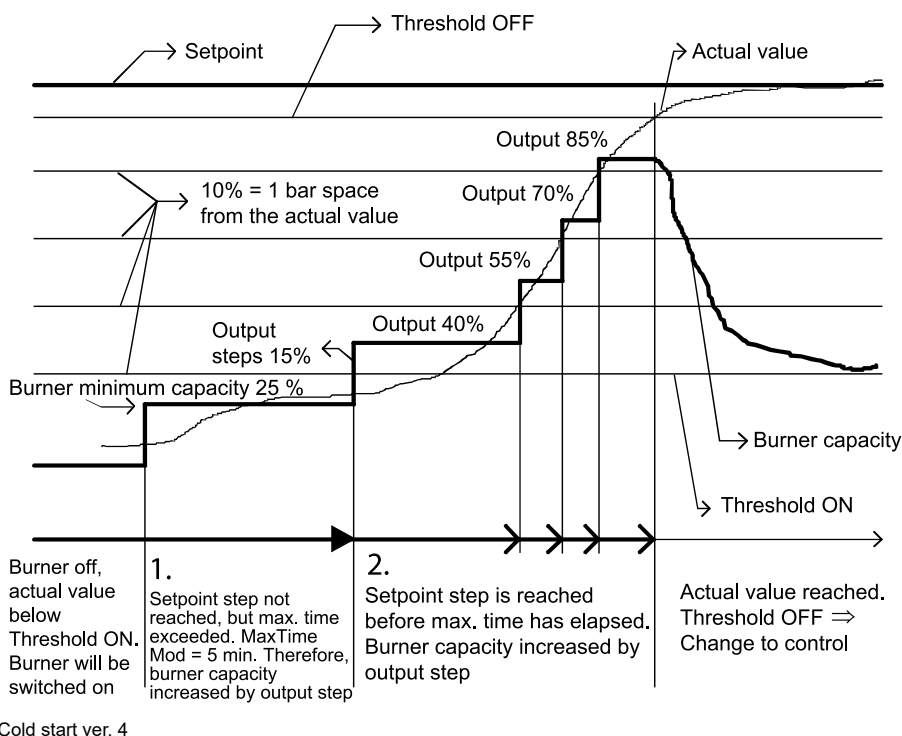

4.30 Measuring flue gas and combustion air temperature (WD200)

Flue gas and combustion air temperature measuring sensor can be connected to O₂ module.



Select the sensor type and set the alarm threshold from the menu as follows:

Params. & Display			
↶	O2 Module		
	↶	Configuration	
		↶	O2 Sensor
			SupAirTempSens

			FlueGasTempSens
			MaxTempFIGasGas
			MaxTempFIGasOil



4.31 Activating O₂ trim control (WD200)

At the end of commissioning activate O₂ trim control from the display and operation unit menu.

Operation		
	O2Ctrl activate	
		deactivated activated

4.32 Backing up parameters

1. Start backing up parameters by selecting the following from the display and operating unit:

Updating		
	ParamBackup	
		BackupInfo
		LMV5x -> AZL
		AZL -> LMV5x

2. Start backing up by pressing **Enter**.
3. Parameter backup is done when the text *Parameters saved* appears on the display.

5 Operation

5.1 WiseDrive system

WiseDrive 100 / 200

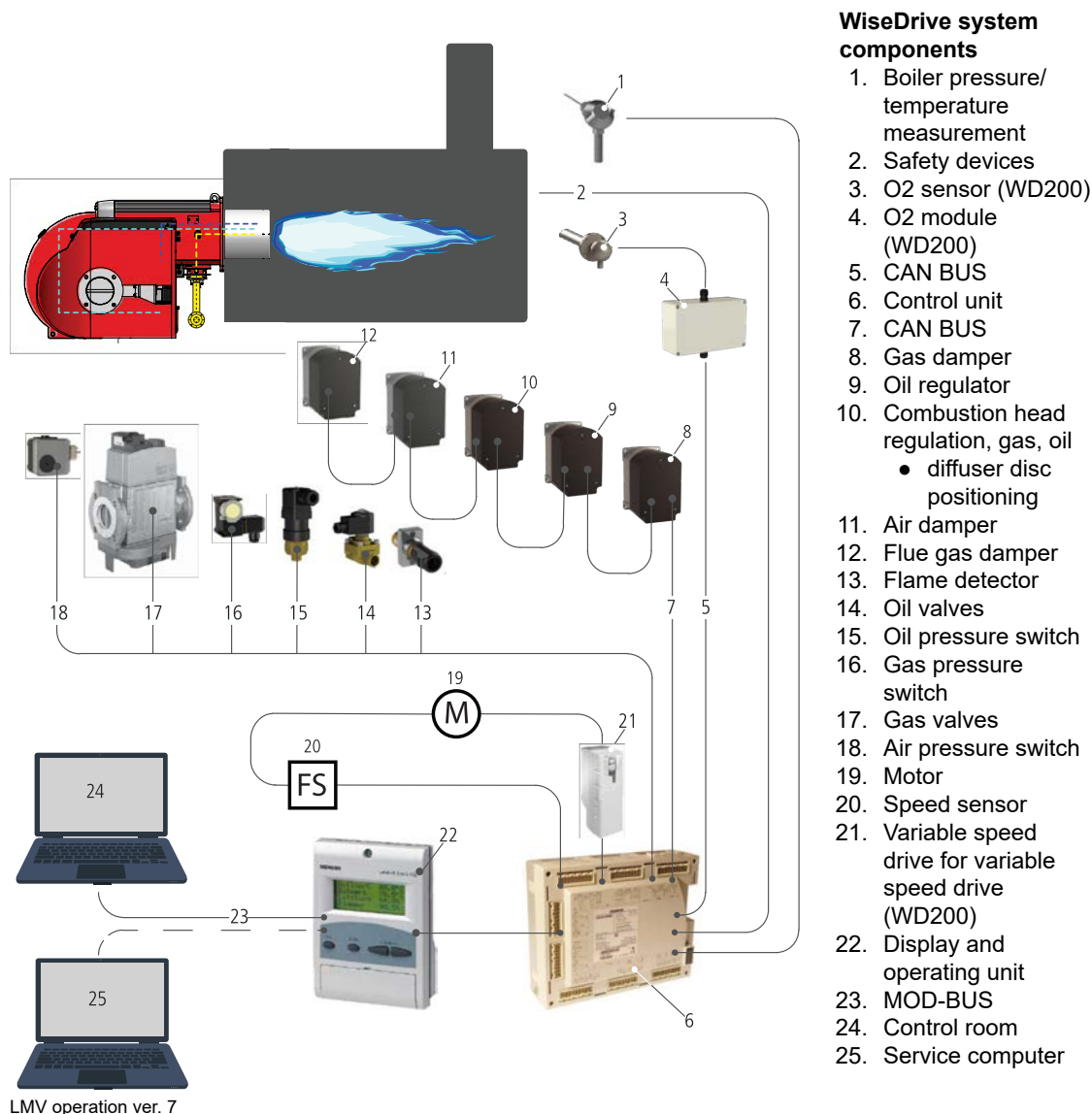

The assembly may vary depending on the scope of delivery.

In the WiseDrive system, burner operation is controlled and supervised by a separate burner controller.

In the WD200 system, the burner can be equipped with an O₂ module to increase combustion efficiency.

The burner control adjusts the burner's fuel and air ratio as well as solenoid valves.

The system includes an operating and display unit for local use. A remote PC application can be used during commissioning and servicing.

To enable continuous operation, the WiseDrive system uses components designed specifically for this system. The system supervises components related to safety functions with continuous self-testing.

Burner control

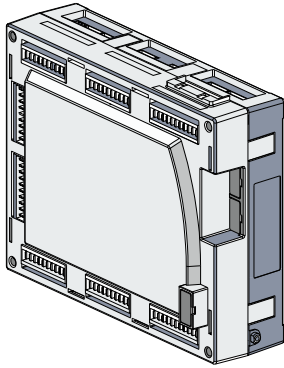

LMV5 ver. 3

Burner controller is a microprocessor-based burner control and safety system.

Burner control can have the following features:

- Burner control and safety functions
- Electronic fuel/air ratio
- Gas valve proving
- Capacity controller
- Fan variable speed drive control (WD200)
- Residual oxygen control (WD200)
- Boiler cold start thermal shock protection
- Fuel flow meter (WD200)
- Burner efficiency measuring (WD200)
- Start-up and running time counters
- Fault and lockout history
- Real-time clock
- Bus interface



The burner controller is a safety device. Do not open the unit or interfere with its operation.

Servomotors

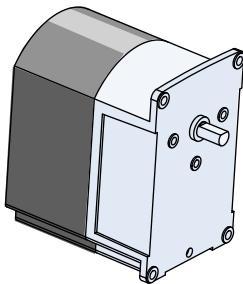

SW00017 ver. 3

Servomotors are used to drive fuel regulators and other actuating devices.



- Electrostatic discharge can cause damage to the servomotor.
- Do not dismount the servomotor.
- Do not modify the unit or any connected equipment or interfere with its operation. This could damage the servomotor or change burner settings.
- Never use a servomotor that you think might be damaged.

Combustion air

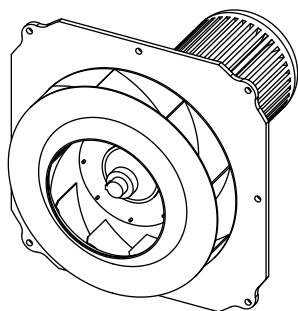

Fan (300 - 700) ver. 3

Combustion air provides the needed air pressure and volume for efficient combustion. In the WD200 system, the fan motor can be fitted with a variable speed drive. The variable speed drive adjusts air pressure according to burner's capacity by controlling the fan speed.

Operating and display unit

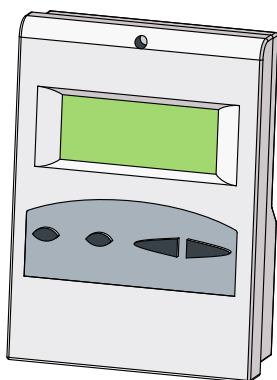

AZL ver. 4

The WiseDrive system operating and display unit is used for monitoring and adjusting settings. The menu is available in several languages. The operating and display unit has an internal memory backed up by a battery. The memory stores the burner control parameters. Battery durability is approximately 10 years.

O2 module (WD200)

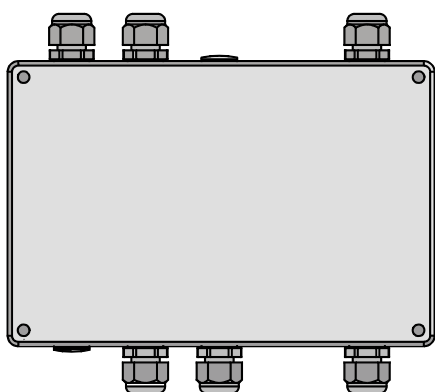

PLL52 ver. 3

O2 module and oxygen sensor measure the residual oxygen content of the flue gases. Burner control uses the measurements to monitor and optimize the combustion process. Flue gas and combustion air temperature sensors can be connected to the system to measure efficiency.

Oxygen sensor (WD200)

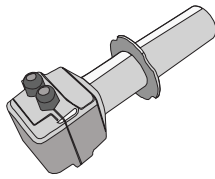

QG020 ver. 3

Oxygen sensor measures the amount of residual oxygen from flue gas. The sensor is a ceramic zirconium dioxide cell and self-testing.

Flame detector

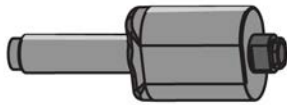

QRI ver. 3

QRI is a flame detector for use with gas, oil and other flames that emit infrared light. Flame signal intensity can be monitored on display. Flame detector is equipped with self-test function and is suitable for continuous operation.

5.2 Control panel



The control panel illustration below is only an example. Check the exact layout from electrical drawings.

WDx00

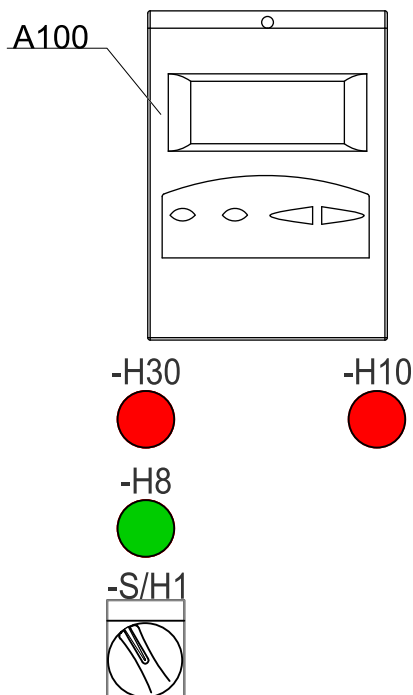

Control panel GP ver. 4

A100	Operating and display unit
S/H1	Control switch with pilot light
H8	Gas flame
H10	Boiler failure
H30	Burner failure

Control switch















Switch position	State
0 - STOP	Burner start-up by control devices is prevented. If the switch is turned to the '0' position while the burner is running, a controlled shutdown is initiated. The green indicator light on the switch indicates that the control voltage for burner automation (burner control, servomotors) is switched on.
1 - RUN	When a start signal is received from a control device, the burner starts. The burner control start-up program begins. The burner operates controlled by the capacity controller or at a manually preset load. Burner control supervises burner operation and performs a controlled shutdown or, if necessary, a safety shutdown and lockout.
R - RESET	Burner failures are reset.

Signal lamps

Signal lamp	State
H8	Gas flame: the light is on when the main gas valves are open.
H10	Boiler failure: the light is on when the boiler safety loop is open and lockout is active.
H30	Burner failure: the light is on when a failure has occurred in burner operation and lockout is active.

5.3 Legend to PI diagrams

	Valve		Firing system, burner
	Non-return valve		Filter
	Regulator		Differential pressure switch
	Shutoff valve		Flame detector
	Compound regulator		Pressure switch, low
	Air dampers		Pressure switch, high
	Butterfly valve		Gauging position switch
	Oil pump		Pressure indicator

	Oil pressure regulator		Motor
	Fan		Flame arrester
	Ball valve		Pneumatic shut-off valve
	Solenoid valve		Safety valve
	One way valve		Pressure regulator
	Adjustable valve		Mesh
	Valve open softener		Orifice

5.4 Burner operation and PI diagram, gas

Combustion air

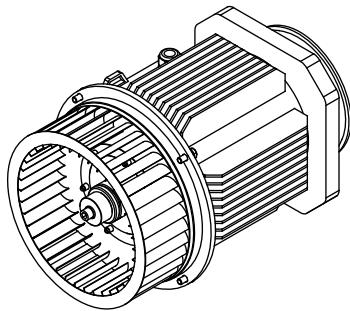

Fan (50 - 280) ver. 1

The burner is equipped with a fan which is designed to produce consistently high air pressure. This is required for flawless ignition and good combustion in modern combustion chambers. A servomotor controls the air volume according to fuel combustion.

Pre-purge and ignition

After the pre-purge, the servomotors run to ignition position, the ignition begins and ignition gas valves open. Gas is released to the nozzle and ignited by an electric arc. After the first safety time, both fuel valves open and the ignition flame ignites the main flame.

Gas valve proving

Gas valve proving is carried out by a pressure switch that tests the double solenoid valve and ignition gas valve tightness according to the burner control program phase. The pressure switch carries out gas valve testing during controlled shutdown or during the next pre-purge period.

Burner operation

During burner operation, the control unit adjusts servomotors according to capacity controller inputs. Servomotors adjust the gas regulator valve and air dampers between partial load and full load according to the capacity demand.

Burner shutdown

If the current partial load exceeds the capacity demand, the burner shuts down and the double solenoid valve closes.

PI diagram

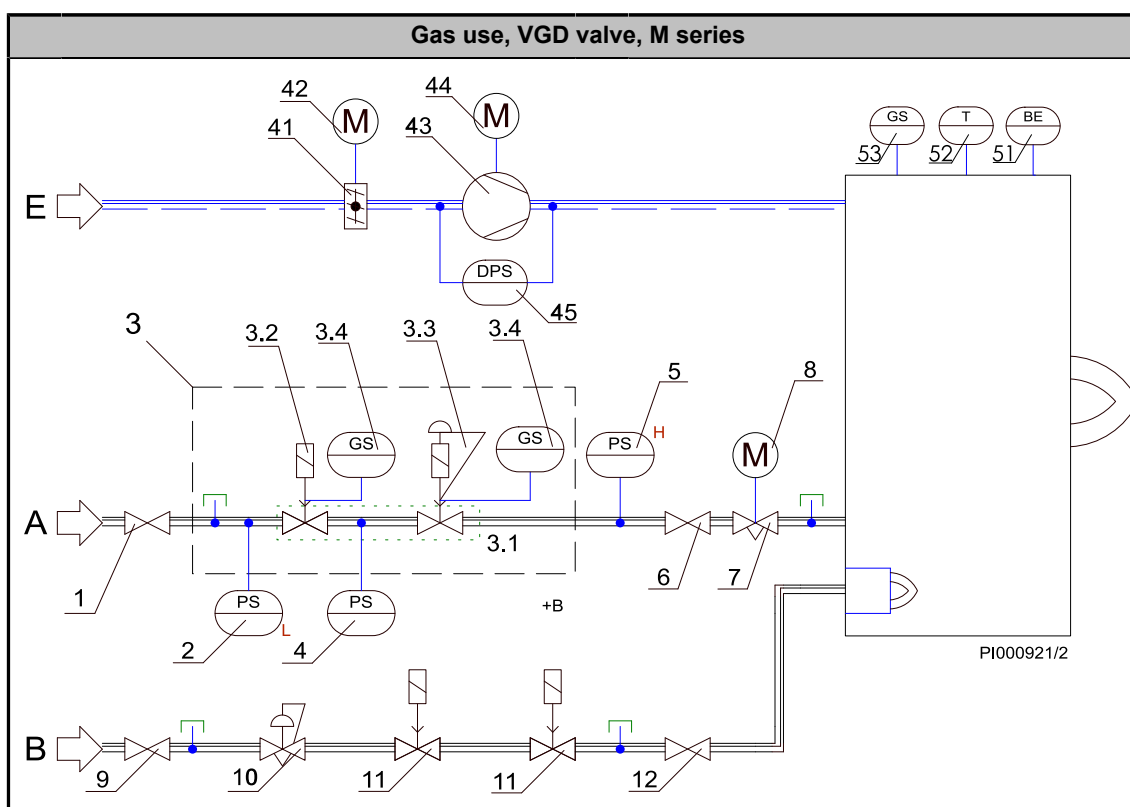

Pos.	Item	Pos.	Item
1	Manual shut-off valve	12	Manual shut-off valve
2	Pressure switch, low	41	Air damper
3	Safety shut-off valves 3.1 Valve 3.2 Actuator + 3.4 (optional) 3.3 Actuator with pressure regulator + 3.4 3.4 Proof of closure switch (IRI: 2 pcs, when capacity > 12.5 MBTU/h)	42	Servomotor
		43	Combustion air fan
		44	Electric motor
		45	Differential pressure switch for air
4	Pressure switch (optional, when capacity < 12.5 MBTU/h)	51	Flame detector
5	Pressure switch, high	52	Ignition transformer
6	Manual shut-off valve	53	Burner hatch limit switch
7	Gas butterfly valve	54	Connection box
8	Servomotor		
9	Manual shut-off valve	E	Air inlet
10	Pressure regulator	A	Gas inlet
11	Safety shut-off valve	B	Ignition gas inlet

5.5 Legend to time sequence diagrams

Phases:

00	Lockout phase	50	2nd safety time
01	Safety phase	52	Interval 2 (ti2)
10	Homerun	54	Low-fire position
12	Standby (stationary)	60	Operation 1 (stationary)
21	Shutoff valve ON (start release)	62	Operation 2 Low-fire position
22	Fan motor ON	70	Post-combustion time
24	Pre-purge position	72	Post-purge position
30	Pre-purge time (tv1)	74	Post-purge time (tn1)
32	Pre-purge time (tv)	76	Flue gas recirculation post-purge position
34	Pre-purge time (tv2) (flue gas recirculation ARF)	78	Post-purge time (tn3)
36	Ignition position	79	Direct start
38	Pre-ignition (Z) ON	80	Valve proving evacuating time
40	Burner valve ON	81	Valve proving time atmospheric pressure
42	Ignition OFF	82	Valve proving filling time
44	Interval 1 (ti1)	83	Valve proving time gas pressure

Times:

t0	Post-purge lockout position	t78	Post-purge time 3 gas / oil (tn3)
t01	Max. time safety phase	t80	Valve proving evacuate time
t10	Min. time home run	t81	Valve proving time atmospheric pressure
t21	Min. time start release	t82	Valve proving filling time
t22	Fan running time	t83	Valve proving time gas pressure
t30	Pre-purge time part 1	tmn1	Min. time extraneous light test (5 s) after skipping pre-purge
t34	Pre-purge time part 3	tmx1	Max. damper running time
t36	Min. ON time oil pump	tmx2	Max. time startup release
t38	Pre-ignition time gas/oil	tmx3	Max. time circulation heavy oil
t42	Pre-ignition time OFF	tn	Post-purge time
t44	Interval 1 gas/oil	TSA1	First safety time gas/oil
t62	Max. time low-fire	TSA2	Second safety time gas/oil
t70	Post-combustion time	tv	Pre-purge time gas/oil
t74	Post-purge time 1 gas / oil (tn1)		

Abbreviations:

AL	Alarm	PV	Pilot valve
ARF	FGR = flue gas recirculation	R	Temperature or pressure controller ON (internal + external)
CPI	Closed Position Indicator	RP	No-load position
DP	Pressure switch	SK	Safety loop (safety limit thermostat, water shortage)
DW-DK	Pressure switch + valve proving	SP	Setpoint position
DWmin	Pressure switch-min	SR	Safety relay internal
DWmax	Pressure switch-max	STB	Safety limit thermostat
FS	Flame signal	SV	Shutoff valve

GSK	Fan contactor contact	TW	Temperature switch internal
KL	Low-fire position	V1	Fuel valve 1
LK	Air damper	V2	Fuel valve 2
LP	Air pressure switch	V3	Fuel valve 3
M	Fan motor	VL	Pre-purge position
N	Post-purge	Z	Ignition
NL	Post-purge position	ZL	Ignition load position

Symbols:

Signal ON	Signal OFF	Next phase
		01 00, repetition = 0 12, repetition > 0
		Parameter <i>NormalDirectstart</i> Checking with controller ON Deviation → 10 No repetition decrement
		10
		70
		Without valve proving → 70 With valve proving → 80
		62
		Stop, up to phase maximum time → 01
 0...3 s		Stop, up to phase maximum time → 10
 0...3 s	 0...30 s	01 00, repetition = 0 12, repetition > 0

	Output OFF / input Irrelevant
	Output ON / input ON

	Permissible positioning range
	In Standby: actuator can move within the permissible positioning range, but is always driven to the home position. It has to be in the home position before changing the phase.

0°	Position as supplied (0°)
90°	Actuator fully open (90°)

Indices:

1)	Param.: <i>ValveProvingType</i> → Valve proving takes place between phases 30/32 and/or phases 60/70
2)	Param.: Short / long pre-ignition time for oil only Short / long oil pump – ON – time
3)	Delayed shutdown within safety time
5)	Param.: Normal / direct startup Normal startup → sequential phase = 10 Direct startup → sequential phase = 79 (when R = ON)

6)		Sequential phase = 24
7)		Only with valve proving during startup
8)	Param.:	With/without alarm on prevention of startup
9)	Param.:	With continuous purge the shown output signals are inverted
10)		Fan controlled as before Post-purge in lockout position = <i>PostpurgeLockout</i>
11)	Param.:	With / without extraneous light test in STANDBY
12)		With valve proving during startup phase 10
13)	Param.:	Normal / continuous purge Normal purge: Checking for OFF in 10 and 12, stop to phase-max time → 01 Continuous purge: Checking for ON in 10 and 12, stop up to phase-max time → 01
14)	Param.:	<i>OilPressureMin, act from ts</i> → no check before first safety time (LO, HO) or second safety time (LOgp, HOgp)
15)	Param.:	<i>GasPressureMin, deact xOGP</i> → pressure switch-min (Pmin) can be deactivated for oil programs with gas pilot
16)	Param.:	<i>OilPumpCoupling:</i> <i>direct_coupl</i> → shutoff valve - oil to be connected to output <i>Oil pump / magnetic clutch</i> . Output is active when fan is on and for another 15 s after fan is switched off.
18)	Param.:	<i>Alarm act / deact, deactivated</i> → alarm output can temporarily be deactivated (for current error only)
19)	Param.:	Only LMV50... and LMV52...: Continuous pilot gas/oil: Activated → pilot valve is also activated in operation
20)	Param.:	Only LMV50... and LMV52...: Extraneous light, pilot phase, operating phase gas/oil → Separate flame supervision possible
22)	Param.:	Depending on parameter <i>StartPoint Op</i>
23)	Param.:	Depending on parameter <i>DriveLowfire Gas</i> or <i>DriveLowfire Oil</i>
24)	Param.:	Depending on parameter <i>HeavyOilDirStart</i>
25)	Param.:	Air pressure test = deactivated in standby → irrelevant in phase 10 and 12
26)	Param.:	Long post-purge time <i>tn3 (PostpurgeT3long)</i>
27)	Param.:	Only LMV50... → cooling function in standby
28)	Param.:	Continuous purge

k)	Heavy oil direct start
l)	Restricted startup behavior
n)	Restricted safety loop

5.6 Time sequence diagram, gas use

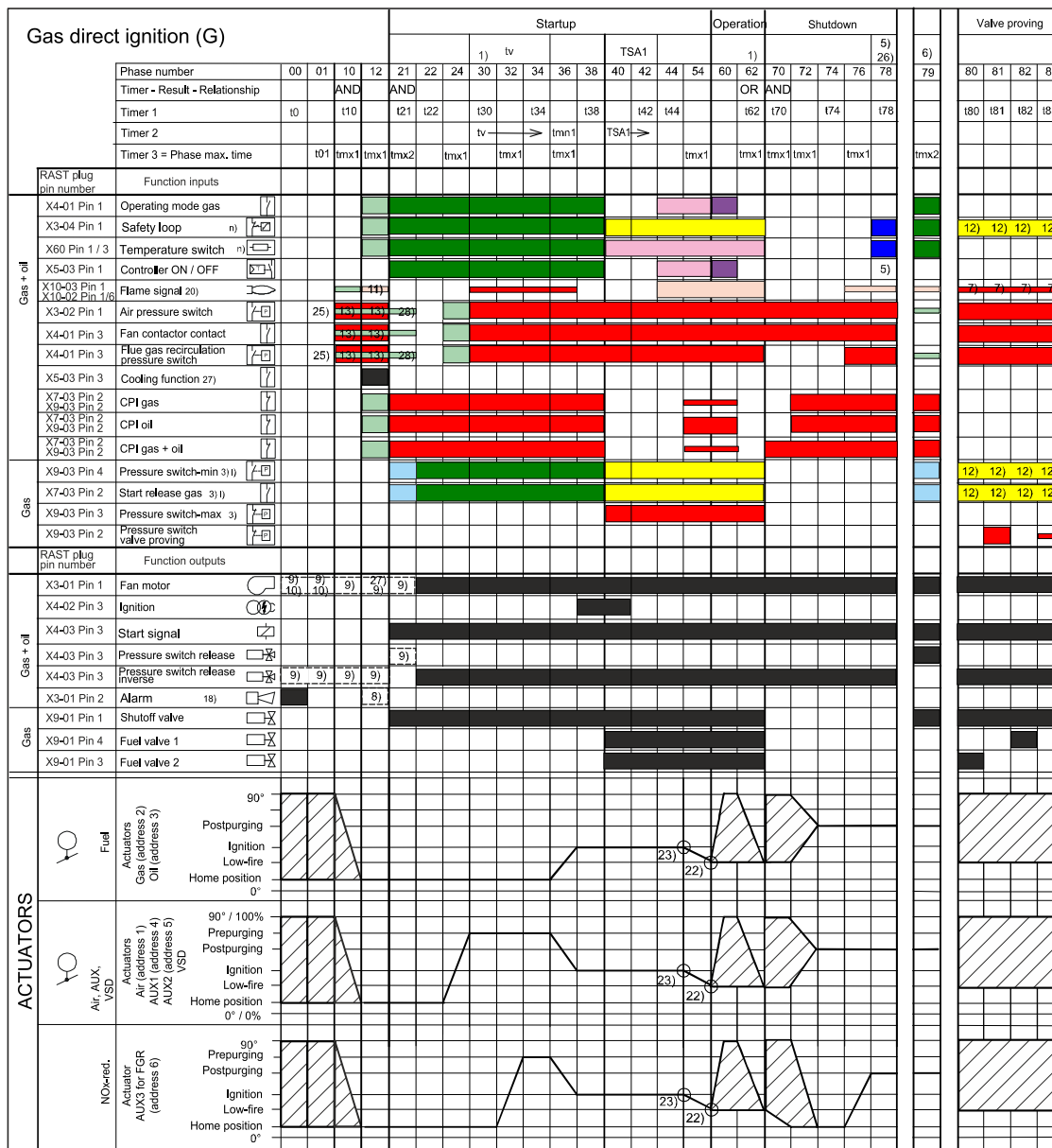

7550f64e/0515, G ver. 4

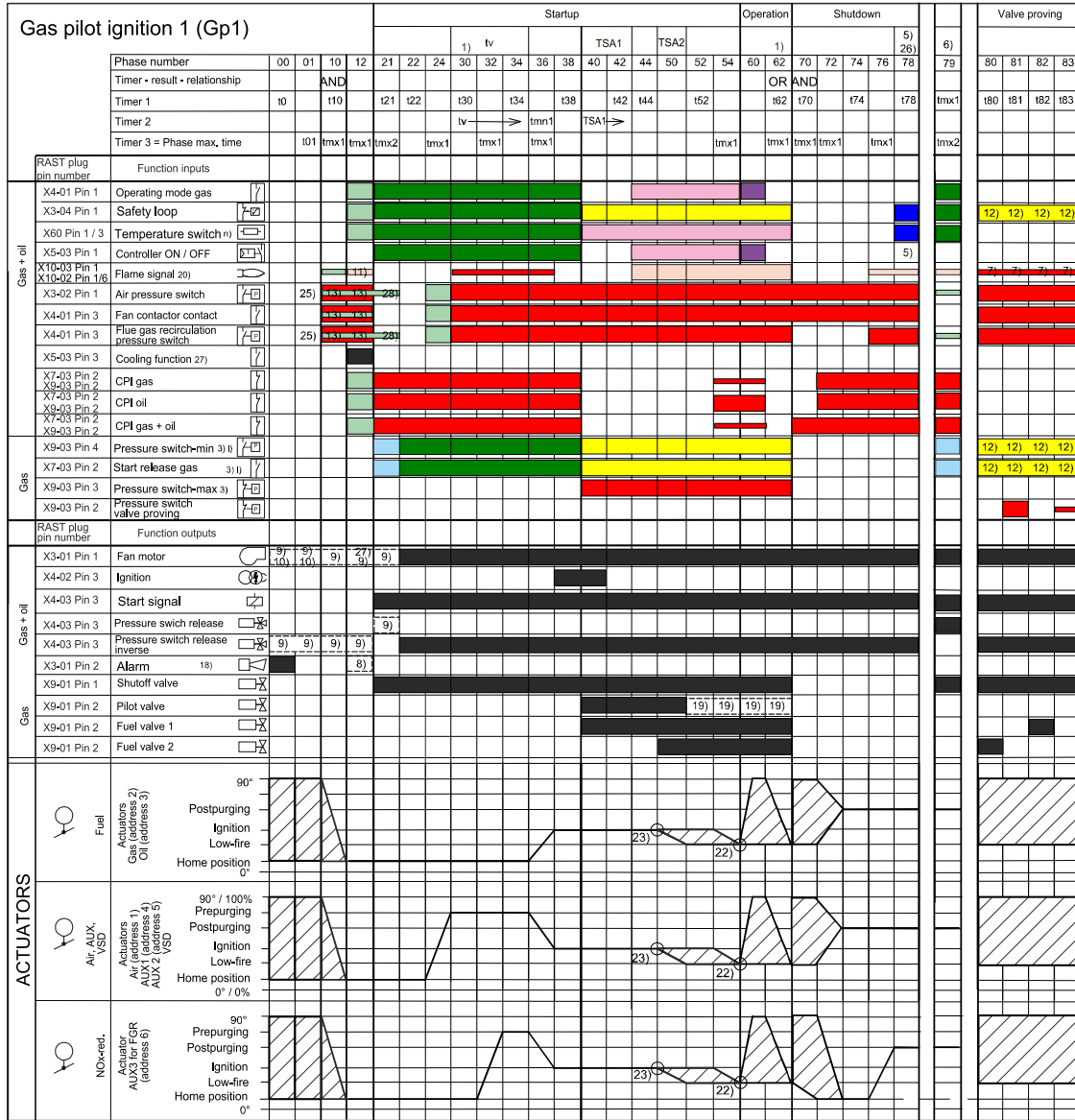

7550f57e/0515, Gp1 ver. 6

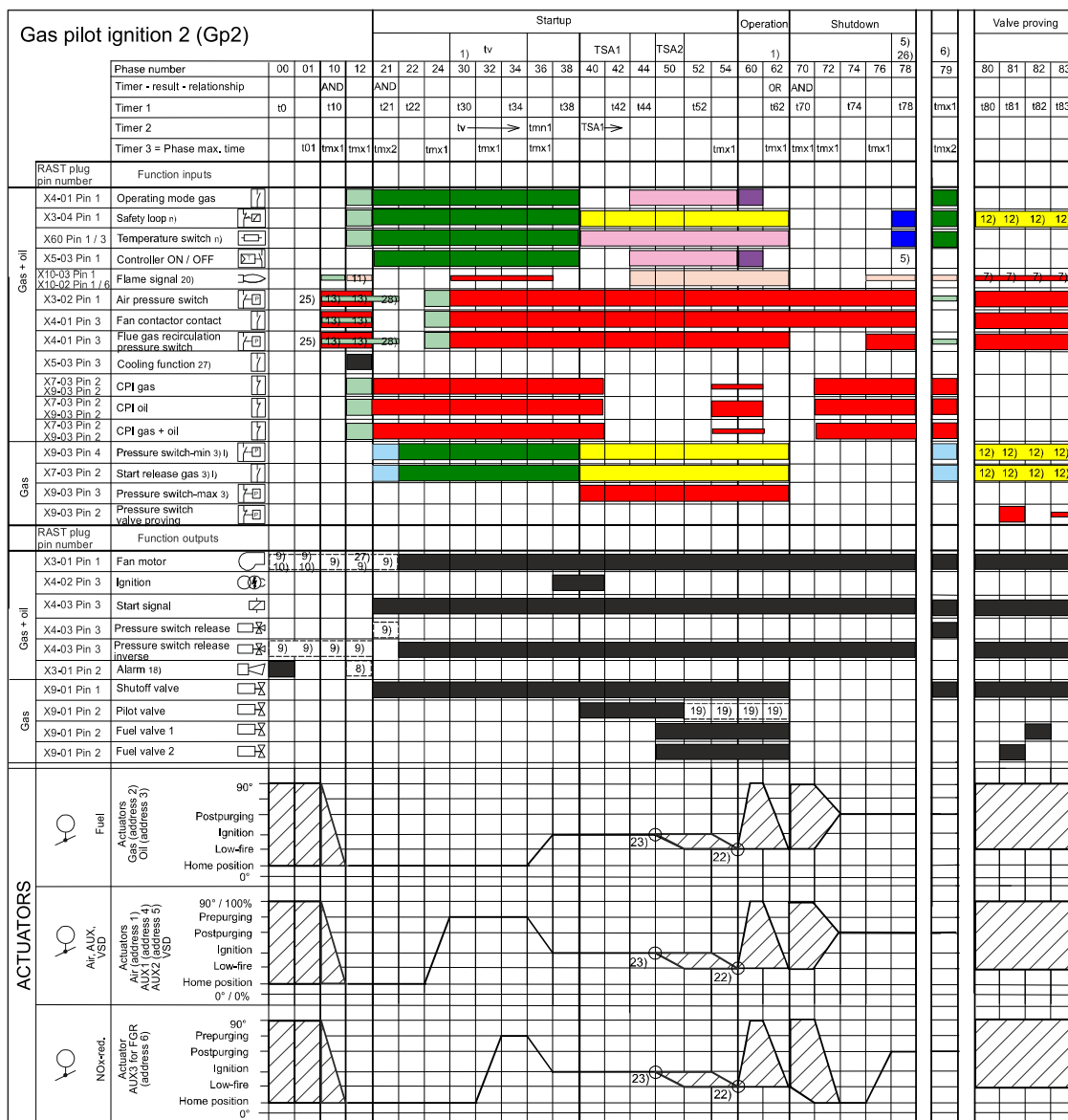

7550f60e/0515, Gp2 ver. 2

5.7 Burner automation description, gas use



Items marked with an asterisk (*) apply only if the burner is equipped with an ignition gas valve.

Prerequisites for start

- All failures and interlocks reset.
- Burner flange limit switch closed.
- Safety loop closed.
- Boiler safety devices not activated.
- Control switch in position 1.
- Burner control in stand-by position.
- Manual or automatic mode selected in burner control. If automatic mode is selected, the capacity controller must also be switched on.

- Remote control contacts closed.
- Boiler thermostat/pressure switch contact closed.
- Differential air pressure switch contact open.

20, 21 Start-up

- Burner control safety functions are activated.
- Gas safety valve (optional) opens.
- Gas pressure recognition, pressure switch min. closed.
- Gas start release circuit (optional) closed.

22 Fan motor starts

24 Servomotors drive to pre-purge position

- Fan contactor must be closed or driven by a variable speed drive. Motor sensor must detect the motor's rotation speed and direction.
- When a sufficient air pressure is reached, the differential air pressure switch contact closes. Otherwise, burner control goes to a lockout. Control remains active until controlled shutdown.

30...34 Pre-purge

- Pre-purge begins.
- If the previous shutdown was not normal or the burner has been switched off, an automatic gas valve proving is performed.
- If burner control receives a flame signal, burner control goes to a lockout. Control remains active until the beginning of pre-ignition.

36 Servomotors drive to ignition position.

38 Pre-ignition begins.

40... 42 First safety time TSA1, max. 10 s, begins.

- Ignition gas valve opens.*
- Gas valve 1 opens.
- Ignition gas is released to ignition nozzle.*
- An electric arc is formed. An ignition flame* is ignited by the arc.
- Gas maximum pressure control period begins. Pressure switch max. contact must be closed, otherwise burner control goes to a lockout.

44 Interval 1, safety time TSA1, max. 10 s, ends

- First safety time, max. 10 s, ends.
- Ignition ends.
- Flame (ignition flame*) must have been ignited by now. Otherwise, burner control does not receive a flame signal and goes to a lockout.
- Flame signal must be available to burner control from the end of the 1st safety time until controlled shutdown.
- Flame burns at a set ignition load.

50* Second safety time TSA2, max. 10 s, begins

- Gas valve 2 opens.*
- Gas flows through a gas butterfly valve to the nozzle.*
- Main flame is ignited by the ignition flame.*

52* Interval 2, second safety time ends.

- Ignition gas valve closes.*
- The main flame must have been ignited by now. Otherwise, burner control does not receive a flame signal and goes to a lockout.*
- Main flame burns at a set ignition load.*

54 Servomotors run to min. capacity

60 Operation

- Burner control in automatic operation: the burner's capacity controller adjusts burner capacity within its modulating range to correspond to the current load by controlling air dampers, gas regulator and fan motor rotation speed. The burner operates controlled by burner control and capacity controller according to set parameters and functions. If a process value exceeds the corresponding controller setting, the burner is switched off.
- Burner in manual operation: the burner runs at a capacity set by the user. A boiler thermostat or pressure switch controls when the burner is switched off.
- Lockout, if flame signal or air pressure signal is lost during operation.
- Lockout, if gas pressure rises too high.
- Lockout, if servomotors do not reach the defined position during operation.
- Lockout, if fan contactor contact opens or fan motor rotation speed signal disappears during burner operation.
- Lockout, if the user presses the operating and display unit's **Esc** and **Enter** button simultaneously during operation.
- Immediate shutdown, if gas pressure drops too low during operation.
- Immediate shutdown, if start release circuit opens during operation.
- Immediate shutdown, if safety loop opens during operation.
- Immediate shutdown, if boiler temperature limiter is activated during operation.

62 Controlled shutdown

- Servomotors run to min. load.
- Burner control carries out automatic gas valve proving.

70 Post-purge begins

- Gas safety valve closes (optional).
- Gas valve 1 closes.
- Gas valve 2 closes.

72... 78 Post-purge begins

- Servomotors run to post-purge position.
- Lockout, if burner control receives flame signal.
- Fan motor stops at the end of phase.
- Burner control safety functions end at the end of phase.

10 Servomotors run to stand-by position

- Re-start possible, when standby position 12 is reached.

80... 83 Gas valve proving

- 80: emptying of piping between valves, gas valve 1 closed and valve 2 open.
- 81: test of normal pressure in piping between valves, gas valves 1 and 2 closed.
- 82: filling of piping between valves, gas valve 1 open and valve 2 closed.
- 83: pressure test of piping between valves, gas valves 1 and 2 closed.

00 Lockout phase

- Servomotors run to stand-by position.
- Burner failure activates.
- Requires manual reset.

5.8 Gas valve proving

The system performs gas valve proving using a pressure switch or transmitter that monitors the section of pipe between the valves. During gas valve proving, burner control opens and closes gas valves at programmed intervals. If a leak is detected, the gas valve proving function prevents gas valves from opening and the ignition phase from starting. Safety shutdown is activated. The control unit display indicates which valve is leaking.

Gas valve proving is carried out during a normal burner shutdown, between phases 62 and 70. If the previous shutdown was not normal, for example, because of a lockout or because burner control has been de-energized, it will take place during the next start-up sequence (during the pre-purge period) between phases 30 and 32.

Valve proving sequence phases are 80... 83.

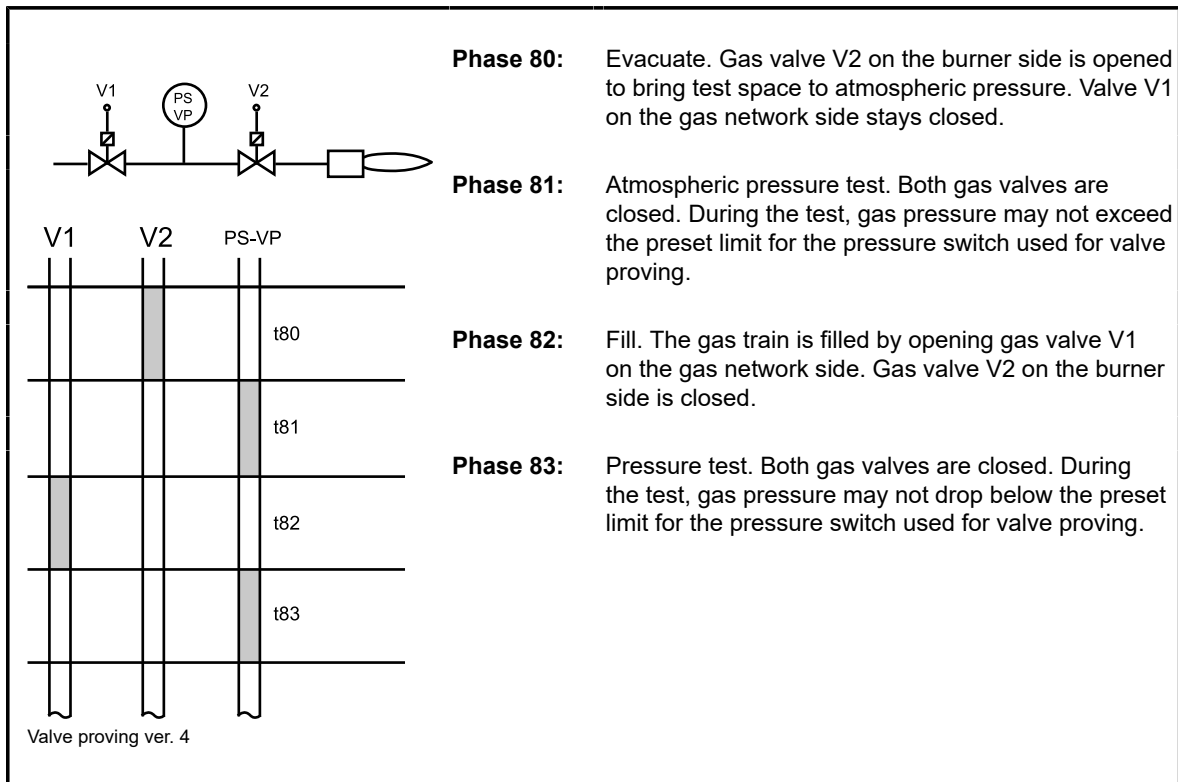

6 Maintenance

6.1 Burner maintenance



Installation, commissioning, or service of the appliance is to be carried out by authorized and trained personnel only, adhering to all local regulations and requirements.



Secure all safety covers, enclosures, and guards with all screws before start-up. Use appropriate tools.



Cut off power supply to the burner and close the manual shut-off valves always before any maintenance work. Cutting power is adequate when just inspecting the device.



Before maintenance, make sure that there is no pressure in the piping. If required, discharge the pressure.



Check the combustion opening regularly for fouling even during periods when the burner is out of use. A blockage in the combustion head may cause a hazard.



If you need help with maintenance issues, contact your nearest representative or visit the Oilon website (<https://oilon.com>) for technical support.



The burner contains electric and electronic components. Adhere to rules and regulations from local authorities when disposing. See section *Handling and storing*.

Before maintenance

- Cut off power supply.
- Close fuel valves.
- Discharge pressure from piping.
- Disconnect ignition cables.
- Remove rods for adjustable combustion head.

To maintain flawless operation, do the following at least once a year:

1. Check burner head extension, and change if necessary.
2. Check diffuser disc, and change if necessary. Check burner adjustments if diffuser disc appears dirty.
3. Check ignition cable condition from the whole length. Change, if necessary.
4. Clean and check ignition electrodes, and check correct position. Change, if necessary.
5. Check flame detector position, condition and cleanliness.
6. Clean filters at least once a year. Filters may have to be cleaned more often depending on circumstantial conditions.
7. Check air dampers fixing screws and servomotor axle lock. Retighten if necessary.
8. Check hoses and pipes and their joints for leaks. Repair/change, if necessary.
9. Check and lubricate adjustment rod joints if the burner has adjustable combustion head.
10. Clean burner from dust and moisture.
11. Check that the boiler room fresh air inlet is open.
12. Check combustion characteristics with flue gas measurement:
 - at regular intervals or when sooting the boiler
 - at least once a year.

Maintenance recommendations

Correct installation and adjustment as well as regular maintenance ensure trouble-free burner operation.

- Service the burner annually.
- Use only original spare parts.
- When ordering spare parts, give the burner type and serial number indicated on the burner type label or manufacturing card.

Opening the burner

The burner can be swung open from its hinged joint for adjusting the ignition electrodes, changing or cleaning nozzles, and other similar tasks.

To open the burner:

1. Switch off power to the burner from the control switch.
2. Close the gas supply from the gas shut-off valve.
3. Detach the oil hose or hoses. Clean any oil dripping from the oil line with an oil-absorbent wipe or similar.
4. Detach any electrical connections that might get in the way or damaged.
5. Open the hinged flange locking screw.
6. The burner can now be swung open from the hinged joint.
7. When closing the burner, perform the steps in reverse order.

Detaching the burner from the boiler



Follow lifting instructions when lifting the burner.



Before reinstalling the burner to the boiler, check that the insulating material around the combustion head is undamaged. Replace if necessary.

NOTICE

It is not advised to detach the burner unless absolutely necessary.



Check that gas lines are leak-proof before putting the burner back into service.

To detach the burner:

1. Switch off power to the burner from the control switch.
2. Close the gas supply from the gas shut-off valve.
3. Disconnect any external electrical connections and connections that might get in the way or damaged. See the electrical diagrams supplied with the burner.
4. Detach the gas inlet pipe from the burner.
5. Support the burner on a solid platform and detach the burner mounting screws or nuts.
6. Pull the burner out of the boiler.

Attach the burner to the boiler by performing the steps in reverse order.

6.2 Maintenance during shutdown



Installation, commissioning, or service of the appliance is to be carried out by authorized and trained personnel only, adhering to all local regulations and requirements.

NOTICE

- Before performing any work on the burner control system, completely isolate the control system from the mains.
- Check all safety functions before use.

During a longer shutdown, perform a visual check of the unit's overall condition and cleanliness.

Follow these general instructions:

- Check and clean nozzles.
- Check the condition and function of actuators, handles, levers, and other moving components.
- Check piping, valve operation, filters, and gaskets.

Start operation only after a thorough inspection. Before start-up, make sure that the appliance is in good working order.

If you need help with maintenance and service, contact your nearest representative or Oilon customer service.

6.3 Dismounting combustion head

Combustion head components and dismounting (GP)

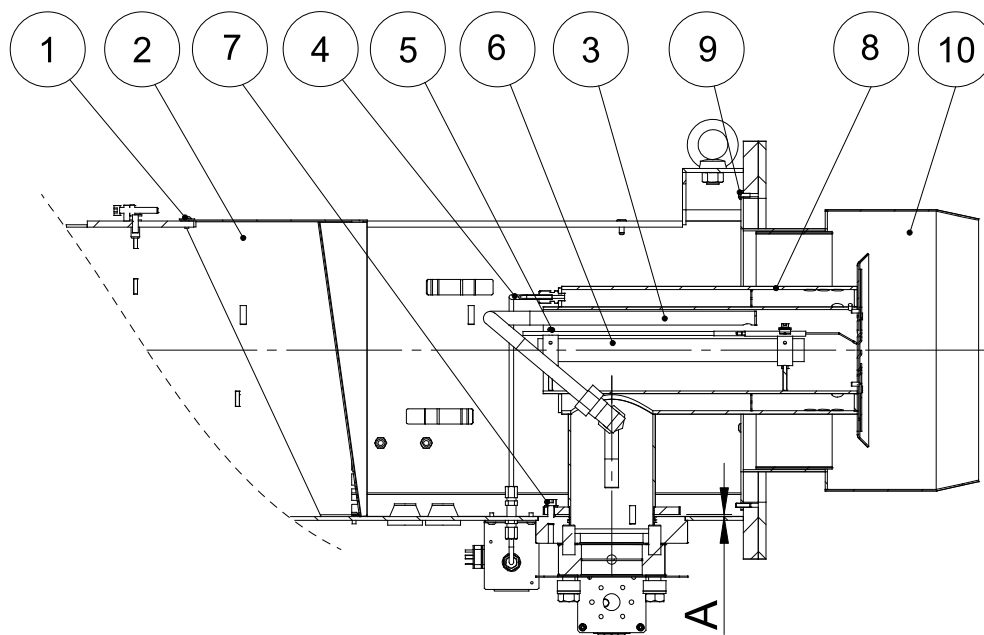

D043819 ver. 2

Disassemble the combustion head components in the same order as in the table, and reassemble in reverse order.

Pos.	Item
1	Air guide fastening screws
2	Air guide
3	Ignition gas nozzle
4	Gas pressure impulse tube
5	Ignition electrode support fastening screw
6	Ignition electrode support
7	Gas nozzle fastening screws
8	Gas nozzle
9	Combustion head fastening screws
10	Combustion head
A	3 ± 3

NOTICE

Check that gas nozzle is centralized in relation to the adjustment ring.



Check the O-ring during assembly. Replace if necessary.

6.4 Dismounting and changing burner motor



Cut off electricity from the burner and ensure that the motor has no voltage.

Fan cross section

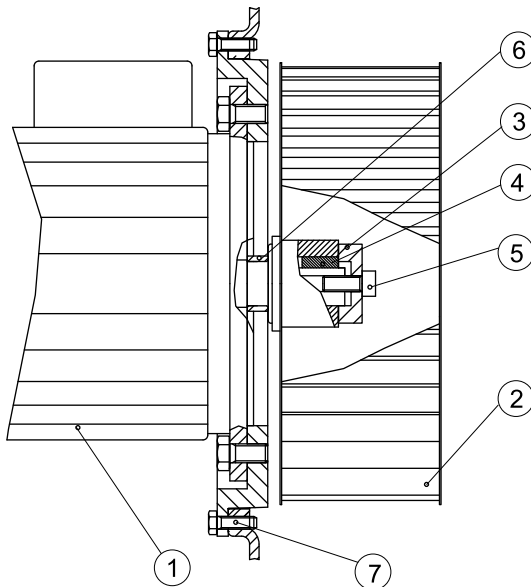

1	Motor
2	Fan wheel
3	Fixing sleeve
4	Wedge
5	Fixing screw of fan wheel
6	Base bushing
7	Fixing screw of mounting flange

A416L ver. 3



If necessary, lift the fan motor with a lifting device or strap.

To dismount motor and fan wheel:

1. Switch off the burner from the mains.
2. Disconnect the electrical cable of the motor.
3. If in use, detach the rotation speed sensor from the motor's fan casing.
4. Screw off screws in the motor mounting flange and lift the motor away.
5. Screw off the fan wheel fixing screw and fixing sleeve.
6. Pull out the fan wheel from motor shaft using an extractor.
7. Loosen the wedge and base bushing.

To mount motor and fan wheel:

1. Place base bushing.
2. Set the wedge into the shaft slot.
3. Pull the fan wheel to its place using a binder plug. The fan wheel lies against base bushing.
4. Place the fixing sleeve.
5. Screw down the fan wheel with a fixing screw to the motor shaft.

6. Place the motor and attach screws.
7. Connect the electrical cable to the motor.
8. Connect the burner to the mains. Check motor rotation direction.

6.5 Assigning servomotors

Addressing servomotor

1. Open servomotor protecting cover fixing screws, and remove cover.
2. Check that terminating resistor is connected as in the original servomotor.
3. Check the state of green signal light. If light is steady, servomotor is unaddressed and is ready for addressing. If light is blinking, servomotor has already been addressed.

Gas servomotor blink cycle example.



1 blink	Air servomotor
2 blinks	Gas servomotor
3 blinks	Oil servomotor
4 blinks	Combustion head servomotor

4. Check address. If address is incorrect, keep red button pressed approx. 10, until green light is steady.

Assigning servomotor bus address

1. Select Params & Display from display and operating unit menu.
2. Select Actuators-> Addressing.
3. Select desired actuator: AirActuator, GasActuator, OilActuator or AuxActuator.

```
1 AirActuator
Start addressing by
pressing ENTER
```

```
1 AirActuator
Press actuator button
```

4. Keep red button pressed until next display appears.
5. Addressing is completed when green light for servomotor address starts to blink according to servomotor addressing number.

```
1 AirActuator
Addressing succeeded
```

6. Place protective cover.

Testing servomotor

Burner control switch is in position 1, control. Choose parameters of initial stage setting from control panel.

Param. & Display					
	RatioControl				
		Fuel settings			
			Special settings		
				Initial stage	
					Initialstage Gas
					Initialstage Air
					Initialstage Aux1
					Initialstage Aux2
					Initialstage Aux3

In standby position run servomotor's axle between 2° - 88°. After maintenance check servomotor's proper function by running servomotor's axle in these positions and return servomotor to initial position.

6.6 Dismounting and changing servomotors



The permissible tightening torque for the elastic coupling clamping screw is 2 Nm. The permissible tightening torque for the tightening screw is 4 Nm.



Once the servomotor has been replaced, test that both the elastic coupling and the servomotor's axle turn freely. Either monitor the components during the next start-up or run the servomotor to its standby position (initial stage).

Servomotor of gas butterfly valve VKF-10

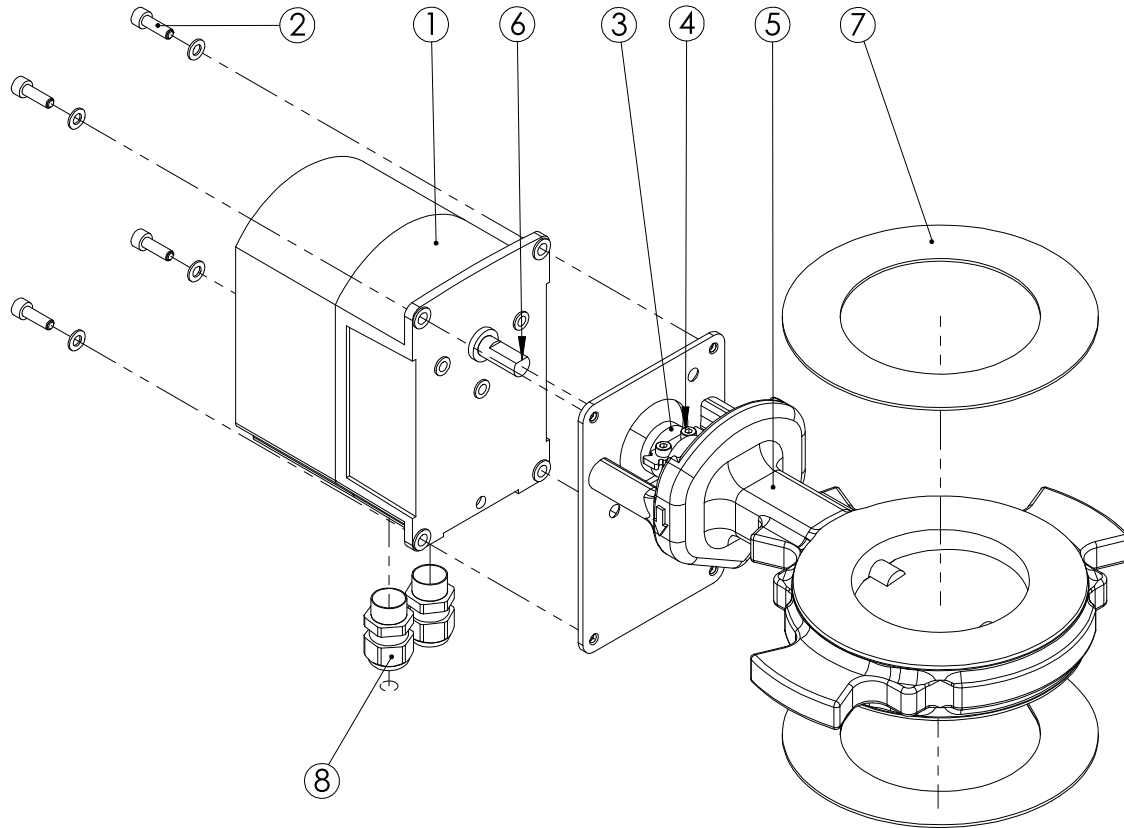

d074074 ver. 1

Pos.	Description	Pos.	Description
1	Servomotor	5	Butterfly valve VKF-10
2	Servomotor fixing screw	6	Aligning surface of servomotor's shaft
3	Shaft coupling	7	Flange gasket
4	Shaft coupling aligning plate and clamping screw	8	Cable fitting

1. Run the servomotor to 90° position so that the clamping screw on the servomotor shaft turns horizontally.
2. Turn off the burner power supply.
3. Disconnect the cables.
4. Loosen the lock and alignment plate of the motor coupling (motor coupling stays on butterfly valve's shaft).
5. Unscrew the servomotor fixing screws and remove the servomotor.
6. Connect the cables to the still loosen servomotor as instructed and turn on the burner power supply.
7. Run servomotor to the 90° position with the burner controller.
8. Turn off the burner power supply.
9. Fasten the new servomotor to the motor coupling.
10. First, make sure that the locking plate of the motor coupling hits the plane of the motor shaft.
11. Tighten the motor coupling locking screw.
12. Tighten the servomotor fixing screws.
13. Connect the power supply to the burner.
14. Run the burner to the original position.

Servomotor of air damper

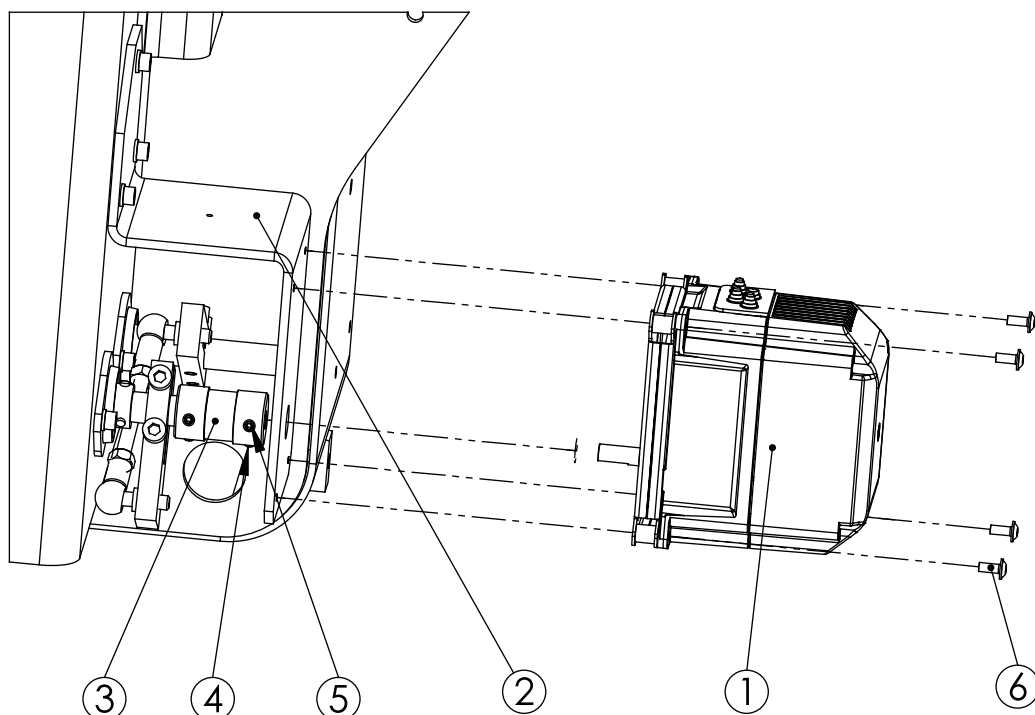

D031517 ver. 1

Pos.	Description	Pos.	Description
1	Servomotor	4	Shaft coupling aligning screw
2	Servomotor bracket	5	Shaft coupling clamping screw
3	Shaft coupling	6	Servomotor fixing screw

1. Turn off the burner power supply.
2. Disconnect the cables.
3. Loosen the shaft coupling clamping screw and aligning screw; shaft coupling is left on air damper axle.
4. Remove the servomotor fixing screws and take out the servomotor.
5. Connect a new servomotor to the shaft coupling.
6. Make sure that the shaft coupling aligning screw is aligned with the servomotor axle plane.
7. Make sure that the clamping screw of the shaft coupling is securely fastened.
8. Mount the new servomotor.
9. Tighten the servomotor fixing screws.
10. Connect the cables according to the instructions.

6.7 Fault and lockout history

Reading fault and lockout history from display menu

The active burner control fault status is shown on the display.

Fault and lockout history can be accessed from the display menu.

OperationalStart	
	FaultHistory
	LockoutHistory

Resetting fault

You can also reset the burner lockout from the control panel. Reset the fault as follows:

1. Press **Esc** until you access the menu level 1.
2. Select **Operational Stat -> Status/Reset**.
3. The fault code display appears on the display. Press **Esc**.

The following text appears:

```

W o u l d   y o u   l i k e
t o   r e s e t   t h e
s y s t e m   w   E N T E R ?
    
```

4. To reset the failure, press **Enter**.
5. To return to the menu level, press **Esc**.

A burner failure can also be reset with a remote reset signal. In models that have a reset button in the control panel, the failure can be reset by pressing the reset button for longer than 1 s.



In models that have a reset button, pressing the button while the burner is running will cause a lockout. Consequently, the button can be used as an emergency stop button.

Fault history stores the last 21 error messages.

Use the **Select +/-** buttons to scroll through the historical data. To switch between code display and clear text, press **Enter**.

Lockout history stores the last 9 burner lockout occurrences. Lockout always causes a shutdown.

Burner manual lockout example

```

3   2 3 . 0 3 . 0 5   1 5 : 4 3
C : A 7       D : 0 9       V : 3 4
S t a r t - N o :   1 2 3 4 5 6
L o a d :         0 . 0       G a s
    
```

- 3. lockout in history
- Occurred 23.03.2005 at 15:43
- C = error code A7
- D = diagnostic code 09
- V = phase 34
- Start-No = start counter reading at the time the fault occurred 123456
- Load = load at the time the fault occurred 0.0%
- Gas = gas as fuel

Burner control can be reset immediately after shutdown. After a reset, the servomotor is driven to its standby position and burner control gives permission for a new burner start-up.



Shutdown means that a failure interlock has been triggered.

O₂ trim activation example for WD200

```

1 2   C l a s s : 0 5   O i l
C o d e : B F   P h a s e : 6 0
D i a g : 0 0   L o d : 6 5 . 4
S t a r t - N o :   1 2 3 4 5 6
    
```

- 12. fault in history
- Class = 05, see the following table
- Oil = Oil as fuel
- Code = BF, error code
- Diag = 00, diagnostic code
- Phase = 60, phase
- Lod = 65.4%, load at the time the fault occurred
- Start-No = start counter reading at the time the fault occurred

Fault class	Description
00	Lockout
01	Safety reset
02	Safe mode
03	Home run
04	Control stop
05	Attention



For more detailed information about fault and lockout codes, refer to Basic Documentation LMV5.



For more detailed information about fault and lockout codes, refer to manufacturer's LMV5 Technical Instructions (LV5-1000).

Remote reset

EN 14459 requirements for remote control must be followed.

The reset device must be able to reset the burner in an appropriate way. Unintended or spontaneous resets from lockout are not allowed.

If the burner can be reset without being within sight of the burner, the following conditions must be met:

- Before reset, the user must be aware of system status.
- The number of successive resets must be limited to 5 or less within 15 minutes. If the number is exceeded, further resets without checking the appliance must be prevented.

6.8 Testing safety and control devices

Perform safety tests for the following components always during burner maintenance or checking. Perform tests at least once a year.

The following components should be tested:

- flame detector
- differential pressure switch
- gas pressure switches
- gas shut-off valves
- servomotors
- O₂/CO trim control (if equipped)
- boiler safety devices

Flame detector

Test method	Outcome
Step 1 1. Prevent any light from reaching the detector and start the burner.	The burner must shut down and lockout at the end of safety time. Error code 25 and the text No flame at end of safety time.
Step 2 1. Start the burner. 2. Activate the flame detector with a light source during pre-purge.	The burner must shut down and lockout at pre-purge program phase. Error code 23 appears on the display.
Step 3 1. Start the burner. Wait until the start-up sequence is finished. 2. Remove the flame detector from the burner, and prevent any light from reaching the detector.	The burner shuts down. Error code 26 and the text Loss of Flame appear on the display.

Differential pressure switch

For the physical location of the ports and for adjusting the switch, see section *Adjusting combustion differential air pressure switch*.

Test method	Outcome
Step 1 1. Disconnect the high pressure hose (+) from the switch. 2. Start the burner. After testing, reconnect the high pressure hose.	Boiler pre-purging begins. The burner must shut down before the pre-purge cycle is completed. Error code 28 and a text Air pressure off appear on the display.
Step 2 1. Disconnect the low pressure hose (-) from the switch. 2. Start the burner. After testing, reconnect the low pressure hose.	Boiler pre-purging begins. The burner must shut down before the pre-purge cycle is completed. Error code 28 and a text Air pressure off appear on the display.
Step 3 1. Start the burner. Wait until the start-up sequence is finished. 2. After the start-up is completed, rotate the setting wheel on the switch towards the maximum setting. After testing, return the setting wheel to its original position.	The burner should shut down before the maximum setting. Error code 28 and text Air pressure off appear on the display.
Step 4 1. Start the burner. Wait until the start-up sequence is finished. 2. After the start-up is completed, disconnect both pressure hoses from the switch. After testing, reconnect both hoses to the original positions.	The burner should shut down immediately after hoses are disconnected. The burner will shut down immediately. Error code 28 and text Air pressure off appear on the display.

Gas pressure switches

For instructions on adjusting the switches, see section *Adjusting gas pressure switches*.

Gas pressure, minimum

Test method	Outcome
Step 1 1. Rotate the setting wheel on the switch to its maximum value. 2. Start the burner. After testing, return the setting wheel to its original position and reset the switch.	Boiler pre-purging begins. The burner must shut down before the pre-purge cycle is completed. Error code 2F and the text Gas Pressure has dropped below minimum Limit appear on the display.
Step 2 1. Start the burner. Wait until the start-up sequence is finished. 2. Rotate the setting wheel on the switch towards the maximum value while the burner is running. After testing, return the setting wheel to its original position and reset the switch.	The burner should shut down before the maximum setting. Error code 2F and the text Gas Pressure has dropped below minimum Limit appear on the display.

Gas pressure, maximum

Test method	Outcome
1. Start the burner. Wait until the start-up sequence is finished. 2. Drive the burner to maximum capacity. 3. Rotate the setting wheel on the switch towards the minimum value while the burner is running. After testing, return the setting wheel to its original position and reset the switch.	The burner will shut down before the minimum setting. Error code 30 and text Gas Pressure has exceeded maximum Limit appear on the display

Gas shut-off valves

If the burner is equipped with an automatic valve proving system the valves are tested to be leak free during each start-up sequence.

To prove the valves manually:

1. Install a pressure gauge between the fuel shut-off valves. Refer to the valve manufacturer's instructions for the exact location of the measuring port.
2. Start the burner. Wait until the start-up sequence is finished.
3. Rotate the dial on the gas minimum pressure switch towards the maximum value. Wait for the burner to shut down.
4. After the burner has shut down observe the reading on the pressure gauge for a few minutes. The indicated pressure must not lower during that time.

Servomotors

During burner start-up the burner control drives the servomotors to maximum position and during shutdown to 0-position. The burner control supervises the correlation of the position settings and back coupling.

During burner shutdown, check the air damper and the locking screws of the fuel adjusting valve. Push air damper plates lightly to make sure they are firmly attached.

O₂ /CO trim control (if equipped)

- The system is self-checking during start-up.
- Confirm proper fuel/air ratio with flue gas analysis.

Variable Speed Module (if equipped)

Test method	Outcome
<ol style="list-style-type: none"> 1. Turn control switch S1 to position 0 (STOP) to cut off power supply from burner control. 2. Detach speed sensor cable from burner controller (connector X70). 3. Turn control switch S1 back to position 1 (CONTROL). 4. To start the burner, turn control switch S1 to the flame position (position 2, AUTOMATIC). 	During prepurge, the burner stops due to a fault. The error code is 15 and the diagnostic code is 40 (VSD Module – Fan speed not reached).

Boiler safety devices

Test method	Outcome
When the burner is in standby position, activate, for example, the temperature limiter switch from the boiler safety chain (X3-04:1) and start the burner. Perform this test to all safety circuit devices one by one. Devices connected to the safety circuit are described in the electrical diagram.	The burner does not start and the text Safety loop open switches with Safety shutdown on the display.

6.9 Troubleshooting



Before troubleshooting, check the section *First start-up*

If the fault can not be found in the *First start-up*, check the individual burner functions. Reset the burner controller if it is in lockout position. The burner goes to standby position. When the prerequisites for start are fulfilled, the burner starts. Observe the burner functions, program phase, and possible faults from the operating and display unit. Use measuring instruments for identifying the fault.

For further information, refer to *Troubleshooting fault codes* or burner control manufacturer manual.

Start failure

Condition	Possible cause	Action
Burner does not start. Burner control remains in stand-by position. Set temperature or pressure too low.	Break in control loop. Required start-up signal from burner control terminal X5-03.4 does not transfer to terminal X5-03.1.	Find out the cause of the break.
	Control unit is damaged.	Change.
Control loop closed, burner or control unit start-up program does not start.	<ol style="list-style-type: none"> 1. Faulty servomotor 2. Faulty control unit 3. Mechanical jam in levers or couplings. 	<ol style="list-style-type: none"> 1. Change servomotor. 2. Change control unit. 3. Check and release.
	Safety loop open.	Find out cause of the break. Check burner control terminals X3-04.1 and X3-04.2
	Faulty differential air pressure switch.	Change.

Condition	Possible cause	Action
Fan motor starts. Lockout during pre-purge.	Jammed or damaged servomotor. Servomotors do not reach desired position.	Check and adjust or change.
Burner control stays waiting for start release.	Start-up release loop is open.	Find out cause, repair.
	Low gas pressure.	Find cause and repair.
	Faulty differential air pressure switch.	Change.

Motor failure

Condition	Possible cause	Action
Fan or oil pump motor does not start. Lockout occurs.	Break in main circuit.	Find out cause of the break.
	Break in control circuit.	Find out cause of the break, see circuit diagram. Check burner control operation. Replace faulty burner control.
	Motor overload/thermal relay released.	Check setting, reset.
	Faulty motor contactor.	Change.
	Faulty motor.	Change.
	Fault in variable speed drive or soft starter (if equipped).	Check error and reset.

Lack of fan air pressure

Condition	Possible cause	Action
Fan motor starts, but during pre-purge period lockout occurs.	Faulty differential air pressure switch setting.	Check setting, adjust if necessary.
	Dirty or damaged differential air pressure switch impulse tubes.	Clean or replace.
	Faulty differential air pressure switch.	Change.
	Fan suction blocked.	Clean.
	Incorrect motor rotation direction.	Reconnect motor.

Leakage test failure

Condition	Possible cause	Action
Leakage test failure	Gas block failure	See section <i>Gas valve proving</i> .
	Gas inlet pressure to burner too low	Find out cause and repair.
	Faulty pressure switch	Change.
	Faulty gas valve	Change.

No electric arc for ignition

Condition	Possible cause	Action
Fan motor starts, control voltage from burner control to ignition transformer is switched on, no electric arc is formed, and after a short time lockout occurs.	Dirty or damaged ignition electrodes.	Clean or change.
	Ignition electrodes too far apart.	Adjust electrodes according to instructions in section <i>Adjusting combustion head</i> .
	Damaged or disconnected ignition cable.	Change.
	Faulty ignition transformer.	Change.

Flame does not form

Condition	Possible cause	Action
Fan motor starts, the electric arc used for ignition is in order. After a short period of time lockout occurs.	Fuel valves do not open or open too slowly:	
	Break in control circuit. Faulty actuator.	Find out cause of the break. Replace faulty part.
	Faulty fuel pressure.	Check components (filter, throttle plug, regulator, pressure switch) and adjust.
	Faulty fuel/air ratio.	Adjust.
	Faulty combustion head adjustment.	Check and adjust.
	Nozzle dirty or blocked.	Clean or change.
	Too low ignition load.	Check.

Burners with ignition pilot gas valve, ignition flame does not form

Condition	Possible cause	Action
Fan motor starts, ignition is in order. After a short time lockout occurs. Gas valve 1 or ignition gas valve(s) do not open or open too slowly.	Incorrect ignition gas valve setting	Adjust ignition gas valve.
	Faulty actuator.	Change faulty part.
	Cable damaged.	Change.
	Break in valve control circuit.	Find out cause of the break.

Lockout occurs after flame establishment

Condition	Possible cause	Action
Flame forms. Lockout occurs.	Gas pressure unstable.	Check and repair.
	Incorrect burner adjustment	Adjust.
When burner runs to full load, flame extinguishes, shutdown occurs and then re-start.	Gas pressure too low because min. gas pressure switch released.	Check operation and regulations.
	Blocked filter	Clean or replace filter.

Flame monitoring fault, lockout

Condition	Possible cause	Action
Lockout during pre-purge.	Faulty flame detector	Change.
	Faulty burner control	Check fault code. Replace.
	Incorrect flame signal because of extraneous light	Block extraneous light.
Flame forms. Lockout during ignition phase or in normal operation.	Incorrect flame detector position	Repair.
	Dirty flame detector	Clean.
	Flame too weak (light)	Check burner adjustments.
	Faulty flame detector	Change.
Lockout in shut-down period.	Faulty burner control	Check fault code. Replace.
	Faulty flame detector	Change.
	Incorrect flame signal because of extraneous light	Block extraneous light.
Gas use: Lockout during shutdown period	Flame does not extinguish: leaking gas valves.	Replace.

Poor combustion

Condition	Possible cause	Action
CO content is too high or smoke number too high.	Pressure drop in combustion head too low.	Adjust pressure drop.
Diffuser disc burned out	Too low combustion air velocity: incorrect adjustment ring position	Adjust, change diffuser disc if necessary.
	Too low partial load	Adjust, change diffuser disc if necessary.
	Incorrect distance between nozzle and diffuser disc	Adjust.

6.10 Troubleshooting error codes



See the complete fault code list in the control unit manufacturer's manual.

Fault codes

Code	Description
1E	Servomotors do not reach pre-purge or ignition position. Faulty servomotor.
2F	Low gas pressure. Flame forms. Lockout and re-start occur.
1F, 2A, 29	Motor failure.
5	Faulty flame detector.
21	Safety loop open.
22	Temperature limiter released.
23	Lockout during pre-purge.
24	Lockout during shutdown.
25	Flame does not form.

Code	Description
26	Fan motor starts, flame forms then lockout occurs. Flame monitoring fault.
27, 28	Faulty differential air pressure switch.
28	Lack of air pressure.
31, 32	Leakage test failure.
34	No oil supply or too low atomizing pressure. Faulty oil pump.
35	Main solenoid valve does not open. Return oil pressure too high.

6.11 Burner parts (GP)

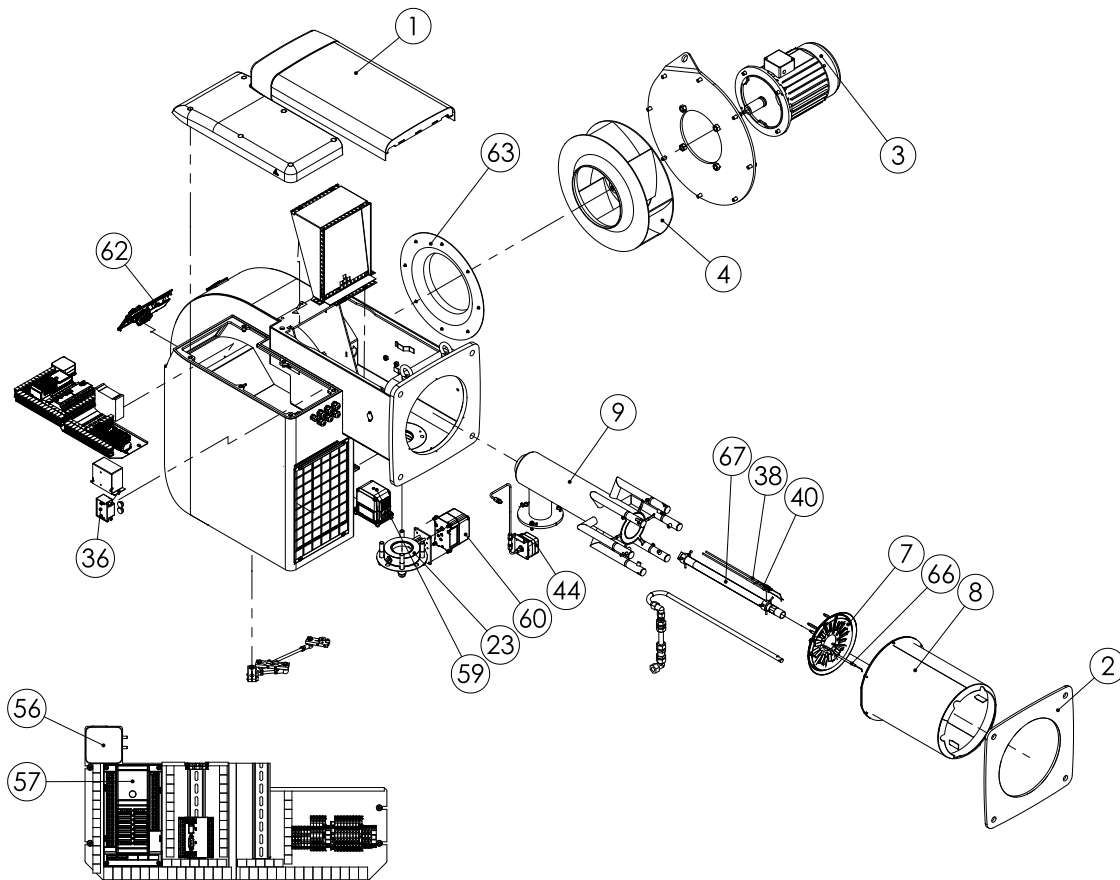

Exploded view GP-350 M - 450 M ver. 3

Pilot gas train

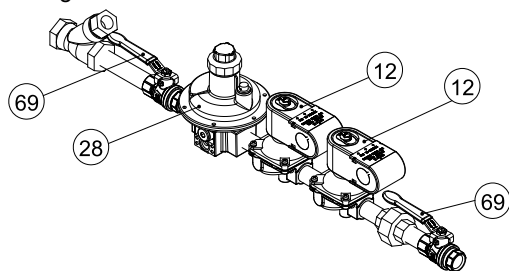

Main gas train

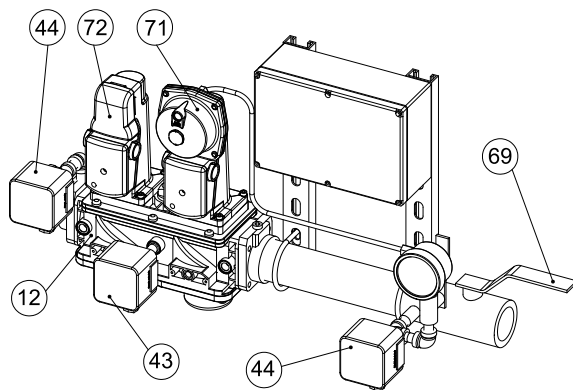

The assembly may vary depending on the scope of delivery.

6.12 Burner part list

#	Part name	Recommended change interval			
		1–2 year	3–5 years	10 years	on demand/ start-up max.
1	Protective cover				X
2	Flange gasket				X
3	Fan motor				X
4	Fan wheel				X
7	Diffuser disc				X
8	Head extension				X
9	Gas nozzle				X
12	Gas valve block			X	250 000
23	Capacity controller			X	
28	Pressure regulator			X	
36	Ignition transformer		X		
38	Ignition cable		X		
40	Ignition electrode		X		
44	Pressure switch, gas			X	
56	Differential air pressure switch			X	
57	Control unit			X	250 000
59	Servomotor, air			X	
60	Servomotor, gas			X	
62	Operating panel				X
63	Air cone				X

#	Part name	Recommended change interval			
		1-2 year	3-5 years	10 years	on demand/ start-up max.
66	Ionization electrode		X		
67	Ignition electrode support			X	250 000
69	Manual shut-off valve				X
71	Valve actuator with pressure regulator		X		
72	Valve actuator		X		

Contact information of Oilon dealer:

Date of installation:

The logo for Oilon, featuring the word "oilon" in a white, lowercase, sans-serif font. A small green leaf-like shape is positioned above the letter 'i'. A registered trademark symbol (®) is located to the upper right of the word.

Oilon US Inc.
P.O.Box 1041
Tel: +1 229 236 6546
info.northamerica@oilon.com
www.oilon.com