

INSTALLATION PROCEDURE

- METHOD FOR INSTALLING FURNACE TILES** - START FROM BOTTOM OF FURNACE AND WORK AROUND BOTH SIDES TO TOP AND DETERMINE IF A CUT TILE IS NEEDED. IF A CUT TILE IS REQUIRED, CUT TO SUIT, SHIFT TILES, AND RE-INSTALL W/ CUT TILE LOCATED ON BOTTOM OF FURNACE.
- METHOD FOR INSTALLING PRECAST DRY OVEN** - GLUE FIBERGLASS ROPE TO DRY OVEN (ITEM #2) AROUND THE OUTSIDE DIA. OF PRECAST (ITEM #1) AS SHOWN BELOW. APPLY TROWLEZE TO END OF FURNACE TILES. FIT UP DRY OVEN AND TIGHTEN IN PLACE. REMOVE EXCESS CEMENT.

ITEM	REQ.	PART NO.	DESCRIPTION	USED ON	OPTION
①	1	459B513	OVEN, DRY - PRECAST	20-25PPM LE STD CB/CBW	A3
1	1	459B526	OVEN, DRY - PRECAST	30-60PPM LE/4WI/CBR CB PROPANE	
②	1	32A107	GASKET - DRY OVEN		A3
3	8	841-513	STUD - MACH.		
4	8	952-108	WASHER - STD. 1/2"		
5	8	869-29	NUT - HEX, BRASS 1/2" - 13		
⑥	1	32A106	GASKET - DRY OVEN		A3
7	8	952-106	WASHER - STD. 3/8"		
8	8	869-37	NUT - HEX. BRASS 3/8" - 16		
⑨	5#	872-390	CEMENT - TROWLEZE H-124	CB/CBW/LE/CBR ONLY	A3
⑩	17	94A203	TILE, FURNACE	CB/CBW/LE/CBR ONLY	A3
⑪	6 FT	872-635	3/4" SQ. FIBERGLASS ROPE		A3

- NOTES:**
- NO CUT TILES TO BE INSTALLED IN UPPER 120° QUADRANT OF FURNACE.
 - PACK ALL TILES TIGHTLY W/ Mallet and REMOVE ALL EXCESS CEMENT - 1/16" TYPICAL JOINT / 1/8" MAX. ONLY APPLIED BETWEEN TILES AND DRY OVEN. ALL TILES SHOULD FIT TIGHT TO FURNACE WALLS W/ NO EXPANSION SPACE BETWEEN.
 - STAGGER ALL CEMENTED JOINTS (SEAMS) BETWEEN ALL TILES.
 - AFTER EACH HALF COURSE OF TILES IS INSTALLED, CLEAN UP EXCESS CEMENT AND FILL IN ANY OPEN JOINT (SEAM) AREAS.

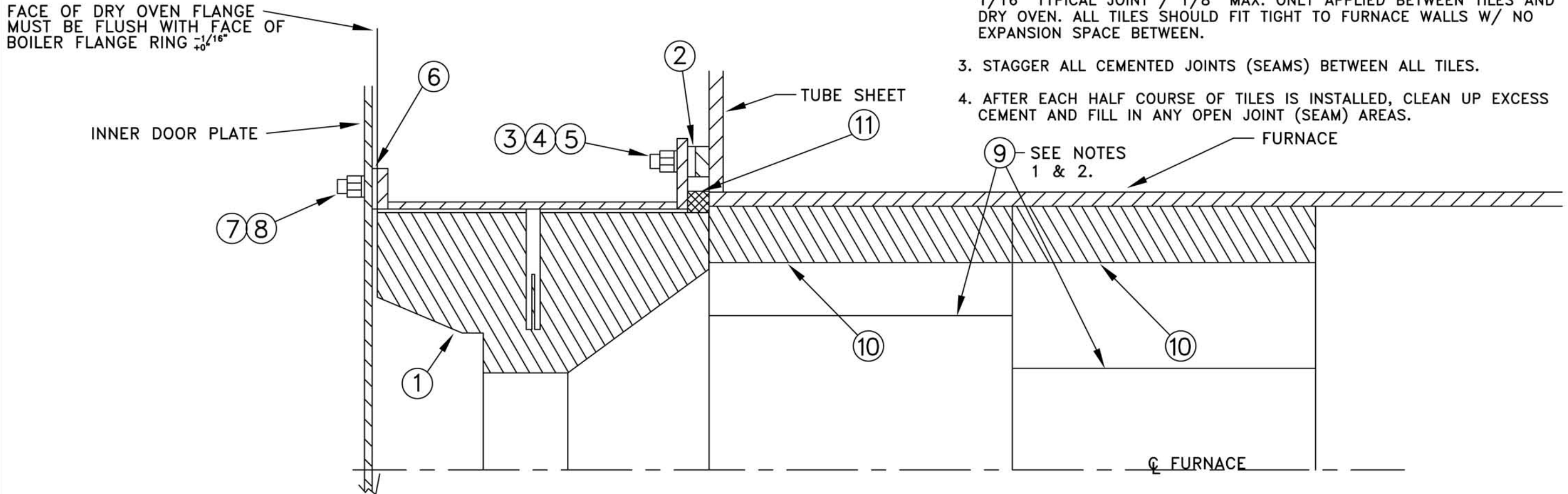

THIS DRAWING IS PROPERTY OF CLEAVER-BROOKS, INC. IT IS SUBJECT TO CHANGE WITHOUT NOTICE, AND IS NOT TO BE COPIED OR USED IN ANY WAY DETRIMENTAL TO THE COMPANY.

REVISIONS	EN# 36815-BB
DATE	01/03/28/96MS
ADD OPTIONS, NEW BORDER	EN 37181-T
ADDED ITEM #1 FOR 30-60PPM LE AND PROPANE CB, EN#37663-NN	02/02/24/00DH
CHANGED P/N FOR ITEM #1 FOR 30-60 PPM LE AND CB W/ PROPANE FROM 459-529, EN#37739-X	03/10/09/00DH
ADDED MODEL 4WI, EN #38172-H	04/11/19/04DH
ADDED MODEL CBR, EN#38788-A	05/2/28/06DH

146 00260	ALL MATERIAL SIZES ON BILL OF MATERIAL ARE FOR REFERENCE ONLY. DRAWING DIMENSIONS MUST BE FOLLOWED. TOLERANCE, UNLESS OTHERWISE SPECIFIED: FRACTIONAL ± DECIMAL ± HOLE LOCATIONS ± ANGLES ± DRILLED, PUNCHED OR SLOTTED HOLES ± .010
SHT 01 OF 01	

SCALE N.T.S.	CLEAVER BROOKS <i>The power of commitment.™</i>
DATE 08/23/95	
DRAWN C A Z	CAST OVEN & FURNACE LINER 60" DIA ,CB,CBLE,CBW,4WI,CBR
SIZE B	DRWG. NO. 146 00260
	05